

MEMORIA TÉCNICA DEL PROYECTO INDICADOR SINTÉTICO DE RIESGO PSICOSOCIAL POR SECTORES Y PAÍSES

FINANCIADO POR EL INSTITUTO ANDALUZ DE
PREVENCIÓN DE RIESGOS LABORALES

CONVOCATORIA 2019

Equipo Investigador:

Jesús Carrillo Castrillo

Luis Onieva Giménez

José Guadix Martín

Contenido

1. Síntesis.....	4
2. Análisis de los valores omisos.....	7
3. Análisis de la normalidad de los valores perdidos	8
4. Outliers y normalidad.....	13
5. Análisis PCA.....	17
6. Análisis de variables nominales y ordinales	24
6.1 Relaciones entre variables nominales - Metodologías y guías	25
6.2 Análisis entre variables nominales y ordinales – Metodologías y guías.....	27
6.3 Análisis entre variables ordinales – Metodología y guías	29
7. Asociaciones intra-grupo entre variables dependientes y variables cualitativas	31
8. Estudios en PLS.....	34
8.1 Análisis de Modelo de Medida (modelo saturado)	35
8.1.1 Análisis de fiabilidad individual, consistencia interna, validez convergente y validez discriminante	36
8.2 Análisis del modelo estimado (multidimensional y modelo estructural).....	43
8.2.1 Hipótesis de pesquisa	50
8.2.2 Análisis del modelo especificado (modelo de medida multidimensional)	53
8.2.3 Análisis del modelo estructural	58
8.3 Determinación de efectos indirectos por mediación	70
8.4 Resumen de las hipótesis verificadas y de las no soportadas.....	72
8.4.1 Interpretación del modelo V01.....	72
8.5 Tabla Resumen	75
8.6 Versión final del modelo estructural V01	78
8.7 Ecuaciones estructurales que representan un modelo.....	80
8.8 Desarrollo del indicador sintético para el modelo V01A.....	81
8.8.1 Creación del índice general – INDEX V01A.....	84
8.8.2 Medida de los efectos negativos e interpretación.....	85

1. Síntesis

El estudio en el cual intervenimos está basado en datos secundarios, provenientes de recogidas concretadas por encuestas ejecutadas en 2015 (EWCS-EACT-ESENER). Con ello, se pretende la construcción de un “indicador sintético” que mida los impactos de los riesgos psicosociales en el trabajador, y compare dichos impactos por países-regiones y sectores de actividad.

Un indicador sintético consiste en la creación de un índice calculado en base a diversas variables independientes que actúan tanto directa como indirectamente sobre una variable dependiente/resultado (compuesto). El indicador en cuestión podrá ser usado para producir indicaciones futuras en función de los valores analizados.

Para calcular dicho índice, en primer lugar efectuamos una revisión de la totalidad de las cuestiones existentes en la encuesta proporcionada junto con el coordinador del proyecto, seleccionando las cuestiones relevantes a considerar para el estudio, así como determinando cuáles de éstas serán usadas a modo de control. Seguidamente, evaluamos las vías más correctas para tratar los valores perdidos de cada una de las muestras de la encuesta, una vez confirmado que el porcentaje de datos omisos de cada variable era inferior al 10%. Para el tratamiento de los valores perdidos fue empleado el programa estadístico SPSS.23, estudiándose igualmente la normalidad de los mismos.

En tercer lugar, fueron estudiados los outliers y la normalidad de los registros. Como intento para mejorar la situación encontrada, fueron testadas las transformaciones de las variables de escala por los tipos Log10, SQR y la Recíproca, ahora bien, al no mejorarse los resultados obtenidos, se continuó el estudio con las variables iniciales.

Una vez estudiados los valores perdidos, outliers y normalidad, se procedió al objetivo final de dichos estudios; la realización de un análisis PCA. La finalidad de dicho análisis consiste en la búsqueda de constructos que agreguen grupos de variables predictivas, identificándose aquellas variables de escala que han de ser consideradas a efectos de modelización. Posteriormente, llevamos a cabo un análisis de las variables nominales y ordinales y de las relaciones existentes entre las mismas. Más tarde, pasamos a estudiar las potenciales asociaciones intra-grupo entre variables dependientes (escala) e independientes (nominales y ordinales) según cada grupo teórico identificado.

Concluidos los estudios comentados, dimos paso al análisis mediante el programa SmartPLS 3 versión 3.2.9 professional (Ringle, Christian M., Wende, Sven, y Becker, Jan-Michael, 2015. Bönningstedt: SmartPLS GmbH, <http://www.smartpls.com>), con el objetivo de estudiar el modelo pretendido. En primer lugar, creamos un modelo de medida a efectos de comprobar que los conceptos teóricos están medidos correctamente a través de las variables observadas, es decir, si existe equilibrio suficiente en términos de especificaciones y conexiones, de manera que el modelo propuesto exponga correctamente la información contenida por los datos. Para ello, analizamos la fiabilidad individual de los ítems, la consistencia interna y la validez

convergente y discriminante, análisis que nos permitieron presentar el modelo estimado (modelo de medida y modelo estructural). Tras ello, presentamos el modelo teórico, así como las hipótesis que éste conlleva y dando como resultado 31 hipótesis; 20 relaciones causales sin signo, 1 relación causal con signo y 10 hipótesis de mediación.

Seguidamente, procedimos al análisis del modelo de medida multidimensional, para el cual fue creada una nueva base de datos, a través de los datos anteriores y de los scores de todos los constructos, base de datos que permite tratar la multidimensionalidad en el modelo final a través de: la validez externa o convergente, la valoración de la multicolinealidad, la valoración de la relevancia de los pesos, y la valoración de la significación de los pesos, ésta última a través de un Bootstrapping de 5000 remuestreos, con test de 2 colas y un $p_{value} < 0,05$. Una vez confirmada la fiabilidad y validez de las medidas de los constructos, llevamos a cabo el análisis del modelo estructural, valorando los resultados de dicho modelo examinando su capacidad predictiva y las relaciones entre los constructos, para ello llevamos a cabo 6 pasos: (1) valorar la colinealidad del modelo estructural, (2) valorar la significación y relevancia de las relaciones del modelo estructural, (3) valorar el nivel de R^2 , (4) valorar el tamaño de los efectos f^2 , (5) valorar la relevancia predictiva general Q^2 y relevancia predictiva de modelo a nivel de variable manifiestas (MV) por vía del PLS-Predict, y (6) presentar la Bondad del Ajuste del modelo a través del índice – SRMR.

A continuación, llevamos a cabo una revisión del modelo en cuanto a efectos indirectos por mediación de la variable 11_Positive_Outcomes, mediante la determinación de la significación de los efectos indirectos ($a_i \times b$) y del tipo de efecto y su magnitud (VAF, Variance accounted for), presentando un resumen de las hipótesis verificadas y no soportadas, y una Tabla Resumen que recoge información en cuanto al valor y significancia de relaciones entre constructos que puedan explicar la variable endógena final, en vistas a ayudarnos en la toma de decisiones para el mantenimiento o supresión de regresiones del modelo estructural. De estos tres análisis, concluimos que el constructo 09_ChiefRelations_13G-WkRelations es candidato a la supresión, pues no presenta significancia en sus caminos, y no produce efectos directos ni indirectos en ninguna de las dos variables endógenas, pero del test de Bootstrap descubrimos que dicho constructo tiene muy fuerte correlación con el constructo 08_Org_relations_12G-Org_Culture en términos causales, por lo que nuestra recomendación sería de evitar su supresión.

En conclusión, ofrecemos tres modelos; uno ya estudiado; una versión rectificada, truncada con supresiones comentadas; y un último modelo con el que descubrir relaciones causales para que su ajuste quede equivalente entre el modelo saturado y el modelo especificado. En el modelo rectificado (EWCS-general_structural_model-evo3supression_based-V01A), se eliminó el constructo 09_ChiefRelations_13G-WkRelations y las regresiones cuyo efecto es nulo y que no producen efectos de mediación. De los tres, el modelo que sirvió para formular el indicador sintético fue la versión V01A, que es aquella elegida por los solicitantes del trabajo.

En cuanto a las ecuaciones estructurales para representar el modelo, hemos tenido en cuenta tanto efectos directos en la variable endógena, como sus indicadores y efectos indirectos por mediación, así como el modo reflectivo o formativo de los constructos exógenos. Para poder interpretar valores obtenidos a partir de la ecuación que mide los efectos totales en la variable endógena final, desarrollamos un índice general (INDEX V01A), el cual proporciona un intervalo $[0,100;1,000]$, en el que se encuadrará el resultado de cada país o región después de la conversión iterativa de la medida obtenida, correspondiendo el máximo valor a mayores influencias en las condiciones negativas. En cuanto a la valoración de la medida general obtenida en términos del índice, se aplica el LIM – Linear Iteration Method, siendo Y el valor a determinar para efectos de índice, y X el valor obtenido por aplicación de las ecuaciones estructurales. Por último, el valor medio obtenido del cálculo de los efectos producidos en el modelo es de -1,52144118, cuya conversión corresponde a 0,362 para el índice, por tanto, el efecto agregado de los 35 países participantes se encuentra por debajo del punto neutro (0,45), de lo que se deduce que las condiciones generales benefician superlativamente respecto a impactos positivos, superando éstos los efectos negativos.

Informamos de los pasos seguidos en la progresión del trabajo:

- 1) Eliminación de variables cuya función era únicamente identificar los casos válidos para el estudio; Q2c y Q7;
- 2) Análisis en términos de estadística descriptiva, con el fin de detectar los casos omisos de cada variable, confirmando así que éstos equivalen a un porcentaje inferior al 10% de cada una de ellas;
- 3) Test Little MCAR (missing completely at random) para detectar si la hipótesis nula de los valores perdidos se verifica (la orden de los valores perdidos es aleatoria) a través de la significancia, la cual deberá no existir. La confirmación de la hipótesis nula ($P\text{value} \geq 0,05$ según autores (e.g., Little, 1998; Sarstedt, Mooi, 2019)) proclama aleatoriedad cuanto a los datos omisos (MCAR). Si la hipótesis nula es rechazada ($P\text{value} < 0,05$), significa que no deberá existir aleatoriedad, por lo que sería conveniente probar si los datos son de tipo MAR (missing at random) o MNAR (missing not at random), mediante otro tipo de tests (multiple imputation) antes de eliminar las filas correspondientes a los valores perdidos (listwise deletion). La teoría indica que para valores omisos inferiores al 10% y de tipo de datos MCAR (Eekhout et al., 2014), es conveniente aplicar listwise deletion, como solución recomendada. Si los datos son MAR o MNAR (lo que será detectable a través de *t-test* por pares de variables; una de ellas independiente), se utiliza multiple imputation con $m \geq 5$;
- 4) Análisis de outliers y de normalidad;
- 5) Análisis PCA;
- 6) Análisis de las variables nominales y ordinales;
- 7) Análisis de asociaciones intra-grupos entre variables dependientes (escala) y variables cualitativas (nominales y ordinales);
- 8) Estudios en PLS.

2. Análisis de los valores omisos

En cuanto a las variables nominales y ordinales, se detectó un porcentaje máximo de valores omisos de 5,5% correspondiente a la variable Q71b_dic (Working conditions - workplace - there exists an health and safety delegate on working conditions).

Univariate Statistics			
	N	Missing	
		Count	Percent
Q71b_dic	29207	1711	5,5
Q16b	29598	1320	4,3
Q71a_dic	29615	1303	4,2
Q50d_dic	30072	846	2,7
Q50c_dic	30195	723	2,3
Q71c_dic	30208	710	2,3
Q48b_dic	30364	554	1,8
Q48a_dic	30418	500	1,6
Q20_dic	30428	490	1,6
Q73_dic	30431	487	1,6
Q50e_dic	30434	484	1,6
Q50a_dic	30502	416	1,3
Q50b_dic	30591	327	1,1
Q53a_dic	30618	300	1,0
Q53b_dic	30639	279	,9

Figura 1

Respecto a las variables de escala, el porcentaje máximo corresponde a la variable Q18c_inv con un valor de 0,6% (Work change last 12 months - Impact on work).

Univariate Statistics					
	N	Mean	Std. Deviation	Missing	
				Count	Percent
Q18c_inv	30747	3,23	,602	171	,6
Q30h_inv	30819	2,37	1,551	99	,3
Q18b_inv	30828	3,22	,681	90	,3
Q29i_inv	30830	1,58	1,376	88	,3
Q30g_inv	30831	2,63	1,822	87	,3
Q29g_inv	30833	1,67	1,395	85	,3
Q29e_inv	30834	1,65	1,431	84	,3
Q30a_inv	30836	2,81	1,932	82	,3
Q30e_inv	30840	3,82	2,270	78	,3

Figura 2

Antes de comenzar con el procedimiento de análisis de datos omisos, verificamos el porcentaje de casos con omisiones iguales o superiores al 10%, habiéndose detectado 19 casos con valores de 10% hasta un máximo de 35% que fueran suprimidos, resultando un total de 30918 casos supervivientes.

3. Análisis de la normalidad de los valores perdidos

Con el fin de detectar si el patrón de datos omisos sigue reglas de aleatoriedad o si es sistemáticamente no aleatorio, se aplicó el Little's MCAR test con opción de EM (expectation maximization). Debido a la cantidad de variables y de casos surgieron limitaciones computacionales de ordenador, por lo que hemos decidido introducir la totalidad de las variables categóricas y testar 6 grupos de variables de escala. Este método permitió confirmar todas las variables cuantitativas en cuanto a su tipología de aleatoriedad.

A partir de nuestro análisis se presenta la siguiente tabla como resumen de las comprobaciones realizadas.

Variabes Cat. y Nom.	Variabes de Escala	Little's MCAR test χ^2	
Q2a - Q81c_dic	Q18a_inv - Q18d_inv	0,000	No MCAR
	Q29a_inv - Q29c_inv	0,051	MCAR
	Q29f_inv - Q29i_inv	0,000	No MCAR
	Q30a_inv - Q30d_inv	0,003	No MCAR
	Q30e_inv - Q30f_inv	0,195	MCAR
	Q30g_inv - Q30i_inv	0,766	MCAR

Figura 3

Las variables de escala/cuantitativas que tienen valores omisos, son las de los grupos Q18, Q29 y Q30, siendo necesario realizar más testes, para cada una perteneciente a estos tres conjuntos, cuando se configura como no aleatoria la distribución de omisiones (no MCAR), con el fin de comprobar si dichas omisiones están relacionadas con otra/s variables del conjunto de datos. Respecto a las variables cuyos test a los valores omisos presentan aleatoriedad (MCAR $\chi^2 \geq 0,05$), procedemos a reemplazarlos por la media.

En esta fase comprobamos la significancia estadística a través del Pearson's χ^2 test, tratando de identificar la existencia de correlación entre un conjunto de variables de control consideradas y las variables con datos omisos, anteriormente señaladas. Analizadas las variables nominales y ordinales, concluimos que desde Q2a hasta Q17_cat pueden considerarse como de control, influyendo en la variable final endógena del modelo completo objeto del estudio.

Este test nos permite identificar los rechazos erróneos de la hipótesis nula, la cual es verdadera (error type I). Para ese efecto hemos recodificado las variables con datos omisos como dummies, siguiendo un criterio de categorizar como 1 cuando haya dato omiso y 0 en caso contrario. Estas variables creadas son las que verdaderamente fueron testadas.

Presentamos tablas que resumen los resultados obtenidos.

	Crosstabs analysis - Person's χ^2											
	Q18a_inv_dummy	Q18b_inv_dummy	Q18c_inv_dummy	Q18d_inv_dummy	Q29f_inv_dummy	Q29g_inv_dummy	Q29h_inv_dummy	Q29i_inv_dummy	Q30a_inv_dummy	Q30b_inv_dummy	Q30c_inv_dummy	Q30d_inv_dummy
Q2a	0,848	0,428	0,980	0,540	0,493	0,262	0,065	0,002	0,595	0,449	0,665	0,810
Q2b_cat	0,104	0,340	0,448	0,086	0,723	0,154	0,258	0,297	0,666	0,525	0,513	0,318
Q2d_resumen	0,000	0,000	0,010	0,000	0,948	0,643	0,233	0,044	0,074	0,203	0,599	0,510
Q4ab_resumen	0,797	0,570	0,334	0,292	0,925	0,483	0,215	0,888	0,289	0,232	0,051	0,370
Q11_a	0,000	0,000	0,000	0,000	0,098	0,068	0,922	0,660	0,467	0,767	0,681	0,232
Q11_b	0,004	0,001	0,000	0,000	0,064	0,147	0,819	0,511	0,511	0,551	0,311	0,795
Q11_c	0,000	0,000	0,231	0,000	0,938	0,393	0,982	0,890	0,947	0,011	0,435	0,031
Q11_d	0,009	0,416	0,021	0,196	0,548	0,381	0,537	0,504	0,360	0,032	0,669	0,660
Q14_a	0,047	0,385	0,489	0,284	0,124	0,162	0,037	0,022	0,835	1,000	0,938	0,607
Q14_b	0,139	0,855	0,854	0,193	0,282	0,208	0,110	0,093	0,267	0,762	0,794	0,340
Q14_c	0,250	0,181	0,318	0,867	0,290	0,894	0,085	0,190	0,220	0,866	0,747	0,220
Q14_d	0,878	0,313	0,947	0,414	0,814	0,958	0,858	0,985	0,335	0,554	0,524	0,512
Q15a	0,365	0,801	0,988	0,119	0,413	0,423	0,100	0,692	0,460	0,019	0,002	0,488
Q16b	0,008	0,028	0,304	0,047	0,000	0,053	0,001	0,021	0,364	0,000	0,086	0,279
Q17_cat	0,003	0,009	0,087	0,053	0,797	0,221	0,769	0,257	0,130	0,977	0,409	0,688

Figura 4

La cantidad de resultados significantes en los test Pearson's χ^2 exceden lo esperado, pero vamos a considerar que los datos omisos siguen la condición de no aleatoriedad (MNAR), ya que estábamos identificando errores tipo I (rechazo erróneo de hipótesis nula que es verdadera).

Seguidamente, aplicamos la técnica de Multiple Imputation. El setup utilizado para los Random Number Generators fue el algoritmo de MERSENNE twister, y para la Multiple Imputation hemos mantenido su default en lo general.

Los resultados obtenidos con $m = 5$ imputaciones no difieren sustancialmente de las medias de los datos originales, sí habiendo cierta distinción en el tercer decimal al comparar los coeficientes no estandarizados antes de la imputación y los valores Pooled (síntesis de las 5 imputaciones). Seguimos presentando alguna información sintetizada de este proceso, a partir de un estudio de regresión lineal realizado en el fichero creado con las imputaciones.

Model Summary

Imputation Number	Model	R	R Square	Adjusted R Square	Std. Error of the Estimate
Original data	1	,426 ^a	,181	,181	,542
1	1	,426 ^a	,182	,182	,544
2	1	,426 ^a	,182	,182	,544
3	1	,427 ^a	,182	,182	,544
4	1	,426 ^a	,182	,182	,544
5	1	,427 ^a	,182	,182	,544

a. Predictors: (Constant), Q18d_inv Work change last 12 months - Duties & tasks, Q18b_inv Work change last 12 months - salary, Q18c_inv Work change last 12 months - impact on work

Tabla 1

Como puede observarse, el poder predictivo (R^2) de la variable dependiente estudiada (Q18a_inv) no cambia sustancialmente.

ANOVA^a

Imputation Number	Model		Sum of Squares	df	Mean Square	F	Sig.
Original data	1	Regression	1995,423	3	665,141	2260,395	,000 ^b
		Residual	9016,972	30643	,294		
		Total	11012,395	30646			
1	1	Regression	2029,526	3	676,509	2286,291	,000 ^b
		Residual	9147,387	30914	,296		
		Total	11176,913	30917			
2	1	Regression	2031,674	3	677,225	2289,214	,000 ^b
		Residual	9145,375	30914	,296		
		Total	11177,049	30917			
3	1	Regression	2031,539	3	677,180	2291,527	,000 ^b
		Residual	9135,538	30914	,296		
		Total	11167,077	30917			
4	1	Regression	2029,445	3	676,482	2286,945	,000 ^b
		Residual	9144,405	30914	,296		
		Total	11173,850	30917			
5	1	Regression	2032,335	3	677,445	2291,534	,000 ^b
		Residual	9139,089	30914	,296		
		Total	11171,424	30917			

a. Dependent Variable: Q18a_inv Work change last 12 months - hours

b. Predictors: (Constant), Q18d_inv Work change last 12 months - Duties & tasks, Q18b_inv Work change last 12 months - salary, Q18c_inv Work change last 12 months - impact on work

Tabla II

Coefficients^a

Imputation Number	Model		Unstandardized Coefficients		Standardized Coefficients	t	Sig.	Fraction Missing Info.	Relative Increase Variance	Relative Efficiency
			B	Std. Error	Beta					
Original data	1	(Constant)	1,562	,021		74,794	,000			
		Q18b_inv Work change last 12 months - salary	,188	,005	,213	39,103	,000			
		Q18c_inv Work change last 12 months - impact on work	,028	,006	,028	4,490	,000			
		Q18d_inv Work change last 12 months - Duties & tasks	,264	,005	,305	50,352	,000			
1	1	(Constant)	1,557	,021		74,774	,000			
		Q18b_inv Work change last 12 months - salary	,189	,005	,215	39,555	,000			
		Q18c_inv Work change last 12 months - impact on work	,028	,006	,028	4,533	,000			
		Q18d_inv Work change last 12 months - Duties & tasks	,264	,005	,305	50,466	,000			
2	1	(Constant)	1,557	,021		74,778	,000			
		Q18b_inv Work change last 12 months - salary	,189	,005	,214	39,535	,000			
		Q18c_inv Work change last 12 months - impact on work	,028	,006	,028	4,574	,000			
		Q18d_inv Work change last 12 months - Duties & tasks	,264	,005	,305	50,485	,000			
3	1	(Constant)	1,556	,021		74,768	,000			
		Q18b_inv Work change last 12 months - salary	,189	,005	,215	39,576	,000			
		Q18c_inv Work change last 12 months - impact on work	,029	,006	,029	4,672	,000			
		Q18d_inv Work change last 12 months - Duties & tasks	,264	,005	,304	50,410	,000			
4	1	(Constant)	1,557	,021		74,801	,000			
		Q18b_inv Work change last 12 months - salary	,189	,005	,214	39,465	,000			
		Q18c_inv Work change last 12 months - impact on work	,028	,006	,028	4,564	,000			
		Q18d_inv Work change last 12 months - Duties & tasks	,264	,005	,305	50,503	,000			
5	1	(Constant)	1,556	,021		74,796	,000			
		Q18b_inv Work change last 12 months - salary	,189	,005	,214	39,509	,000			
		Q18c_inv Work change last 12 months - impact on work	,028	,006	,028	4,561	,000			
		Q18d_inv Work change last 12 months - Duties & tasks	,264	,005	,305	50,563	,000			
Pooled	1	(Constant)	1,557	,021		74,749	,000	,001	,001	1,000
		Q18b_inv Work change last 12 months - salary	,189	,005		39,489	,000	,002	,002	1,000
		Q18c_inv Work change last 12 months - impact on work	,028	,006		4,573	,000	,003	,003	,999
		Q18d_inv Work change last 12 months - Duties & tasks	,264	,005		50,405	,000	,003	,003	,999

a. Dependent Variable: Q18a_inv Work change last 12 months - hours

Tabla III

Por fin, del cuadro de los coeficientes se concluyó que los valores no estandarizados (B) de la constante de datos originales, y las constantes de las sucesivas imputaciones y de la Pooled tampoco difieren de forma notoria.

Siguiendo la práctica recomendada en estos casos, cuando los datos son de tipo MNAR y no se logra alcanzar resultados razonablemente diferentes, se elige el proceso Listwise Deletion, por lo que seguimos dicho procedimiento, reconociendo las limitaciones de los datos omisos.

Con todo ello, para las variables desde la Q18a_inv a Q18d_inv, desde Q29f_inv hasta Q29i_inv y desde Q30a_inv hasta Q30d_inv, hemos creado una nueva variable (ejemplo: Q18a_inv_LD) y hemos suprimido en ésta los casos correspondientes a los huecos (Listwise Deletion con eliminación de casos). Así, el total de casos resultantes, pasa de ser 30918 a 30318.

Con este proceso se concluye la eliminación de casos, por lo que decidimos no reenumerarlos.

4. Outliers y normalidad

Una regla básica para analizar outliers determina que cuando éstos no son consecuencia de registros errados y no alcanzan valores significativamente elevados, se mantienen.

Los estudios efectuados empezaron con el análisis de Mahlanobis, para de ahí extraer la significancia (Pvalue) a través del test Cumulative Probability with df degree of freedom of chi-square distribution χ^2 value. Valores con Pvalue inferior a 0,001 son considerados outliers. Para ese efecto fue creada una variable MAH_i, que resulta de la combinación de cada grupo de variables que se pretende estudiar (Q18a_inv hasta Q18d_inv; Q29f_inv hasta Q29i_inv; Q30a_inv hasta Q30d_inv).

Tras este proceso, concluimos por la existencia de 806 registros que se preconfiguran como atípicos, pero son requeridos más exámenes para identificar con más exactitud los outliers dentro de éste grupo.

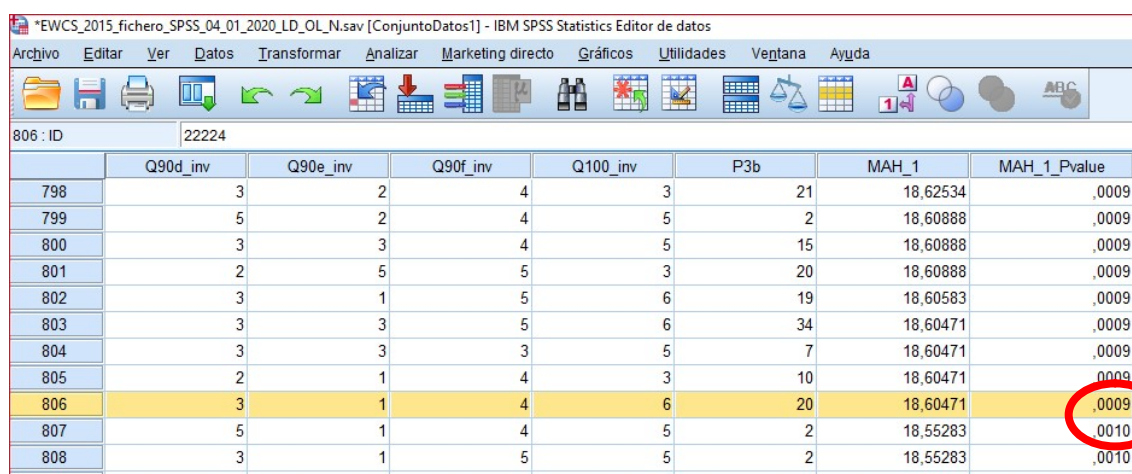

806 : ID	Q90d_inv	Q90e_inv	Q90f_inv	Q100_inv	P3b	MAH_1	MAH_1_Pvalue
798	3	2	4	3	21	18,62534	,0009
799	5	2	4	5	2	18,60888	,0009
800	3	3	4	5	15	18,60888	,0009
801	2	5	5	3	20	18,60888	,0009
802	3	1	5	6	19	18,60583	,0009
803	3	3	5	6	34	18,60471	,0009
804	3	3	3	5	7	18,60471	,0009
805	2	1	4	3	10	18,60471	,0009
806	3	1	4	6	20	18,60471	,0009
807	5	1	4	5	2	18,55283	,0010
808	3	1	5	5	2	18,55283	,0010

Figura 5

Como intento de mejorar la situación de outliers y normalidad, testamos la transformación del grupo de las cuatro primeras variables (Q18), utilizando el algoritmo de computación para transformación, habiéndose testado las transformaciones por medio de Log10, SQR y la Recíproca.

Los resultados obtenidos no tuvieron el éxito pretendido, debido a que aumentaron los valores de medida de la normalidad contenidos en Skewness y Curtosis.

Descriptivos

			Estadístico	Error estándar
Q18a_inv_LD	Media		3,1599	,00344
	95% de intervalo de confianza para la media	Límite inferior	3,1531	
		Límite superior	3,1666	
	Media recortada al 5%		3,1413	
	Mediana		3,0000	
	Varianza		,360	
	Desviación estándar		,59961	
	Mínimo		1,00	
	Máximo		5,00	
	Rango		4,00	
	Rango intercuartil		,00	
	Asimetría		,814	,014
	Curtosis		3,589	,028

Tabla IV

Descriptivos

			Estadístico	Error estándar
Q18a_inv_LD_LOG	Media		,4915	,00050
	95% de intervalo de confianza para la media	Límite inferior	,4906	
		Límite superior	,4925	
	Media recortada al 5%		,4948	
	Mediana		,4771	
	Varianza		,008	
	Desviación estándar		,08696	
	Mínimo		,00	
	Máximo		,70	
	Rango		,70	
	Rango intercuartil		,00	
	Asimetría		-1,442	,014
	Curtosis		10,263	,028

Tabla V

Descriptivos

			Estadístico	Error estándar
Q18a_inv_LD_SQR	Media		1,7696	,00097
	95% de intervalo de confianza para la media	Límite inferior	1,7676	
		Límite superior	1,7715	
	Media recortada al 5%		1,7699	
	Mediana		1,7321	
	Varianza		,029	
	Desviación estándar		,16901	
	Mínimo		1,00	
	Máximo		2,24	
	Rango		1,24	
	Rango intercuartil		,00	
	Asimetría		-,120	,014
	Curtosis		5,174	,028

Tabla VI

Descriptivos

		Estadístico	Error estándar	
Q18a_inv_LD_RECIPR	Media	,3299	,00049	
	95% de intervalo de confianza para la media	Límite inferior	,3289	
		Límite superior	,3308	
	Media recortada al 5%	,3216		
	Mediana	,3333		
	Varianza	,007		
	Desviación estándar	,08597		
	Mínimo	,20		
	Máximo	1,00		
	Rango	,80		
	Rango intercuartil	,00		
	Asimetría	4,984	,014	
Curtosis	36,403	,028		

Tabla VII

Para tomar consciencia de la cantidad de registros que puedan configurarse excesivamente no normales, creamos Z-scores (compuesto de la variable con media cero y desvío padrón de unidad) de las cuatro variables del primer grupo.

Para la primera variable (Q18a_inv_LD) encontramos un intervalo entre [-3,60210; 3,06885]. Significa que el límite inferior excede 0,6 el triple del desvío padrón, mientras que el límite superior se mantiene dentro de los extremos que son aceptables. Este test fue repetido para todas las variables de escala. Seguidamente presentamos un resumen y detallamos los testes realizados de soporte a este proceso.

Nombre Variable	Skewness	Kurtosis	Mahlanobis Nº registros Pvalue<0,001	Transform						Z-Score		Observaciones
				LG ₁₀ Skewness	LG ₁₀ Kurtosis	SQR Skewness	SQR Kurtosis3	REVERSE Skewness	REVERSE Kurtosis	Lower limit	Upper limit	
Q18a_inv_LD	0,814	3,589	528	-1,442	10,263	-0,12	5,174	4,984	36,403	-3,602 ¹	3,069	Original
Q18b_inv_LD	-0,276	1,348	515	-1,887	7,015	-0,978	3,203	4,097	21,273	-3,269 ¹	2,623	Original
Q18c_inv_LD	1,000	2,699	568	-0,87	8,934	0,282	4,035	4,959	44,078	-3,702 ¹	2,937	Original
Q18d_inv_LD	0,812	0,528	-	-	-	-	-	-	-	-3,489 ¹	2,281	Original
Q29f_inv_LD	3,135	10,135	1961	2,046	3,306	2,525	6,11	-1,538	0,716	-2,733	0,522	Sobre REVERSE
Q29g_inv_LD	2,447	5,418	2162	1,605	1,361	1,986	3,081	-1,171	-0,353	-2,280	0,607	Sobre REVERSE
Q29h_inv_LD	3,268	11,293	2109	2,108	3,657	2,613	6,746	-1,585	0,879	-2,824	0,512	Sobre REVERSE
Q29i_inv_LD	2,729	6,763	2209	1,944	2,572	2,307	4,418	-1,510	0,578	-2,526	0,526	Sobre REVERSE
Q30a_inv_LD	0,847	-0,528	-	-	-	-	-	-	-	-0,931	2,181	Original
Q30b_inv_LD	3,242	9,930	20	2,473	4,988	2,831	7,194	-2,039	2,497	-2,983	0,429	Sobre REVERSE
Q30c_inv_LD	1,476	1,247	727	0,697	-0,861	1,058	0,011	-0,257	-1,677	-0,866	2,138	Sobre LOG ₁₀
Q30d_inv_LD	0,199	-1,426	841	-0,379	-1,293	-0,077	-1,429	0,900	-0,808	-0,906	1,714	Sobre REVERSE
Q29a_inv_LD	2,017	2,958	1647	1,384	0,486	1,682	1,581	-1,011	0,744	-2,036	0,650	Sobre REVERSE
Q29b_inv_LD	1,472	1,089	1806	0,773	-0,813	1,101	-0,007	-0,360	-1,626	-0,823	2,123	Sobre LOG ₁₀
Q29c_inv_LD	1,739	2,317	1635	0,957	-0,443	1,303	0,653	-0,564	-1,448	-0,748	2,442	Sobre LOG ₁₀
Q29d_inv_LD	1,941	3,469	1627	1,071	-0,149	1,440	1,213	-0,681	-1,300	-0,709	2,698	Sobre LOG ₁₀
Q29e_inv_LD	2,521	5,590	1413	1,766	1,850	2,114	3,483	1,35	0,099	-2,377	0,561	Sobre REVERSE
Q30e_inv_LD	0,091	-1,512	173	-0,418	-1,373	-0,158	-1,492	0,835	-1,027	-0,879	1,621	Sobre REVERSE
Q30f_inv_LD	-0,066	-1,641	168	-0,505	-1,340	-0,272	-1,529	0,906	-0,914	-0,813	1,669	Sobre REVERSE
Q30g_inv_LD	1,158	0,277	97	0,311	-1,073	0,738	-0,518	0,313	-1,484	-1,028	2,133	Sobre SQR
Q30h_inv_LD	1,301	1,080	81	0,341	-0,992	0,792	-0,203	0,237	-1,564	-1,007	2,545	Sobre SQR
Q30i_inv_LD	0,197	-1,604	151	-0,227	-1,591	-0,008	-1,622	0,572	-1,468	-0,933	1,411	Sobre REVERSE

Presentamos estos datos a modo de ejemplo. La tabla completa con la totalidad de los datos se encuentra en la sección final "Sección de Tablas", bajo el título "Tabla 1".

Figura 6 - figura de la tabla 1

Con todo ello, introducimos el análisis Mahalanobis para las variables de escala que superior a la unidad en valor absoluto), con el fin de poder detectar un posible número de registros con $Pvalue \leq 0,001$ (outliers). Seguidamente, para dichas variables llevamos a cabo transformaciones de tipo LOG_{10} , SQR y REVERSE, pudiendo detectar cuál de las transformadas presenta un valor inferior tanto de Skewness como Kurtosis entre sí y respecto de la variable original. Esta decisión de elección de qué variable transformada servirá mejor a efectos de normalidad está basada en una ponderación de sensibilidad, ya que no existe una única solución. Elegida la variable transformada, calculamos los límites inferiores y superiores de Z-Score que resultaban menores, es decir, más cercanos entre sí. La prueba Z-Score nos permite detectar los registros que trascienden el límite considerado como aceptable de ± 3.0 , con finalidad de poder más adelante eliminar registros en el caso de que la variable no se compatibilice con su constructo.

5. Análisis PCA

En esta fase procedemos a buscar factores de constructo que puedan agregar grupos de variables predictivas. Para este efecto, realizamos este tipo de análisis sobre un solo tipo de variables; de escala. El análisis PCA es, en verdad, una búsqueda de regresiones factoriales entre predictores y variables latentes que puedan representarlos.

La metodología seguida empieza por un análisis a la consistencia interna de las escalas que podrán potenciar un constructo, hecha a través del teste α Cronbach, por lo cual, siempre que sea posible, deberá retirarse un valor $\geq 0,7$. El proceso en este teste nos permite condensar suprimiendo variables, de manera que las restantes mejoren el indicador α Cr. Proseguimos con el paso siguiente del estudio a través del análisis a la conveniencia de datos por vía de dos testes, KMO (Kaiser-Meyer-Olkin) y Bartlett's Sphericity test. El criterio adoptado empieza por el KMO, lo cual tiene como medida mínima aceptable valores a partir de 0,6 en adelante, refiriéndose a la totalidad de las correlaciones encontradas. El teste de Bartlett mide la nulidad de la hipótesis de que la matriz de correlación sea de tipo identidad, es decir, la diagonal 1 y el resto 0. Encontrándose un valor o resultado significativo ($<0,05$), la matriz no es matriz identidad, rechazándose la hipótesis nula, por lo que las variables se relacionan entre sí lo suficiente para resultar en un valor significativo. Sobresalen dos medidas, el teste χ^2 y la cantidad de grados de libertad (cuanto mayores mejor). Se prosigue con el análisis de las comunalidades (la extensión por la cual un ítem se correlaciona con los demás) que tienen como valor mínimo 0,3. La matriz de datos sufrirá una rotación, que, en este caso, para grandes conjuntos de datos, la recomendable es Promax (rotación oblicua). De todos los outputs, uno destacable es la Pattern Matrix, que permite analizar las cargas por factores y los Cross-loadings. A medida que presentamos los análisis realizados, comentaremos, en los casos oportunos, los diferentes cuadros resultantes.

Comenzamos con el análisis de la variable Q18, presentando a continuación los cuadros más relevantes. Previamente al PCA se produce un análisis de la consistencia interna de las escalas, para verificar el nivel del α Cronbach, aceptándose valores mínimos de 0,6. Correlaciones ítem-total inferiores a 0,3 deberán ser consideradas con vista a su eliminación.

Reliability Statistics

Cronbach's Alpha	Cronbach's Alpha Based on Standardized Items	N of Items
,658	,660	4

Tabla VIII

Item-Total Statistics

	Scale Mean if Item Deleted	Scale Variance if Item Deleted	Corrected Item-Total Correlation	Squared Multiple Correlation	Cronbach's Alpha if Item Deleted
Q18a_inv_LD	9,8682	2,201	,407	,181	,611
Q18b_inv_LD	9,8091	2,124	,354	,143	,650
Q18c_inv_LD	9,7976	2,057	,500	,307	,551
Q18d_inv_LD	9,6093	1,851	,505	,330	,541

Tabla IX

En el primer cuadro, el valor a considerar para este análisis es el correspondiente a la primera columna, mientras en el segundo cuadro serían las correspondientes a “Corrected Item-TotalCorrelation” y “Cronbach’s Alpha if Item Deleted”. En este caso se podrá verificar la existencia de correlaciones aceptables Item-Total, y la eliminación de cualquiera de las variables no supondría mejoras al α Cronbach. En conclusión, se mantienen los cuatro ítems para proseguir los testes PCA.

El siguiente cuadro se refiere a correlaciones entre el ítem y las demás variables, mirándose en cada columna (ítem) dichas correlaciones, siendo conveniente que iguallen o superen 0,3.

Correlation Matrix

	Q18a_inv_LD	Q18b_inv_LD	Q18c_inv_LD	Q18d_inv_LD
Correlation Q18a_inv_LD	1,000	,290	,251	,369
Q18b_inv_LD	,290	1,000	,306	,227
Q18c_inv_LD	,251	,306	1,000	,519
Q18d_inv_LD	,369	,227	,519	1,000

Tabla X

Seguidamente, se presenta el teste KMO y Bartlett, verificándose que el teste KMO está en el umbral mínimo para que pueda aceptarse el análisis factorial, encontrándose significancia en las correlaciones “ $P < 0,05$ ”, a través del teste de Bartlett.

KMO and Bartlett's Test

Kaiser-Meyer-Olkin Measure of Sampling Adequacy.		,646
Bartlett's Test of Sphericity	Approx. Chi-Square	18767,500
	df	6
	Sig.	,000

Tabla XI

El cuadro siguiente presenta las comunalidades entre ítems, verificándose que son todas superiores a 0,4.

Communalities

	Initial	Extraction
Q18a_inv_LD	1,000	,435
Q18b_inv_LD	1,000	,367
Q18c_inv_LD	1,000	,580
Q18d_inv_LD	1,000	,610

Extraction Method: Principal Component Analysis.

Tabla XII

Seguimos con el cuadro de varianza explicada y el Scree Plot. Del cuadro de varianza resultó un solo factor que agrega las cuatro variables, lo cual queda evidenciado por haber un solo componente con Eigenvalue superior a la unidad. El total de varianza explicada es de aproximadamente el 50%, equivaliendo éste al valor mínimo para ser aceptado.

Total Variance Explained

Component	Initial Eigenvalues			Extraction Sums of Squared Loadings		
	Total	% of Variance	Cumulative %	Total	% of Variance	Cumulative %
1	1,993	49,825	49,825	1,993	49,825	49,825
2	,824	20,599	70,425			
3	,740	18,496	88,921			
4	,443	11,079	100,000			

Extraction Method: Principal Component Analysis.

Tabla XIII



Figura 7

Al haberse producido un único factor, no se logró la rotación. La matriz de componentes principales es presentada más abajo, indicando las cargas de cada ítem en el factor.

Component Matrix^a

	Component
	1
Q18d_inv_LD	,781
Q18c_inv_LD	,762
Q18a_inv_LD	,660
Q18b_inv_LD	,606

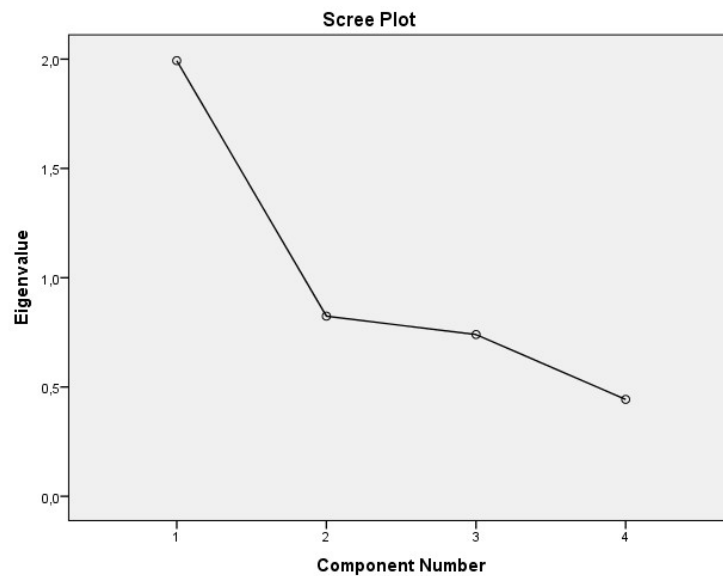
Extraction Method: Principal Component Analysis.

a. 1 components extracted.

Tabla XIV

En cuanto el criterio de KMO y el Scree Plot son útiles para determinar el número de factores a extraer, la confirmación final es lograda con el PARALLEL analysis (O'Connor, 2000), que es un criterio bien más robusto. La Parallel analysis sólo puede ser hecha utilizando el módulo syntax SPSS. La lógica de análisis, es que cuando se encuentra un Eigenvalue inferior al valor presentado en la columna Prcentyle, es ahí estimada la línea de corte de la cantidad de factores.

```
Run MATRIX procedure:

Specifications for this Run:
Ncases      30318
Nvars       4
Ndatsets    1000
Percent     95

Random Data Eigenvalues
      Root      Means      Prcentyle
1,000000000  1,012565751  1,019902842
2,000000000  1,003618285  1,008424124
3,000000000  ,996440426   1,000222436
4,000000000  ,987375538   ,993322940

----- END MATRIX -----
```

Tabla XV

Como se puede verificar, el Eigenvalue de la segunda línea del cuadro de varianza total explicada, es 0,824, valor éste inferior a 1,008, lo que confirma la extracción de un solo componente.

Presentamos a continuación el estudio PCA de la cuestión Q29.

Inicialmente, utilizamos las variables transformadas del estudio de normalidad para el teste del α Cronbach y seguidamente a éste teste y al análisis factorial, surgieron cargas negativas mezcladas con las demás para un solo factor, tal hecho determinaría la inversión de escalas, rehaciéndose el estudio desde el inicio. Ponderadas las razones de haber ocurrido para un mismo factor polaridades contrarias de un conjunto de variables, concluimos que esto se debe a mezclar medidas de escala con transformaciones logarítmicas y otras transformaciones provenientes de nuestros intentos para aproximar a la normalidad cada una de las variables. Por tanto, rehicimos el teste empleando las variables originales de la base de datos antes de su transformación, obteniendo resultados mejorados en comparación con los anteriores.

Para efectos del α Cronbach presentamos lo mismo seguidamente.

Reliability Statistics		
Cronbach's Alpha	Cronbach's Alpha Based on Standardized Items	N of Items
.821	.822	9

Tabla XVI

Item-Total Statistics

	Scale Mean if Item Deleted	Scale Variance if Item Deleted	Corrected Item-Total Correlation	Squared Multiple Correlation	Cronbach's Alpha if Item Deleted
SMEAN (Q29a_inv_ReplaceMD)	13,7763	50,419	,601	,433	,793
SMEAN (Q29b_inv_ReplaceMD)	13,4314	49,707	,583	,410	,796
SMEAN (Q29c_inv_ReplaceMD)	13,6725	52,479	,559	,356	,799
SMEAN (Q29d_inv_ReplaceMD)	13,8131	55,026	,504	,302	,805
SMEAN (Q29e_inv_ReplaceMD)	13,9880	51,894	,636	,445	,789
Q29f_inv_LD	14,1628	55,450	,601	,453	,797
Q29g_inv_LD	13,9615	54,339	,522	,433	,803
Q29h_inv_LD	14,1965	59,584	,373	,150	,819
Q29i_inv_LD	14,0506	57,970	,340	,236	,824

Tabla XVII

El análisis KMO, las comunalidades y la varianza explicada son mostrados a continuación.

KMO and Bartlett's Test

Kaiser-Meyer-Olkin Measure of Sampling Adequacy.		,856
Bartlett's Test of Sphericity	Approx. Chi-Square	80817,876
	df	36
	Sig.	,000

Tabla XVIII

Communalities

	Initial	Extraction
SMEAN (Q29a_inv_ReplaceMD)	1,000	,586
SMEAN (Q29b_inv_ReplaceMD)	1,000	,589
SMEAN (Q29c_inv_ReplaceMD)	1,000	,521
SMEAN (Q29d_inv_ReplaceMD)	1,000	,465
SMEAN (Q29e_inv_ReplaceMD)	1,000	,581
Q29f_inv_LD	1,000	,629
Q29g_inv_LD	1,000	,733
Q29h_inv_LD	1,000	,247
Q29i_inv_LD	1,000	,644

Tabla XIX

Extraction Method: Principal Component Analysis.

Total Variance Explained

Component	Initial Eigenvalues			Extraction Sums of Squared Loadings			Rotation Sums of Squared Loadings ^a
	Total	% of Variance	Cumulative %	Total	% of Variance	Cumulative %	
1	3,778	41,982	41,982	3,778	41,982	41,982	3,510
2	1,219	13,539	55,521	1,219	13,539	55,521	2,571
3	,854	9,484	65,005				
4	,761	8,452	73,457				
5	,608	6,752	80,209				
6	,516	5,735	85,944				
7	,466	5,182	91,126				
8	,421	4,679	95,805				
9	,378	4,195	100,000				

Extraction Method: Principal Component Analysis.

a. When components are correlated, sums of squared loadings cannot be added to obtain a total variance.

Tabla XX

Pattern Matrix^a

	Component	
	1	2
SMEAN (Q29b_inv_ReplaceMD)	,799	
SMEAN (Q29a_inv_ReplaceMD)	,773	
SMEAN (Q29c_inv_ReplaceMD)	,734	
SMEAN (Q29d_inv_ReplaceMD)	,715	
SMEAN (Q29e_inv_ReplaceMD)	,682	
Q29h_inv_LD	,479	
Q29i_inv_LD		,874
Q29g_inv_LD		,839
Q29f_inv_LD		,627

Extraction Method: Principal Component Analysis.
 Rotation Method: Promax with Kaiser Normalization.^a

a. Rotation converged in 3 iterations.

Tabla XXI

Sigue la confirmación de los factores extraídos, a través de la Parallel analysis.

Run MATRIX procedure:

Specifications for this Run:

Ncases 30318
 Nvars 9
 Ndatsets 1000
 Percent 95

Random Data Eigenvalues

	Root	Means	Prcntyle
1,000000000	1,026082727	1,033493287	
2,000000000	1,017790788	1,023103332	
3,000000000	1,011177797	1,015816072	
4,000000000	1,005409152	1,009599055	
5,000000000	,999809354	1,003750646	
6,000000000	,994380978	,998388078	
7,000000000	,988687917	,992899323	
8,000000000	,982360801	,987335055	
9,000000000	,974300485	,980571603	

Tabla XXII

Hemos seguido el procedimiento explicado para el resto de variables de escala, por lo que mostramos a continuación un cuadro resumen del resto de resultados obtenidos para todas estas variables de escala.

Question	Variables	Variables deleted Groups Comments	α		Total variance explained	Nr. Factors	Confirm. Parallel Analysis	Correlation Matrix \leq	Pattern Matrix			
			Cronbach	Test KMO					Factor 1	Factor 2	Factor 3	Factor 4
Q18	TOTAL		0,658	0,646	49,825%	1	Y	-				
	Q18a_inv_LD								0,660*			
	Q18b_inv_LD								0,606*			
	Q18c_inv_LD								0,762*			
	Q18d_inv_LD								0,781*			
Q29	TOTAL		0,821	0,856	55,521%	2	Y	0,465				
	Q29a_inv_ReplaceMD_1								0,773			
	Q29b_inv_ReplaceMD_1								0,799			
	Q29c_inv_ReplaceMD_1								0,734			
	Q29d_inv_ReplaceMD_1								0,715			
	Q29e_inv_ReplaceMD_1								0,682			
	Q29f_inv_LD									0,627		
	Q29g_inv_LD									0,839		
	Q29h_inv_LD								0,479			
	Q29i_inv_LD									0,874		

Presentamos estos datos a modo de ejemplo. La tabla completa con la totalidad de los datos se encuentra en la sección final "Sección de Tablas", bajo el título "Tabla 2".

Figura 8 - figura de la tabla 2









































La estructura de factores mostrada en la tabla anterior corresponde a todas las variables de escala que han de ser consideradas a efectos de modelización.

6. Análisis de variables nominales y ordinales

Los análisis realizados respecto a las variables nominales y ordinales se basaron en tres etapas: (a) análisis entre variables nominales dentro de cada grupo teórico buscando relaciones y, además, fue igualmente estudiada la relación entre la variable Q20 con todas las restantes nominales; (b) análisis entre variables nominales y ordinales; (c) análisis entre variables ordinales, además de estudiar las relaciones entre la variable ordinal sintética creada (Q22_Rect) a partir de las tres variables dummies Q22 y el resto de variables ordinales.

Fueron creadas variables sintéticas de tipo ordinal, a partir las opciones existentes en determinadas cuestiones. Los criterios seguidos para la creación de estas variables fueron la elección de cuestiones que: (1) permitían respuestas múltiples, (2) presentaban un conjunto de opciones de complementariedad, ó (3) dichas opciones describían diferentes vertientes del mismo tema. El motivo de creación de estas variables sintéticas se basa en la intención de ser capaces de analizar exhaustivamente las posibilidades de asociación y de regresión, que puedan ser útiles en la etapa de generación de los modelos de medida mediante la metodología PLS.

El cuadro siguiente muestra todas las variables que fueron objeto de nuestro estudio. Aparte del análisis de relaciones entre Q20 con todas las nominales restantes, el criterio seguido para estudiar las restantes fue lo de evaluar niveles de asociación entre variables dentro del mismo grupo teórico, a partir del marco teórico que fue proporcionado.

VARIABLES NOMINAL AND ORDINAL				
NOMINAL		SUMMARY VARIABLE	ORDINAL	Summary Var. *
 Q20_dic			 Q22_Rect	Rebuilt
 Q22_dummy1			 Q24_cat	Workload & workspace
 Q22_dummy2			 Q26_cat	Workload & workspace
 Q22_dummy3			 Q36_cat	Home – work interfece
 Q64_aRect	Career Development		 Q64_TOTAL	Career Development *
 Q64_bRect	Career Development	 Q64_TOTAL	 Q65_TOTAL	Career Development *
 Q64_cRect	Career Development		 Q42_TOTAL	Control *
 Q65a_dic_MV	Career Development		 Q50_TOTAL	Control *
 Q65b_dic_MV	Career Development		 Q52_TOTAL	Control *
 Q65c_dic_MV	Career Development		 Q54_TOTAL	Control *
 Q65d_dic_MV	Career Development	 Q65_TOTAL	 Q72_TOTAL	Environment & equipment *
 Q42_dic1	Control		 Q80_TOTAL	Environment & equipment *
 Q42_dic2	Control		 Q81_TOTAL	Environment & equipment *
 Q42_dic3	Control		 Q23_cat	Job content
 Q42_dic4	Control	 Q42_TOTAL	 Q48_TOTAL	Job content *
 Q50a_dic_MV	Control		 Q71_TOTAL	Organizational Culture *
 Q50b_dic_MV	Control		 Q78_TOTAL	Resultados y efectos *
 Q50c_dic_MV	Control			
 Q50d_dic_MV	Control			
 Q50e_dic_MV	Control	 Q50_TOTAL		

Presentamos estos datos a modo de ejemplo. La tabla completa con la totalidad de los datos se encuentra en la sección final “Sección de Tablas”, bajo el título “Tabla 3”.

Figura 9 - figura de la tabla 3

6.1 Relaciones entre variables nominales - Metodologías y guías

El test de análisis de relaciones entre variables nominales se designa como χ^2 test of independence, es una estadística no paramétrica, no tiene asunciones de normalidad ni de homocedasticidad, y puede ser utilizado en distribuciones demasiado desviadas o curtódicas para tests paramétricos. El principio funcional es testar la hipótesis nula, según la cual las dos variables son independientes. Si el resultado de la significancia obtenida a partir de uno de estos tres tests (Pearson's χ^2 , el Fisher's Exact Test o el Likelihood Ratio) asume un $p_{value} < 0,05$, eso significará que existe asociación entre las dos variables, por lo que se rechazará la hipótesis nula.

El test de Pearson's χ^2 es utilizado cuando las variables permiten la creación de una matriz simétrica (ej., 2x2) y se verifica la asunción de que en cada una de las células hay un expected count $\geq 10\%$. Cuando hay violación de esta asunción se utiliza el Fisher's Exact Test. Cuando la matriz es asimétrica se emplea la medida proporcionada por el test de Likelihood Ratio.

Adicionalmente a las tres medidas anteriores, se utilizó el test Phi and Cramer's V, lo cual mide el nivel de asociación entre las dos variables, ó sea, la importancia de dicha asociación. La guía que seguimos es considerarlas cómo independientes si hay un valor igual a 0 ó inferior al umbral de 0,1. Valores iguales ó inferiores a 0,2 representan bajos niveles de relación, relaciones moderadas para valores iguales ó inferiores al 0,3, y una fuerte relación por encima de 0,3.

Presentamos seguidamente un ejemplo del Output obtenido a partir de la estadística descriptiva Crosstabs de SPSS.

Crosstabs

Case Processing Summary						
	Cases					
	Valid		Missing		Total	
	N	Percent	N	Percent	N	Percent
Q20_dic_MV * Q65a_dic_MV	30318	100,0%	0	0,0%	30318	100,0%

Q20_dic_MV * Q65a_dic_MV Crosstabulation						
			Q65a_dic_MV		Total	
			,00	1,00		
Q20_dic_MV	,00	Count	14839	7997	22836	
		Expected Count	13903,6	8932,4	22836,0	
		% within Q20_dic_MV	65,0%	35,0%	100,0%	
Q20_dic_MV	1,00	Count	3620	3862	7482	
		Expected Count	4555,4	2926,6	7482,0	
		% within Q20_dic_MV	48,4%	51,6%	100,0%	
Total		Count	18459	11859	30318	
		Expected Count	18459,0	11859,0	30318,0	
		% within Q20_dic_MV	60,9%	39,1%	100,0%	

Tabla XXIII

Chi-Square Tests

	Value	df	Asymptotic Significance (2-sided)	Exact Sig. (2-sided)	Exact Sig. (1-sided)
Pearson Chi-Square	651,915 ^a	1	,000		
Continuity Correction ^b	651,218	1	,000		
Likelihood Ratio	641,281	1	,000		
Fisher's Exact Test				,000	,000
Linear-by-Linear Association	651,893	1	,000		
N of Valid Cases	30318				

a. 0 cells (.0%) have expected count less than 5. The minimum expected count is 2926,61.

b. Computed only for a 2x2 table

Symmetric Measures

	Value	Approximate Significance
Nominal by Nominal Phi	,147	,000
Cramer's V	,147	,000
N of Valid Cases	30318	

Tabla XXIV

Las tablas siguientes sintetizan todos los resultados obtenidos y respectivos comentarios.

Variable tested	Association with	Statistics <i>p</i> value (2-sided)								Comments
		Pearson's χ^2		Likelihood Ratio		Fisher's Exact Test		Cramer's V		
		Sig	Non-sig.	Sig	Non-sig.	Sig	Non-sig.	Value	Sig	
Q20_dic	Q22_dummy1	0,536	-	-	-	-	-	-	-	Not associated, <i>p</i> value exceeds 0,05 threshold
	Q22_dummy2	0,699	-	-	-	-	-	-	-	Not associated, <i>p</i> value exceeds 0,05 threshold
	Q22_dummy3	0,167	-	-	-	-	-	-	-	Not associated, <i>p</i> value exceeds 0,05 threshold
	Q64_aRect	0,000	-	-	-	-	-	0,070	0,000	Very low relation, Cramer almost null
	Q64_bRect	0,000	-	-	-	-	-	0,058	0,000	Very low relation, Cramer almost null
	Q64_cRect	0,078	-	-	-	-	-	-	-	Not associated, <i>p</i> value exceeds 0,05 threshold
	Q65a_dic_MV	0,000	-	-	-	-	-	0,147	0,000	Low relation, Cramer less than 0,2
	Q65b_dic_MV	0,000	-	-	-	-	-	0,048	0,000	Very low relation, Cramer almost null
	Q65c_dic_MV	0,000	-	-	-	-	-	0,140	0,000	Low relation, Cramer less than 0,2
	Q65d_dic_MV	0,000	-	-	-	-	-	0,089	0,000	Very low relation, Cramer almost null
	Q42_dic1	0,000	-	-	-	-	-	0,113	0,000	Low relation, Cramer less than 0,2
	Q42_dic2	0,068	-	-	-	-	-	-	-	Not associated, <i>p</i> value exceeds 0,05 threshold
	Q42_dic3	0,000	-	-	-	-	-	0,116	0,000	Low relation, Cramer less than 0,2
	Q42_dic4	0,000	-	-	-	-	-	0,022	0,000	Very low relation, Cramer almost null

Presentamos estos datos a modo de ejemplo. La tabla completa con la totalidad de los datos se encuentra en la sección final "Sección de Tablas", bajo el título "Tabla 4".

Figura 10 - figura de la tabla 4

6.2 Análisis entre variables nominales y ordinales – Metodologías y guías

Este análisis está agregado en un conjunto de tests titulados Non-Parametrics inferencial statistics. La estadística a utilizar es la de Mann-Whitney U Test, apropiado para analizar grupos de variables independientes (datos ordinales y nominales). Mediante este estudio se busca rechazar la hipótesis nula a través de la significancia, por lo que obteniendo un $p_{\text{value}} < 0,05$ se constata la existencia de distribución distinta entre los grupos (variables).

Más abajo presentamos el output de uno de los testes ejecutados en SPSS.

Nonparametric Tests

	Null Hypothesis	Test	Sig.	Decision
1	The distribution of Q24_cat Total of working hours per week is the same across categories of Q20_dic_MV.	Independent-Samples Mann-Whitney U Test	,000	Reject the null hypothesis.

Tabla XXV

Asymptotic significances are displayed. The significance level is ,05.







Figura 11

A continuación, presentamos el cuadro completo de los valores obtenidos, así como los comentarios referentes a cada par de variables.

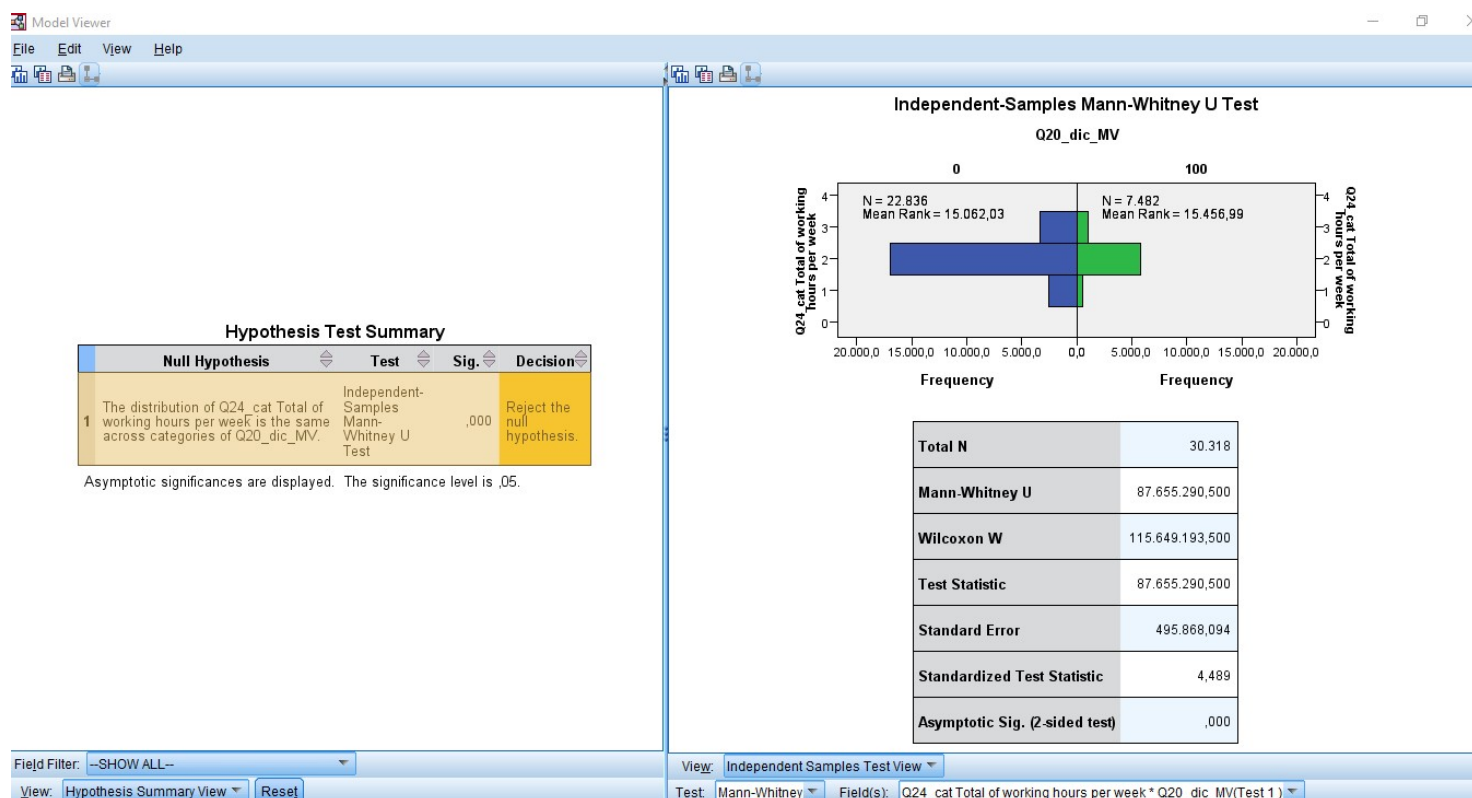
Variable tested	Association with	Non-parametric inferential Statistics <i>p</i> value (2-sided)						Comments
		Mann-Whitney U Test		H0 Hypothesis		Standardized Test statistics		
		Sig	Non-sig.	Reject	Accept	Value	Asym. Sig.	
 Q20_dic	 Q22_Rect		0,056		Yes	1,910	0,056	The distribution of Q22_Rect is the same across categories of Q20_dic, therefore H0 is accepted
	 Q24_cat		0,000		Yes	4,489	0,000	People whose workplace didn't suffered any reorganization (Q20, value 0), are more likely to work between 22 till 45 hours/week (Q24, cat.2)
	 Q26_cat		0,000		Yes	-10,789	0,000	People whose workplace didn't suffered any reorganization (Q20, value 0), are much more likely to work 5 days/week (Q26, cat.2)

Presentamos estos datos a modo de ejemplo. La tabla completa con la totalidad de los datos se encuentra en la sección final "Sección de Tablas", bajo el título "Tabla 5".

Figura 12 - figura da la tabla 5

6.3 Análisis entre variables ordinales – Metodología y guías

En este paso comparamos pares de variables ordinales a través de metodología no paramétrica, cuya estadística más adecuada es la de Wilcoxon Signed-Rank Test. El análisis calcula la mediana de las diferencias entre la puntuación en cada línea de datos asociados a cada variable, y si el resultado final logra ser 0, la hipótesis nula es aceptada, debido a la significancia de $p_{\text{value}} \geq 0,05$ por lo que las dos variables serán independientes.

A continuación, presentamos un ejemplo del output para un par de variables, del conjunto completo de análisis que componen este estudio, hecho a través del SPSS.

Nonparametric Tests

	Null Hypothesis	Test	Sig.	Decision
1	The median of differences between Q22_Rect and Q42_TOTAL equals 0.	Related-Samples Wilcoxon Signed Rank Test	,000	Reject the null hypothesis.

Asymptotic significances are displayed. The significance level is ,05.

Tabla XXVI



Figura 13

NPar Tests

Descriptive Statistics					
	N	Mean	Std. Deviation	Minimum	Maximum
Q22_Rect	30318	1,70	,600	0	3
Q42_TOTAL	30318	1,59	,942	1	4

Tabla XXVII

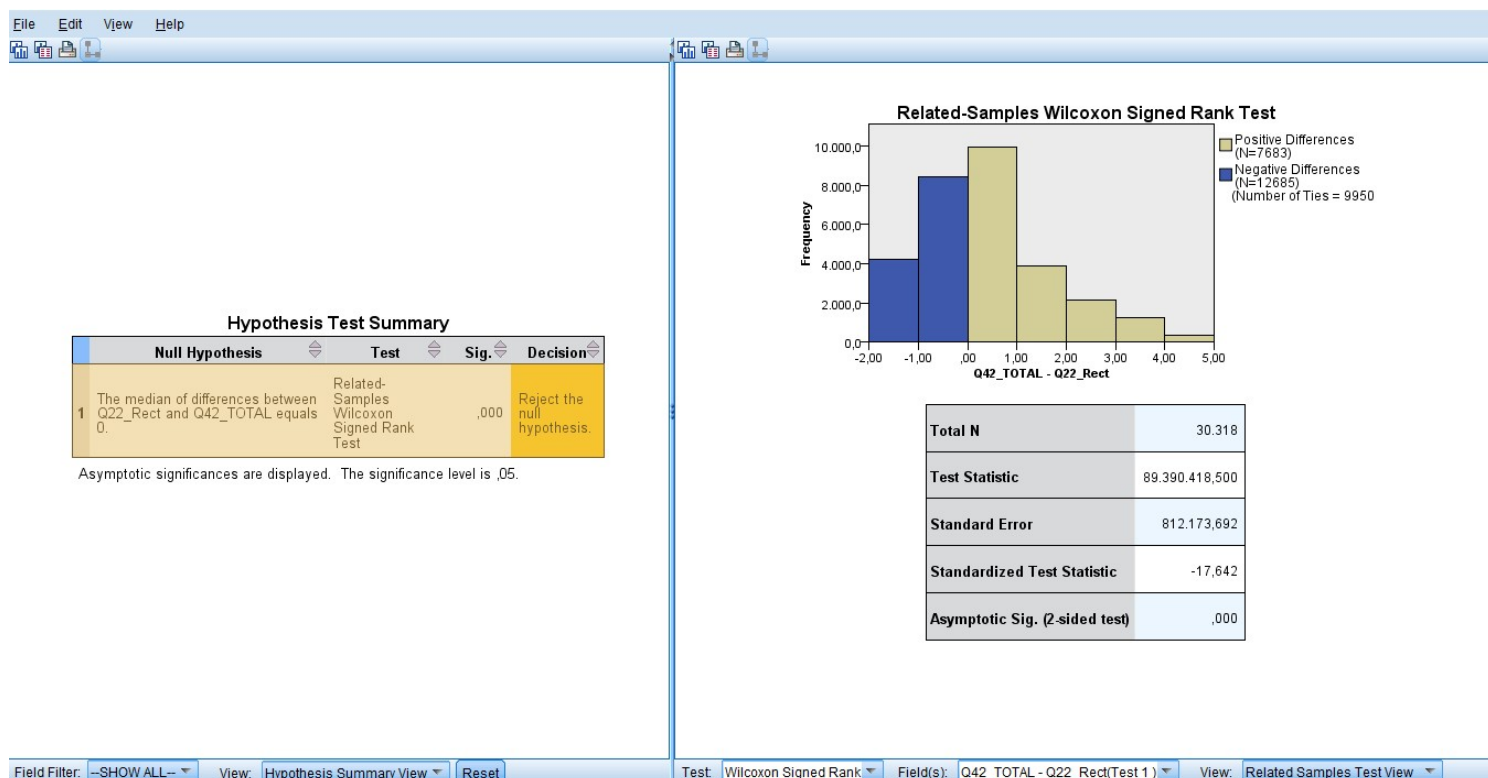
Wilcoxon Signed Ranks Test

Ranks				
		N	Mean Rank	Sum of Ranks
Q42_TOTAL - Q22_Rect	Negative Ranks	12685 ^a	9306,07	118047477,50
	Positive Ranks	7683 ^b	11634,83	89390418,50
	Ties	9950 ^c		
	Total	30318		

- a. Q42_TOTAL < Q22_Rect
- b. Q42_TOTAL > Q22_Rect
- c. Q42_TOTAL = Q22_Rect

Tabla XXVIII

Test Statistics ^a	
	Q42_TOTAL - Q22_Rect
Z	-17,642 ^b
Asymp. Sig. (2-tailed)	,000

Tabla XXIX

- a. Wilcoxon Signed Ranks Test
- b. Based on positive ranks.

Seguidamente, presentamos el cuadro completo de los valores obtenidos, así como los comentarios referentes a cada par de variables.

Variable tested	Association with	Non-parametric inferential Statistics <i>p</i> value (2-sided)								Comments	
		Wilcoxon Signed-Rank Test		H0 Hypothesis		Standerdized Test statistics		MEAN			Z Test
		Sig	Non-sig.	Reject	Accept	Value	Sig. (2-sided)	Var. 1	Var. 2		Value
Variable 1 Q22_Rect	Variable 2 Q24_cat	0,000		Yes		54,183	0,000	1,70	2,04	-54,183	When at the workplace there is a groing trend for decrease of the majority of men, approaching the gender balance (Q22, value 1 to 2), there is a positive relationship with the amount of hours worked/week, which tends to be between 22 till 45 (Q24, value 2)
	Q26_cat	0,000		Yes		53,564	0,000	1,70	2,04	-53,564	When at the workplace there is a groing trend for decrease of the majority of men, approaching the gender balance (Q22, value 1 to 2), there is a positive relationship with the amount of days worked/week tends to be 5 (Q26, value 2)

Presentamos estos datos a modo de ejemplo. La tabla completa con la totalidad de los datos se encuentra en la sección final "Sección de Tablas", bajo el título "Tabla 6".

Figura 14 - figura da tabela 6

7. Asociaciones intra-grupo entre variables dependientes y variables cualitativas

En esta fase del trabajo procedemos al estudio de las potenciales asociaciones entre variables cualitativas, tanto nominales como ordinales en su cualidad de independientes, con las variables de escala consideradas como dependientes. La estadística recomendada es el cálculo de ETA, lo cual nos va a proporcionar cuatro patrones de medida de las asociaciones entre las variables independientes y cada dependiente, observando las relaciones dentro de cada grupo teórico. Los valores obtenidos que definen la asociación deberán encuadrarse en cuatro patrones, a saber: valores por debajo de 0,02 no presentan asociación; valores $\geq 0,02$ y $< 0,13$ representan asociación débil o pequeña; valores $\geq 0,13$ e $< 0,26$ corresponden a asociaciones moderadas; y valores $\geq 0,26$ son considerados representativos de asociaciones fuertes.

El método de análisis en SPSS supone la utilización de Crosstabs. Como complemento, medimos la capacidad explicativa de la variancia ofrecida por la regresión de la variable dependiente a la independiente, a través del valor Partial Eta-Square proporcionado por el test OneWay ANOVA, que en este caso ese valor es equivalente al cuadrado del valor de ETA. Concluyendo, el Partial Eta-Square corresponde a la proporción de variancia explicada a través de la variable independiente.

Como sugerencia, proponemos que tan solo sean utilizadas las regresiones que expliquen un valor de variancia $\geq 1\%$, puesto que, de considerar todos los valores, el análisis mediante PLS pasará a ser elevadamente complejo, conllevando un proceso demasiado lento para extraer conclusiones.

Presentamos seguidamente los cuadros de Output de los análisis Crosstabs y OneWay ANOVA y más abajo las tablas que resumen todos los valores obtenidos.

Crosstabs

Case Processing Summary						
	Cases					
	Valid		Missing		Total	
	N	Percent	N	Percent	N	Percent
Q45b_inv Working conditions - happening in last 12 months - very tired after work to take home duties * Q78a_dic_MV	30318	100,0%	0	0,0%	30318	100,0%

Q45b_inv Working conditions - happening in last 12 months - very tired after work to take home duties * Q78a_dic_MV Crosstabulation

Count		Q78a_dic_MV		Total
		,00	1,00	
Q45b_inv Working conditions - happening in last 12 months - very tired after work to take home duties	Never	5333	283	5616
	Rarely	6287	261	6548
	A few times	10946	665	11611
	Almost always	4552	375	4927
	Always	1468	148	1616
Total		28586	1732	30318

Directional Measures

			Value
Nominal by Interval	Eta	Q45b_inv Working conditions - happening in last 12 months - very tired after work to take home duties Dependent	,050
		Q78a_dic_MV Dependent	,060

Tabla XXXI

Univariate Analysis of Variance

Between-Subjects Factors

		N
Q78a_dic_MV	,00	28586
	1,00	1732

Descriptive Statistics

Dependent Variable: Q45b_inv Working conditions - happening in last 12 months - very tired after work to take home duties

Q78a_dic_MV	Mean	Std. Deviation	N
,00	2,67	1,105	28586
1,00	2,91	1,164	1732
Total	2,68	1,110	30318

Tests of Between-Subjects Effects

Dependent Variable: Q45b_inv Working conditions - happening in last 12 months - very tired after work to take home duties

Source	Type III Sum of Squares	df	Mean Square	F	Sig.	Partial Eta Squared
Corrected Model	94,878 ^a	1	94,878	77,207	,000	,003
Intercept	50826,024	1	50826,024	41359,295	,000	,577
Q78a_dic_MV	94,878	1	94,878	77,207	,000	,003
Error	37255,030	30316	1,229			
Total	255539,000	30318				
Corrected Total	37349,908	30317				

a. R Squared = ,003 (Adjusted R Squared = ,003)

Tabla XXXII

INTRA-GROUP ASSOCIATIONS BETWEEN QUALITATIVE AND SCALE VARIABLES

GROUP	Variables		ETA	Comments	Explained Variance
	Dependent	Independent	value		
Results & Effects	Q45a_inv	Q78a_dic_MV	0,058	Small relation	0,34%
		Q78b_dic_MV	0,091	Small relation	0,83%
		Q78c_dic_MV	0,111	Small relation	1,23%
		Q78d_dic_MV	0,138	MODERATE RELATION	1,90%
		Q78e_dic_MV	0,092	Small relation	0,85%
		Q78f_dic_MV	0,171	MODERATE RELATION	2,92%
		Q78g_dic_MV	0,052	Small relation	0,27%
		Q78h_dic_MV	0,244	MODERATE RELATION	5,95%
		Q78i_dic_MV	0,222	MODERATE RELATION	4,93%
Results & Effects	Q45b_inv	Q78a_dic_MV	0,050	Small relation	0,25%
		Q78b_dic_MV	0,087	Small relation	0,76%
		Q78c_dic_MV	0,220	MODERATE RELATION	4,84%
		Q78d_dic_MV	0,240	MODERATE RELATION	5,76%
		Q78e_dic_MV	0,224	MODERATE RELATION	5,02%
		Q78f_dic_MV	0,214	MODERATE RELATION	4,58%
		Q78g_dic_MV	0,072	Small relation	0,52%
		Q78h_dic_MV	0,221	MODERATE RELATION	4,88%

Presentamos estos datos a modo de ejemplo. La tabla completa con la totalidad de los datos se encuentra en la sección final "Sección de Tablas", bajo el título "Tabla 7".

Figura 15 - figura de la tabla 7

Tras el mencionado estudio, presentamos a continuación, para cada grupo teórico, un resumen de las variables consideradas relevantes (variancia explicada $\geq 1\%$) a efectos del análisis PLS, indicando en cada caso el tipo de variable en cuestión. Tal como se indica, la cantidad total de variables consideradas son: 61 nominales, 6 categóricas y 75 de escala.

Variable Name	Measure			Variable description	Group
	Nominal	Ordinal	Scale		
Total variables used	61	6	75		
Country	x			Country	Segmentation-model control
Q2a		x		Gender	Segmentation-model control
Q2b_cat		x		Age	Segmentation-model control
Q2d_resumen	x			Complete/partial day work	Segmentation-model control
Q11_a	x			Work contract type 1	Segmentation-model control
Q11_b	x			Work contract type 2	Segmentation-model control
Q11_c	x			Work contract type 3	Segmentation-model control
Q14_a	x			Private sector	Segmentation-model control
Q14_b	x			Public sector	Segmentation-model control
Q15a	x			Number of working centers	Segmentation-model control
Q16b		x		Amount of workers	Segmentation-model control

Presentamos estos datos a modo de ejemplo. La tabla completa con la totalidad de los datos se encuentra en la sección final “Sección de Tablas”, bajo el título “Tabla 8”.

Figura 16 - figura de la tabla 8

Finalmente, presentamos las relaciones existentes entre cada variable dependiente (escala) e independiente (nominales y ordinales), ordenadas en función de; (1) Grupo teórico al que pertenecen, (2) variable dependiente y (3) porcentaje de variancia explicada. Dicho cuadro será empleado para proceder al modelo de medida.

ASSOCIATIONS BETWEEN QUALITATIVE CONTROL/SEGMENTATION VARIABLES AND SCALE VARIABLES

GROUP	$\Delta\Delta$		$\Delta\Delta$			ETA value	Comments	Δ Explained Variance
	Dependent	Independent	Measure	Type				
Control	Q43_inv	Q42_dic3	Nominal	dic.	0,674	STRONG RELATION	45,43%	
Control	Q43_inv	Q42_dic1	Nominal	dic.	0,668	STRONG RELATION	44,62%	
Control	Q43_inv	Q42_dic4	Nominal	dic.	0,318	STRONG RELATION	10,11%	
Control	Q43_inv	Country	Nominal		0,313	STRONG RELATION	9,80%	
Control	Q43_inv	Q54a_dic_MV	Nominal	dic.	0,165	MODERATE RELATION	2,72%	
Control	Q43_inv	Q54b_dic_MV	Nominal	dic.	0,140	MODERATE RELATION	1,96%	
Control	Q43_inv	Q52_dic2	Nominal	dic.	0,131	MODERATE RELATION	1,72%	
Control	Q43_inv	Q52_dic1	Nominal	dic.	0,126	Small relation	1,59%	
Control	Q43_inv	Q16b	Ordinal		0,119	Small relation	1,42%	
Control	Q43_inv	Q15a	Nominal	dic.	0,104	Small relation	1,08%	

Presentamos estos datos a modo de ejemplo. La tabla completa con la totalidad de los datos se encuentra en la sección final “Sección de Tablas”, bajo el título “Tabla 9”.

Figura 17 - figura de la tabla 9

8. Estudios en PLS

A fin de estudiar el modelo pretendido, se ha utilizado el programa SmartPls 3 (Ringle, Wende y Becker, 2015), Boenningstedt: SmartPls GmbH, <http://www.smartpls.com> versión 3.2.9 profesional.

De las razones por las cuales se recurre al SmartPls, una se debe al hecho de usar el método de análisis de los mínimos cuadrados parciales (PLS) con modelación mediante ecuaciones estructurales (SEM), a fin de testar los caminos que constan en el modelo de investigación, los cuales unen variables predictivas a variables latentes, y conectan los constructos aplicados en el modelo. Como uno de los objetivos implícitos en la modelación es evaluar el establecimiento y la naturaleza de relaciones causales entre diferentes variables implicadas, el método de las ecuaciones estructurales es el más apropiado, siendo una poderosa técnica de análisis multivariante (Mackenzie, Podsakoff y Jarvis, 2005; Hair, Anderson, Tatham y Black, 2000, Bollen y Lenox, 1991).

Por otro lado, el PLS concede la facilidad de generar y estudiar, en simultáneo, modelos de medida formativos y reflectivos, dominio éste de gran obstáculo para instrumentos que utilizan la modelización SEM basada en covarianza (Henseler, Ring y Sinkovics, 2009; Chin, 1998).

Otra razón destacable que asiste a la elección de esta metodología tiene que ver con el superior poder estadístico ofrecido por el PLS-SEM, para modelos complejos, lo que corresponde al caso.

Igualmente importa señalar que, del análisis holístico desarrollado por los SEM (structural equations modeling), el abordaje aportado por la metodología PLS respecto a técnicas estadísticas (PLS-SEM, análisis basadas en componentes dichos compuestos) difiere de los métodos basados en análisis de covarianzas (CBSEM) (AMOS, LISREL, etc.), en cuanto a los objetivos de sus respectivos análisis, en las suposiciones estadísticas en las cuales se basan, y en la naturaleza de los términos estadísticos de ajuste que ofrecen. El abordaje CBSEM busca estimar un conjunto de parámetros del modelo, de tal modo que la matriz de covarianzas teórica determinada por el sistema de ecuaciones estructurales sea tan próxima como sea posible a la matriz de covarianzas empírica, observada en la muestra de estimación. A su vez, PLS-SEM trabaja con bloques de variables (componentes), y estima los parámetros del modelo por medio de la maximización de la varianza explicada de todas las variables dependientes (tanto latentes como observadas) (Roldán y Cepeda, 2019).

Por último, una de las principales ventajas de PLS-SEM sobre CB-SEM es que el primero puede admitir numerosas variables independientes al mismo tiempo, a pesar de que puedan presentar multicolinealidad (Hair, Ringle, y Sarstedt, 2011). El abordaje del PLS-SEM es adecuado para objetivos de pesquisa orientados a la predicción, o sea, es un enfoque causal-predictivo que enfatiza la predicción en la estimación de modelos estadísticos, cuyas estructuras están diseñadas para proporcionar explicaciones causales (Wold, 1982), y esta técnica supera la

aparente dicotomía entre la explicación –como suele subrayarse en la investigación académica – y la predicción, que es la base para desarrollar implicaciones gerenciales (Hair et al., 2019; Roldán y Cepeda, 2019). Además, no requiere normalidad en los datos (Chin y Newsted, 1999).

8.1 Análisis de Modelo de Medida (modelo saturado)

Para producir la investigación alusiva a este primer ensayo se siguió la secuencia de pasos que la literatura consagra en el ámbito de las ecuaciones estructurales (Mackenzie, Podsakoff y Jarvis, 2005), iniciándose el proceso por la especificación del modelo de medida, teniendo en consideración el sentido reflectivo o formativo de las variables indicadoras.

La evaluación del modelo de medida, que analiza si los conceptos teóricos estarán medidos correctamente a través las variables observadas (ítems), posee procedimientos distintos según las variables latentes presenten indicadores en modo reflectivo o formativo. En el primer caso, se evalúan los atributos de validez y fiabilidad en estabilidad y consistencia, mientras que en el segundo se procede al análisis de la multicolinealidad de los indicadores, los pesos de las variables manifiestas y su significación estadística.

Habiendo soporte teórico en cuanto a las variables observadas y su clasificación según grupos (variables latentes), fue nuestro entendimiento que los indicadores son manifestaciones del constructo al cual pertenecen, comparten un tema común de manera que todos y cada uno captan la esencia global del constructo, se espera que sean intercambiables (la supresión de uno de ellos no va a disminuir la representatividad del dominio conceptual del constructo a que pertenecen), y se espera que estén fuertemente correlacionados al compartir una fuente común (el mismo constructo).

Así que consideramos todas las variables latentes del modelo como constructos, no como factores comunes, y cada una de ellas como un factor compuesto (Henseler et al., 2014), y todas sus medidas fueron metodológicamente estimadas en Mode A. De acuerdo con Carmen Felipe y colegas (Felipe et al, 2017), Mode A (correlation weights) es aconsejable cuando se espere encontrar un poder predictivo medio (R^2). Además, la literatura teórica especializada refiere que el Mode A es más adecuado a la estimación de cargas cuando los indicadores manifiestos están correlacionados (Becker, Rai, Ringle, & Völckner, 2013), lo que es el caso. De hecho, al analizar el contenido de las cuestiones involucradas en los grupos teóricos que las conllevan, se estima la existencia de correlación entre ellas, y covarianza, o sea, cuando una pueda variar las demás también podrán variar, en el mismo sentido o no. Por lo tanto, hemos considerado para los constructos del modelo de medida el Mode A, simbolizando que cada constructo refleja esas medidas. Además, estudios similares en los cuales igualmente se buscaba un indicador sintético, se basaron en el abordaje CBSEM a través del recurso al SPSS y AMOS, cuyos indicadores son dibujados como reflectivos. En conclusión, fue especificado el Mode A para todos los constructos del modelo de medida.

8.1.1 Análisis de fiabilidad individual, consistencia interna, validez convergente y validez discriminante

Cuando un constructo es reflectivo, la literatura (Roldán y Cepeda, 2015) determina como etapa inicial la evaluación de la fiabilidad individual del ítem, a través del examen de su carga factorial contributiva para el constructo, y por esa vía se evalúa la comunalidad de esa variable (λ^2), estando bien establecidos los niveles de aceptación. Este proceso de evaluación se denomina usualmente como “depuración de ítems”, ya que se suprimen inicialmente todos los indicadores con cargas factoriales por debajo de 0,4 o negativas. En cuanto a los restantes se mantienen firmes, todos aquellos con cargas iguales o superiores al umbral definido en la literatura ($\lambda \geq 0,707$) (Carmines y Zeller, 1979) y en relación a los que se posicionan entre 0,4 y 0,7, deberá ser adoptada una postura más flexible en etapas iniciales de desarrollo de escalas, o teoría (Hair, Hult, Ringle y Sarstedt, 2014). La supresión de ítems en el intervalo mencionado (0,4 – 0,7) busca mejorar la fiabilidad compuesta del constructo ($\rho_c \geq 0,7$) (Werts, Linn y Jöreskog, 1974), aumentar la validez convergente de sus indicadores supervivientes ($AVE \geq 0,5$) (Fornell y Larcker, 1981) y mejorar la fiabilidad de la respectiva escala (α Cronbach $\geq 0,7$) (Cronbach, 1951).

Se presenta en la página siguiente el modelo inicial de medida.



Figura 18

A continuación, exhibimos la tabla de cargas factoriales (outer loadings) después de la depuración. Las cargas λ de los indicadores por debajo de 0,707 deben, por principio y criterio establecido para depuración, ser evaluadas en cuanto a su mantenimiento o supresión. Sin embargo, deberá hacerse prueba de sentido común en el proceso de eliminación, a fin de no retirar significado al constructo por eliminación intensiva de indicadores, apenas para lograr la mejor marca estadística. La vocación primordial del constructo es medir un fenómeno, y no simplemente generar valores estadísticos elegantes. En vista de los resultados, se procedió a la eliminación obvia de la variable **Q18b_inv_LD** (constr. 01_Changes_12M_G-Home-Work) a efectos de mejoría individual del aporte de los ítems al constructo, habiéndose suprimido igual las variables predictivas **Q100** (constr. 02_Home-work1_G-Home_work), **Q29h_inv_LD** (constr. 03_Risk_exp01_G-Envir_Eq), **Q33_rect_inv** (constr. 07_RisksAware_G-Envir_Eq), **Q40_inv** y **Q43_inv_rect** (constr. 08_Workload_pace_G-Workload_pace), para mejoría de la validez convergente de sus constructos.

Single-item Fiability ($\lambda \geq 0,707$)**OUTER LOADINGS**

	01_Changes_12M_G-Home_Work	02_Home-work1_G-Home_work	03_Risk_exp01_G-Envir_Eq	04_Risk_exp02_G-Envir_Eq	05_Task_efforts1_G-Envir_Eq	06_Task_efforts2_G-Envir_eq	07_RisksAware_G-Envir_Eq	08_Workload_pace_G-Workload_pace	09_WorkCond_G-Control	10_Ddlines_WPace_G-Job_Content	11_WMeaning_G-Job_content	12_Org_relations_G-Org_Culture	13_Chief_relations_G-WorkRelations	14_Present_sit_G- Career_Develop	15_Satisfaction_G-Results_Effects	16_Mind_welfare_G-Results_Effects	17_Sleep_disorders_G-Results_Effects	18_Work_effects1_G-Results_Effects
Q18a_inv_LD	0,759																	
Q18c_inv_LD	0,610																	
Q18d_inv_LD	0,869																	
Q44_rect		0,905																
Q47_rect		0,664																
Q29a_inv_ReplaceMD_1			0,723															
Q29b_inv_ReplaceMD_1			0,779															
Q29c_inv_ReplaceMD_1			0,777															
Q29d_inv_ReplaceMD_1			0,715															
Q29e_inv_ReplaceMD_1			0,724															
Q29f_inv_LD				0,797														
Q29g_inv_LD				0,853														
Q29i_inv				0,757														
Q30f_inv_ReplaceMD_1					0,554													
Q30g_inv_ReplaceMD_1					0,784													
Q30h_inv_ReplaceMD_1					0,898													

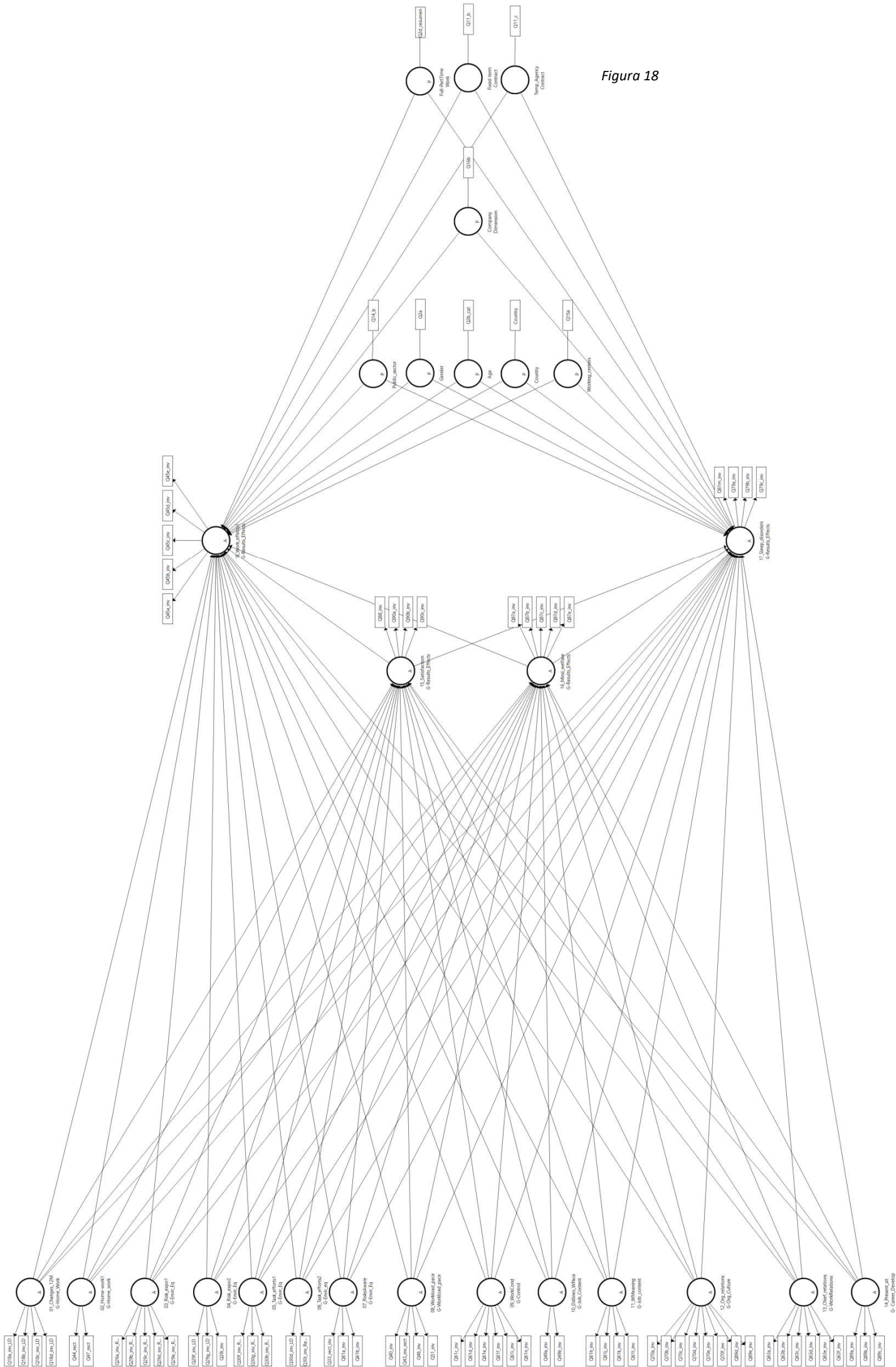
Presentamos estos datos a modo de ejemplo. La tabla completa con la totalidad de los datos se encuentra en la sección final "Sección de Tablas", bajo el título "Tabla 10".

Figura 19 - figura de la tabla 10

Respecto a los análisis de fiabilidad y validez, un comentario deberá ser hecho en cuanto a la jerarquía de importancia de los indicadores. Las dos medidas más relevantes son la Fiabilidad Compuesta (CR) ($\rho_c \geq 0.7$) y la validez convergente (AVE ≥ 0.5). En cuanto al α Cronbach, es conocida su volatilidad, por presentar variaciones notables en función de la cantidad de variables, y una “rule of thumb” es la de atender a su valor a partir de 4 variables por constructo (lo que permitiría la supresión de una para conseguir una lectura igual o superior a 0,7). Así mismo, en la mayoría de las publicaciones actuales no es concedida demasiada importancia a efectos de consistencia interna del constructo, por la importancia indiscutible de la medida de la fiabilidad compuesta (ρ_c).

Después del proceso de supresión, no fue necesario proceder a más eliminaciones de variables, por la que la tabla siguiente aporta los valores finales en cuanto a fiabilidad y validez convergente, cuyos tests miden la fiabilidad de la escala del constructo (consistencia interna) a través del α Cronbach (≥ 0.7), la fiabilidad compuesta (Composite Reliability $\rho_c \geq 0.7$) (Nunnally y Bernstein, 1994), y la validez convergente (AVE ≥ 0.5) (Fornell y Larcker, 1981), la cual representa el porcentaje de varianza del constructo debido a sus indicadores:

	Cronbach's Alpha	rho_A	Composite Reliability $\geq 0,7$	Average Variance Extracted (AVE) $\geq 0,5$
01_Changes_12M_G-Home_Work	0,647	0,697	0,794	0,568
02_Home-work1_G-Home_work	0,440	0,527	0,769	0,630
03_Risk_expo1_G-Envir_Eq	0,802	0,813	0,861	0,554
04_Risk_expo2_G-Envir_Eq	0,723	0,723	0,845	0,645
05_Task_efforts1_G-Envir_Eq	0,682	0,857	0,797	0,576
06_Task_efforts2_G-Envir_eq	0,730	0,999	0,869	0,770
07_RisksAware_G-Envir_Eq	0,559	0,594	0,775	0,541
08_Workload_pace_G-Workload_pace	0,385	0,387	0,764	0,619
09_WorkCond_G-Control	0,798	0,825	0,856	0,503
10_Ddlines_WPace_G-Job_Content	0,787	0,787	0,904	0,824
11_WMeaning_G-Job_content	0,736	0,762	0,831	0,554
12_Org_relations_G-Org_Culture	0,863	0,871	0,893	0,514
13_Chief_relations_G-WorkRelations	0,895	0,898	0,920	0,657
14_Present_sit_G_Career_Develop	0,717	0,753	0,840	0,637
15_Satisfaction_G-Results_Effects	0,737	0,758	0,833	0,558
16_Mind_welfare_G-Results_Effects	0,881	0,890	0,913	0,678
17_Sleep_disorders_G-Results_Effects	0,735	0,735	0,836	0,563
18_Work_effects1_G-Results_Effects	0,766	0,780	0,841	0,516
Age		1,000		
Company_Dimension	1,000	1,000	1,000	1,000
Country		1,000		
Fixed-term_Contract	1,000	1,000	1,000	1,000
Full-PartTime_Work	1,000	1,000	1,000	1,000
Gender		1,000		
Public_sector	1,000	1,000	1,000	1,000
Temp_Agency_Contract	1,000	1,000	1,000	1,000
Working_centers	1,000	1,000	1,000	1,000

Tabla XXXIII

En relación al teste de la validez discriminante, la cual indica en qué medida un determinado constructo es diferente de los otros constructos del modelo, se parte del principio de que ese constructo particular comparte más varianza con sus propias medidas que con los restantes constructos existentes en el mismo modelo. Para medir la validez discriminante la literatura actual presenta tres soluciones:

- El criterio Fornell-Larker, adecuado para gran cantidad de datos;
- Otra se refiere a la presentación de una tabla de correlaciones de scores entre cada constructo y las demás medidas;
- La tercera vía, el test más exacto, trata de sacar el índice HTMT.85 (Heterotrait-monotrait index) (Henseler et al., 2015).

El Fornell-Larker Criterium trata de evidenciar el comportamiento del constructo en cuanto a su varianza media extraída (AVE) y compararlo con la varianza que éste podrá compartir con los restantes. Este criterio es bastante práctico, implicando evaluar si la raíz cuadrada de la varianza compartida entre cada constructo y sus medidas (AVE) supera las correlaciones entre ese mismo constructo y los restantes. El instrumento usado para ello es una de las medidas del SmartPls.

Por otro lado, y según autores (e.g., Henseler, Ringle y Sarstedt, 2016), puesto que el criterio de Fornell-Larcker no es suficientemente sensible, demostrado por estudios de simulación, se recomienda el test HTMT.85, lo más preciso que hay en la actualidad. El teste representa el promedio de las correlaciones heterotrait-heteromethod (correlaciones entre los indicadores que miden el mismo constructo) en relación al promedio de las correlaciones monotrait-heteromethod (correlaciones entre indicadores de constructos distintos que miden fenómenos diferentes (Roldán y Cepeda, 2020). La teoría indica que en un modelo bien ajustado, las correlaciones **heterotrait** deberían ser más pequeñas que las correlaciones **monotrait**, implicando que la ratio HTMT debería estar por debajo de 1. Hay dos umbrales, el primero más restrictivo, de 0,85 (Kline, 2011), y el otro, más relajado, de 0,90.

A su conclusión, se verifica a través de los dos tests concretados (Fornell-Larcker y HTMT), que todos los constructos cumplen el requisito de cualquiera de los dos tests, con confirmación ex-post de los resultados obtenidos, a través de una función condicional del Excel (COUNT.IF). Se presentan a continuación las dos tablas.

EWCS 2015 PROJECT structural model & composite indicator



FORNELL-LARCKER Criterion

0	01_Changes_12M_G-Home_Work	02_Home-work1_G-Home_work	03_Risk_exp01_G-Envir_Eq	04_Risk_exp02_G-Envir_Eq	05_Task_efforts1_G-Envir_Eq	06_Task_efforts2_G-Envir_Eq	07_RisksAware_G-Envir_Eq	08_Workload_pace_G-Workload_pace	09_WorkCond_G-Control	10_Ddlines_WPace_G-Job_Content	11_WMeaning_G-Job_content	12_Org_relations_G-Org_Culture	13_Chief_relations_G-WorkRelations	14_Present_sit_G-Career_Develop	15_Satisfaction_G-Results_Effects	16_Mind_welfare_G-Results_Effects	17_Sleep_disorders_G-Results_Effects	18_Work_effects1_G-Results_Effects	Age	Company_Dimension	Country	Fixed-term_Contract	Full-PartTime_Work	Gender	Public_sector	Temp_Agency_Contract	Working_centers
0	0,753																										
0	0,099	0,793																									
0	0,041	0,175	0,744																								
0	0,046	0,123	0,473	0,803																							
0	0,141	0,200	0,025	0,144	0,759																						
0	0,148	-0,124	-0,304	-0,206	0,166	0,877																					
0	0,005	-0,250	-0,079	-0,046	-0,047	0,091	0,736																				
0	0,280	0,124	0,022	0,048	0,254	0,253	-0,016	0,787																			
0	0,129	-0,287	-0,113	-0,050	0,024	0,248	0,389	0,211	0,709																		
0	0,171	0,223	0,267	0,180	0,175	0,051	-0,072	0,237	-0,057	0,908																	
0	-0,015	-0,261	-0,128	-0,073	-0,103	0,043	0,437	-0,078	0,390	-0,154	0,745																
0	-0,045	-0,308	-0,143	-0,121	-0,153	0,021	0,517	-0,133	0,388	-0,156	0,594	0,717															
0	0,010	-0,252	-0,115	-0,086	-0,085	0,077	0,533	-0,063	0,375	-0,088	0,444	0,644	0,811														
0	0,017	-0,311	-0,169	-0,121	-0,115	0,155	0,404	-0,045	0,427	-0,111	0,399	0,625	0,522	0,798													
0	0,006	-0,353	-0,181	-0,104	-0,092	0,101	0,400	-0,028	0,410	-0,150	0,530	0,573	0,442	0,568	0,747												
0	-0,068	-0,283	-0,114	-0,089	-0,127	0,006	0,302	-0,150	0,247	-0,146	0,388	0,438	0,326	0,387	0,540	0,823											
0	0,149	0,257	0,153	0,144	0,295	0,088	-0,175	0,308	-0,062	0,299	-0,221	-0,307	-0,209	-0,264	-0,314	-0,478	0,750										
0	0,203	0,421	0,175	0,145	0,330	0,090	-0,162	0,382	-0,025	0,327	-0,261	-0,277	-0,178	-0,207	-0,277	-0,348	0,471	0,718									
0	-0,090	-0,073	-0,027	-0,015	-0,050	-0,014	-0,029	-0,034	0,056	-0,098	0,071	-0,006	-0,057	-0,077	0,022	-0,034	0,042	-0,058	n.a.								
0	0,101	0,007	0,016	0,028	0,032	0,193	0,023	0,109	-0,029	0,072	-0,018	-0,109	-0,032	-0,032	-0,023	-0,047	0,103	0,046	0,061	1,000							
0	0,017	0,027	0,055	0,019	0,061	-0,010	0,045	0,010	0,019	0,066	-0,014	0,041	0,048	-0,002	-0,043	0,001	0,023	0,086	-0,058	-0,036	n.a.						
0	-0,028	0,065	0,034	0,008	0,000	-0,091	-0,044	-0,029	-0,100	0,010	-0,036	-0,002	-0,015	-0,040	-0,044	0,006	-0,013	0,005	-0,157	-0,059	0,046	1,000					
0	0,093	0,097	0,106	0,011	0,022	0,065	0,051	0,042	0,042	0,045	-0,023	-0,018	0,011	0,013	-0,024	0,006	-0,019	0,088	-0,016	0,053	0,045	-0,103	1,000				
0	-0,011	-0,012	-0,289	-0,063	0,139	0,076	0,001	0,020	-0,047	-0,035	0,028	0,004	0,011	-0,045	0,033	-0,058	0,096	0,036	0,016	-0,050	-0,032	0,009	-0,215	n.a.			
0	0,031	-0,042	-0,095	0,017	0,162	0,075	0,056	0,078	0,045	-0,113	0,072	-0,003	0,023	-0,006	0,060	-0,002	0,044	-0,001	0,141	0,208	0,032	-0,020	0,026	0,122	1,000		
0	-0,021	0,011	0,038	0,021	-0,032	-0,054	-0,038	-0,031	-0,061	0,014	-0,020	-0,017	-0,026	-0,026	-0,024	-0,002	0,002	-0,011	-0,045	-0,002	-0,004	-0,043	-0,074	-0,010	-0,024	1,000	
0	0,077	-0,004	-0,023	-0,011	0,045	0,149	0,004	0,101	0,016	0,037	-0,022	-0,068	-0,031	-0,012	-0,012	-0,031	0,079	0,042	0,017	0,530	-0,046	-0,020	-0,005	-0,027	0,050	0,011	1,000

Amount of values/column surpassing diagonal values

Tabla XXXIV

8.2 Análisis del modelo estimado (multidimensional y modelo estructural)

Se presenta el modelo estimado resultante:



Figura 20

En el modelo estimado, con sus cargas y pesos (outer loadings λ ; outer weights γ), existen dos singularidades en sus valores, las cuales comentaremos a continuación.

Hay dos constructos Mode B que presentan indicadores cuyo peso (γ) tienen señal negativa, a saber:

- **02_G-Envir_Eq:** variable **07_RisksAware_G-Envir_Eq** (- 0,677)
- **05_G-Job_content:** variable **10_DdLines_WPace_G-Job_Content** (- 0,409)

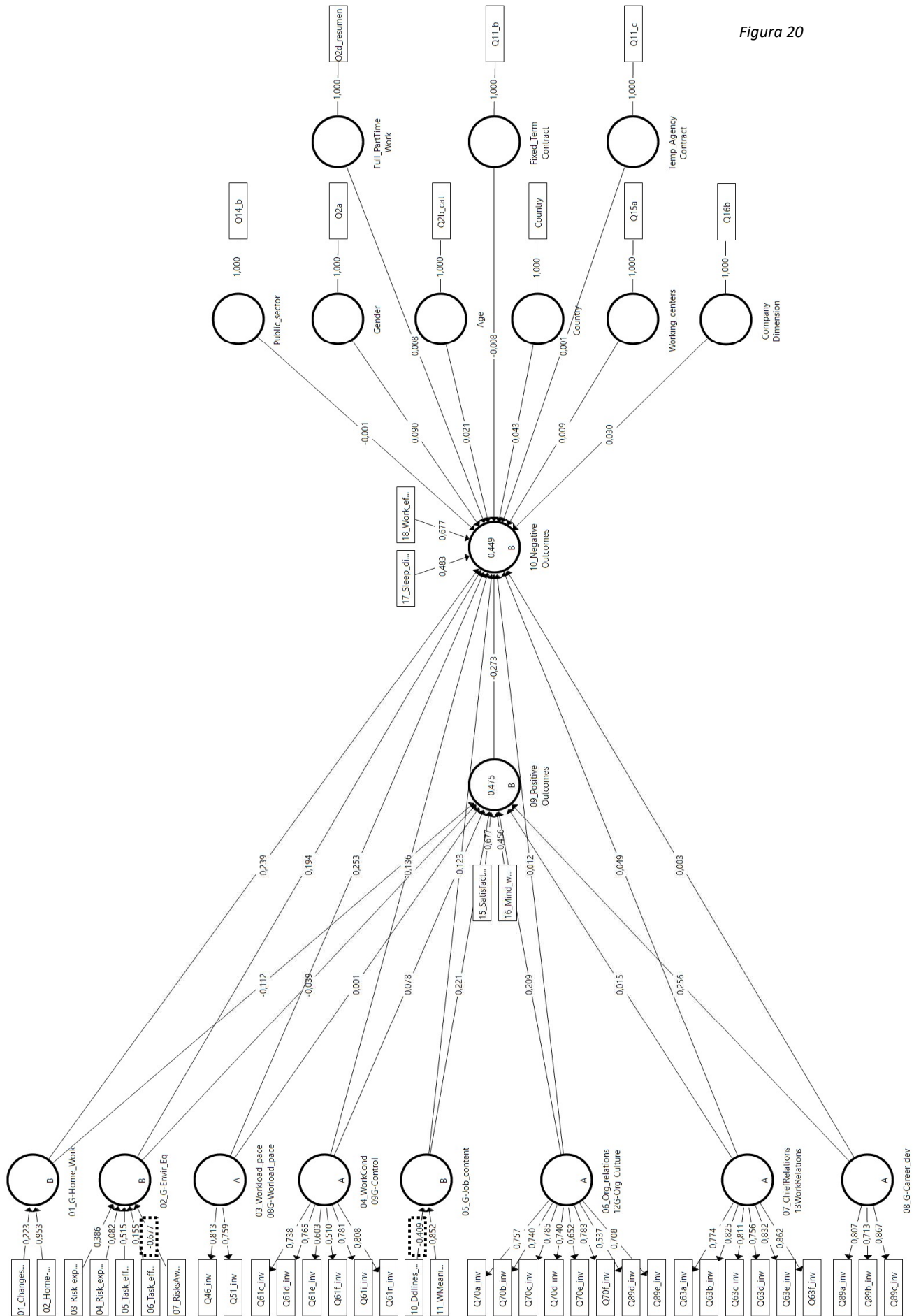
El hecho sorprendió al inicio, pero después de analizar todas las cuestiones asociadas a cada indicador, o sea, revisitando el modelo de medida final y después de una lectura atenta a los textos se concluye, sin margen para dudas, que cada una de las dos variables antes mencionadas, las cuales son por sí mismo constructos de primera orden, van en dirección opuesta a las otras variables a que se asocian en el constructo respectivo.

Así, a ejemplo, la variable componente **07_RisksAware_G-Envir_Eq** (constructo 02_G-Envir_Eq) reproduce los efectos de tres variables predictivas (Q33_rect_inv; Q61a_inv; Q61b_inv) cuyos textos se refieren a “Estar informado en cuanto a los riesgos para la salud y la seguridad relacionados con el desempeño del trabajo”; a “Recibir ayuda y apoyo de sus compañeros de trabajo”; “Recibir ayuda y apoyo de su chef”. De hecho, son temas neutros o con positividad.

Por otro lado, la variable **03_Risk_expo1_G-Envir_Eq** que pertenece al mismo constructo de la variable componente anterior, reproduce los efectos de 5 variables predictivas (Q29a_inv_ReplaceMD_1 hasta Q29e_inv_ReplaceMD_1), cuyos textos se refieren a la exposición del trabajador en cuanto a: “vibraciones producidas por herramientas manuales, máquinas, etc.”; “Ruidos tan fuertes que tiene que levantar la voz...”; “Temperaturas altas que le hacen sudar...”; “Temperaturas bajas ...”; y “Respirar humos o gases (de soldadura o de salida de humos, ...), polvo ...”, o sea, se trata de temas cuyo impacto en la persona es de manifiesta negatividad. Lo mismo sucede con los textos de las cuestiones (variables predictivas) que componen las demás variables (tres más) latentes del constructo 02_G-Envir_Eq.

Por lo tanto, habrá que expurgar el componente **07_RisksAware_G-Envir_Eq** de su constructo latente de segunda orden (02_G-Envir_Eq), quedándose en su forma anterior de latente de primera orden, la del modelo de medida.

También procedemos de forma equivalente con el compuesto **10_DdLines_WPace_G-Job_Content**, pero al haber tan solo dos componentes en el constructo 05_G-Job_content, el otro componente (**11_WorkMeaning_G-Job_content**) se queda en su configuración anterior, como compuesto de primera orden.

A continuación, presentamos el modelo global final (modelo estimado) en la página siguiente, después de las rectificaciones producidas en el transcurso de las aclaraciones anteriores.

Figura 21

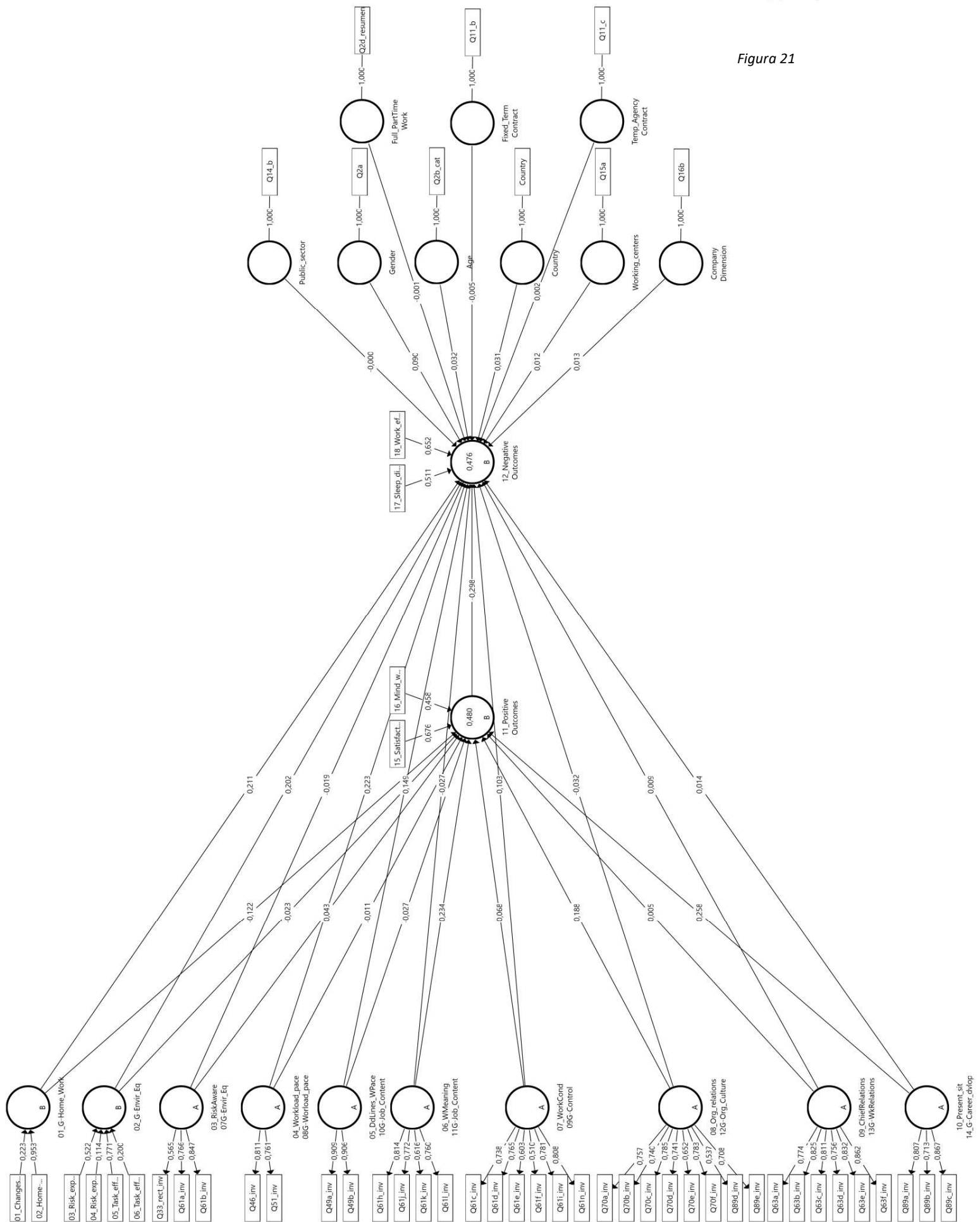

Para poder identificarse con mayor facilidad las variables manifiestas y su pertenencia al respectivo grupo, presentamos el cuadro abajo que es una síntesis asociando la identificación (código) de las cuestiones a los respectivos grupos de variables latentes de primera orden.

Compounds		First-order construction composition variables		Control variables	
01_G-Home_Work	01_Changes_12M_G-Home_Work ¹	02_Home-work1_G-Home_work ¹	Q18a_inv_ID	Q18d_inv_ID	Country
02_G-Envir_Eq	03_Risk_expo1_G-Envir_Eq ¹	04_Risks_expo2_G-Envir_Eq ¹	Q44_rect	Q47_rect	Company Dimension
03_RisksAware_07G-Envir_Eq	Q33_rect_inv	Q61a_inv	Q29a_inv_ReplaceMD_1	Q29b_inv_ReplaceMD_1	Gender
04_Workload_pace_08G-Workload_pace	Q46_inv	Q51_inv	Q29f_inv_ReplaceMD_1	Q29g_inv_ReplaceMD_1	Age
05_DLines_WPace_10G-Job_Content	Q49a_inv	Q49b_inv	Q30f_inv_ReplaceMD_1	Q30g_inv_ReplaceMD_1	Full-PartTime Work
06_WMeaning_11G-Job_Content	Q61h_inv	Q61i_inv	Q30d_inv_ID	Q30i_inv_ReplaceMD_1	Fixed-term Contract
07_WorkCond_09G-Control	Q61c_inv	Q61d_inv	Q88_inv	Q90a_inv	Temp_Agency Contract
08_Org_relations_12G-Org_Culture	Q70a_inv	Q70b_inv	Q87a_inv	Q87b_inv	Public_sector
09_ChiefRelations_13G-WkRelations	Q63a_inv	Q63b_inv	Q61m_inv	Q79a_inv	Working_centers
10_Present_sit_14G-Career_dviop	Q89a_inv	Q89b_inv	Q45a_inv	Q45b_inv	
11_Positive Outcomes	15_Satisfaction_G-Results_Effects ¹	16_Mind_welfare_G-Results_Effects ¹			
12_Negative Outcomes	17_Sleep_disorders_G-Results_Effects ¹	18_Work_effects1_G-Results_Effects ¹			
01_Changes_12M_G-Home_Work	Q18a_inv_ID	Q18c_inv_ID	Q18d_inv_ID		
02_Home-work1_G-Home_work	Q44_rect	Q47_rect			
03_Risk_expo1_G-Envir_Eq	Q29a_inv_ReplaceMD_1	Q29b_inv_ReplaceMD_1	Q29c_inv_ReplaceMD_1	Q29d_inv_ReplaceMD_1	Q29e_inv_ReplaceMD_1
04_Risks_expo2_G-Envir_Eq	Q29f_inv_ReplaceMD_1	Q29g_inv_ReplaceMD_1	Q29i_inv		Q29h_inv_ID
05_Task_efforts1_G-Envir_Eq	Q30f_inv_ReplaceMD_1	Q30g_inv_ReplaceMD_1	Q30h_inv_ReplaceMD_1		
06_Task_efforts2_G-Envir_Eq	Q30d_inv_ID	Q30i_inv_ReplaceMD_1			
15_Satisfaction_G-Results_Effects	Q88_inv	Q90a_inv	Q90b_inv	Q90c_inv	
16_Mind_welfare_G-Results_Effects	Q87a_inv	Q87b_inv	Q87c_inv	Q87d_inv	Q87e_inv
17_Sleep_disorders_G-Results_Effects	Q61m_inv	Q79a_inv	Q79b_inv	Q79c_inv	
18_Work_effects1_G-Results_Effects	Q45a_inv	Q45b_inv	Q45c_inv	Q45d_inv	Q45e_inv

Tabla XXXVI

Tabla XXXVII

Un chequeo de rutina en cuanto a colinealidad que podría existir en el modelo estimado antes presentado (que ya está corregido del problema de multicolinealidad detectado), permitió identificar cinco variables con valores que exceden el límite del VIF de 3,3. Las variables en cuestión son todas de control del modelo, a saber, **Indefinitive_Contract**, **Fixed-term:Contrat**, **Private_Sector**, **Public_Sector**, y **Temp_Agency_Contract**, constatable por la tabla abajo:

	VIF	
	11_Positive Outcomes	12_Negative Outcomes
01_G-Home_Work	1,260	1,315
02_G-Envir_Eq	1,214	1,245
03_RiskAware_07G-Envir_Eq	1,603	1,628
04_Workload_pace_08G-Worload_pace	1,232	1,257
05_DdLines_WPace_10G-Job_Content	1,178	1,224
06_WMmeaning_11G-Job_Content	1,677	1,807
07_WorkCond_09G-Control	1,534	1,581
08_Org_relations_12G-Org_Culture	2,651	2,779
09_ChiefRelations_13G-WkRelations	1,957	1,969
10_Present_sit_14_G-Career_dvelop	1,829	1,992
11_Positive_Outcomes		1,929
12_Negative_Outcomes	-	-
Age		1,115
Company_Dimension		1,524
Country		1,031
Fixed_Term_Contract		22,762
Full_PartTime_Work		1,103
Gender		1,087
Indefinitive_contract		24,888
Private_sector		4,484
Public_sector		4,408
Temp_Agency_Contract		3,569
Working_centers		1,410

Tabla XXXVIII

Para eliminar los más que potenciales problemas decurrentes de multicolinealidad, producimos un análisis avanzado de multicolinealidad, a través del programa SPSS. A ese efecto, reproducimos con exactitud total el modelo estructural en SPSS, buscando colinealidad.

Coefficients^a

Model		Unstandardized Coefficients		Standardized Coefficients	t	Sig.	Collinearity Statistics	
		B	Std. Error	Beta			Tolerance	VIF
1	(Constant)	5,246E-6	,004		,001	,999		
	01_G-Home_Work	,211	,005	,211	44,193	,000	,760	1,315
	02_G-Envir_Eq	,202	,005	,202	43,525	,000	,803	1,245
	03_RiskAware_07G-Envir_Eq	-,019	,005	-,019	-3,541	,000	,614	1,628
	04_Workload_pace_08G-Worload_pace	,223	,005	,223	47,896	,000	,795	1,257
	05_DdLines_WPace_10G-Job_Content	,149	,005	,149	32,308	,000	,817	1,224
	06_WMeaning_11G-Job_Content	-,027	,006	-,027	-4,812	,000	,553	1,807
	07_WorkCond_09G-Control	,103	,005	,103	19,733	,000	,632	1,581
	08_Org_relations_12G-Org_Culture	-,032	,007	-,032	-4,665	,000	,360	2,779
	09_ChiefRelations_13G-WkRelations	,009	,006	,009	1,515	,130	,508	1,969
	10_Present_sit_14_G-Career_dvlop	,014	,006	,014	2,468	,014	,502	1,992
	11_Positive_Outcomes	-,298	,006	-,298	-51,646	,000	,518	1,929
	Age	,031	,004	,031	7,115	,000	,897	1,115
	Company_Dimension	,013	,005	,013	2,555	,011	,656	1,524
	Country	,031	,004	,031	7,343	,000	,970	1,031
	Fixed_Term_Contract	,022	,020	,022	1,116	,264	,044	22,762
	Full_PartTime_Work	-,001	,004	-,001	-,296	,767	,907	1,103
	Gender	,090	,004	,090	20,674	,000	,920	1,087
	Indefinitive_contract	,029	,021	,029	1,399	,162	,040	24,888
	Private_sector	,010	,009	,010	1,102	,270	,223	4,484
	Public_sector	,008	,009	,008	,925	,355	,227	4,408
	Temp_Agency_Contract	,012	,008	,012	1,471	,141	,280	3,569
	Working_centers	,012	,005	,012	2,480	,013	,709	1,410

a. Dependent Variable: 12_Negative_Outcomes

Tabla XXXIX

Citando a Roldán y Cepeda Carrión (2020), “... Belsley (1991) propone usar conjuntamente los *índices de condición* y la *proporción de descomposición de varianza* para realizar el diagnóstico de colinealidad (SPSS), usando como umbral de proporción alta 0,5 ...”, en conjunción con una magnitud de índices de condición mayores que 30.

El máximo valor del índice de condición encontrado fue de 14,449 pero, la proporción de descomposición de varianza encontrada para **Indefinitive_Contract** y **Fixed-term_Contract** fue de 0,99, o sea, el máximo valor. Igualmente detectamos para **Private_Sector** y **Public_Sector** el valor de 0,93, y de 0,74 para **Temp_Agency_Contract**.

El proceso de eliminación deberá iniciarse por la variable con mayor VIF, que es **Indefinitive_Contract** (24,888). Revisando el texto de las cuestiones que los tipos de contrato señalados conllevan, y al confirmar el instrumento de medición que es de tipo dicotómico, se concluyó que las dos variables son en realidad dos ítems redundantes cuando en **Fixed-term_Contract** el valor es cero, porque obviamente eso significa que el contrato será de tipo indefinido, esto si el contrato temporario de agencia es igualmente cero. Retirando la respectiva variable, el resultado se normalizó en cuanto al VIF para los otros dos tipos de contrato, quedando por solucionar los sectores privado y público. En cuanto a estos dos casos, procedemos de forma idéntica eliminando la variable **Private_Sector**, lo que estabilizó integralmente los VIF, como es demostrable por la tabla siguiente.

Coefficients^a

Model	Unstandardized Coefficients		Standardized Coefficients	t	Sig.	Collinearity Statistics	
	B	Std. Error	Beta			Tolerance	VIF
1 (Constant)	2,442E-5	,004		,006	,995		
01_G-Home_Work	,211	,005	,211	44,199	,000	,760	1,315
02_G-Envir_Eq	,202	,005	,202	43,519	,000	,805	1,243
03_RiskAware_07G-Envir_Eq	-,019	,005	-,019	-3,520	,000	,614	1,628
04_Workload_pace_08G-Worload_pace	,223	,005	,223	47,900	,000	,797	1,255
05_DdLines_WPace_10G-Job_Content	,149	,005	,149	32,487	,000	,821	1,218
06_WMeaning_11G-Job_Content	-,027	,006	-,027	-4,845	,000	,554	1,806
07_WorkCond_09G-Control	,103	,005	,103	19,755	,000	,633	1,580
08_Org_relations_12G-Org_Culture	-,032	,007	-,032	-4,667	,000	,360	2,779
09_ChiefRelations_13G-WkRelations	,009	,006	,009	1,506	,132	,508	1,969
10_Present_sit_14_G-Career_dvlop	,014	,006	,014	2,439	,015	,502	1,991
11_Positive_Outcomes	-,298	,006	-,298	-51,656	,000	,518	1,929
Age	,032	,004	,032	7,257	,000	,909	1,100
Company_Dimension	,013	,005	,013	2,487	,013	,661	1,512
Country	,031	,004	,031	7,355	,000	,971	1,030
Fixed_Term_Contract	-,005	,004	-,005	-1,170	,242	,944	1,059
Full_PartTime_Work	-,001	,004	-,001	-,200	,842	,909	1,100
Gender	,090	,004	,090	20,675	,000	,922	1,084
Public_sector	,000	,004	,000	-,056	,956	,875	1,143
Temp_Agency_Contract	,002	,004	,002	,542	,588	,983	1,017
Working_centers	,012	,005	,012	2,460	,014	,709	1,410

a. Dependent Variable: 12_Negative_Outcomes

Tabla XLI

8.2.1 Hipótesis de pesquisa

Este estudio en el cual intervenimos está basado en datos secundarios, provenientes de recogidas concretadas por encuestas ejecutadas en 2015 (EWCS-EACT-ESENER). Con ello, se pretende la construcción de un “indicador sintético” que mida los impactos de los riesgos psicosociales en el trabajador, y compare los mismos impactos por países-regiones y sectores de actividad.

Un indicador sintético consiste en un “Composite”, o sea, un compuesto, creado a partir de variables independientes que actúan, directa e indirectamente sobre un resultado (“Outcomes Variables’ set”), o compuesto dependiente, midiéndose los efectos de las predictivas sobre las

que componen el resultado. Su aplicación como guía para orientar políticas públicas será su función primera.

El modelo teórico que se nos han indicado es, en su general, el modelo de Cox (Cox, 1993; Cox & Griffiths, 2005), a su vez basado en las definiciones de International Labour Organization (ILO, 1986) en cuanto a los factores a considerar que miden los riesgos psicosociales.

La configuración que se nos propuso para el modelo teórico conlleva un conjunto de factores de riesgo psicosocial (basados en las cuestiones que se nos han previamente indicado cómo las utilizables a efectos del estudio), los cuales provocan un resultado (Resultados y Efectos, según el soporte teórico proveído en Excel), o sea, se considera un conjunto de regresiones, a partir de esos grupos en dirección a los Resultados y Efectos. A continuación, presentamos el modelo teórico e hipótesis que el mismo conlleva:



Figura 22

En lo que se refiere a Resultados y Efectos, al considerarse el contenido de las cuestiones utilizadas (variables de escala) y el modelo de medida, son identificables dos grandes grupos en términos de variables latentes dependientes de segunda orden.

El primero hace resumen de los efectos positivos producidos, conllevando **15_Satisfaction_G-Results_Effects** y **16_Mind_welfare_G-Results_Effects** como variables latentes y a la vez componentes del compuesto de segunda orden **11_Positive_Outcomes**. Las dos resumen características y estados sentidos resultantes, positivos, habiendo expectativa de que los constructos antecedentes presenten regresiones con significancia.

El segundo hace resumen de los efectos negativos producidos, conllevando las variables latentes **17_Sleep_disorders_G-Results_Effects** y **18_Work_effects1_G-Results_Effects**, las cuales son componentes del compuesto de segunda orden **12_Negative_Outcomes**.

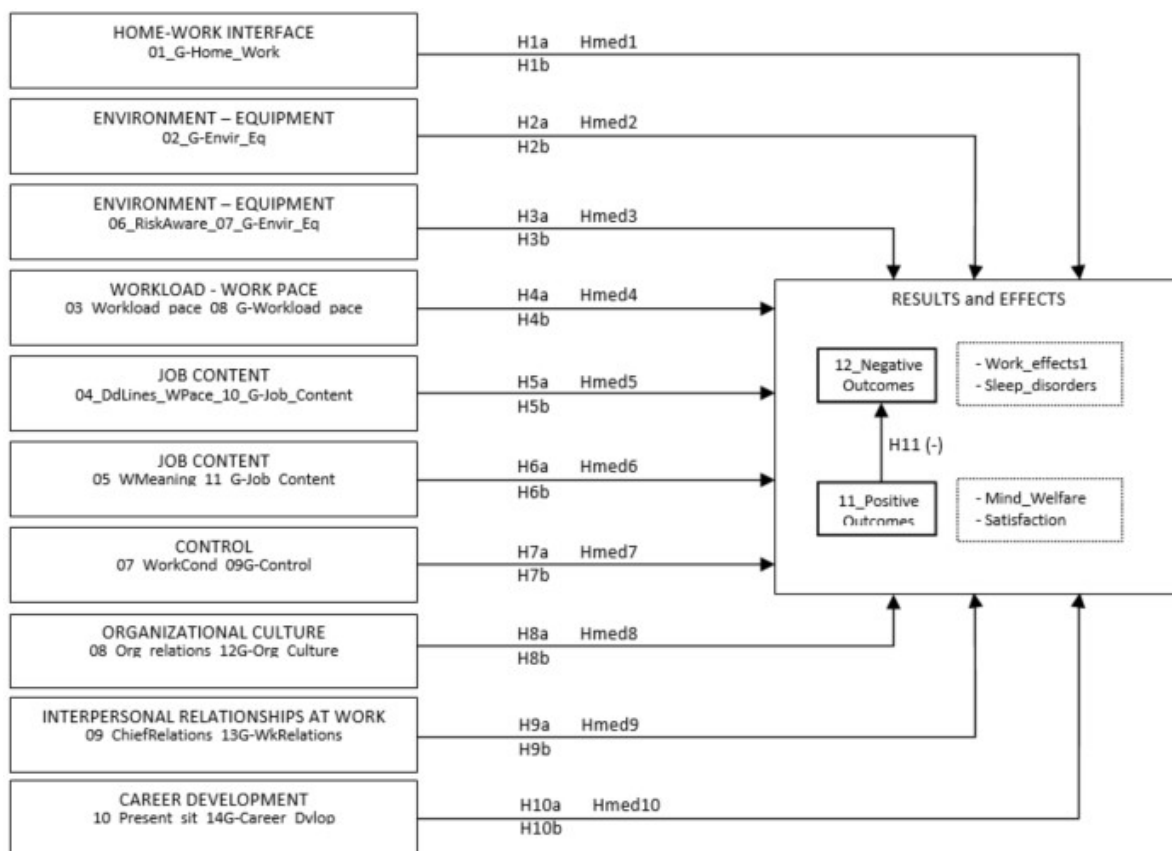
Nuestra expectativa es que las variables predictivas, a representar riesgos para el trabajador, actúen con significancia en los dos compuestos.

Igualmente, y por tradición en este género de estudios, aunque los dos compuestos finales 11 y 12 sean resultados, el concepto prevaleciente es medir los efectos negativos resultantes. Por ese motivo, hicimos una regresión [H11 (-)] entre los dos, para medir significancia de efectos negativos de los resultados positivos (11) en los resultados negativos (12), por lo que el compuesto endógeno final es el 12.

Por último, las hipótesis que llevan letra “a” respectan a regresiones desde el compuesto **11_Positive_Outcomes**, y las que poseen letra “b” corresponden a regresiones a partir del compuesto **12_Negative_Outcomes**. Las hipótesis que presentan la letra “m” están asociadas a efectos indirectos por mediación, por vía del compuesto **11_Positive_Outcomes** como mediador, sobre la variable dependiente final **12_Negative_Outcomes**.

A completar nuestras hipótesis de pesquisa, consideramos efectos de mediación, de los compuestos predictivos sobre el compuesto 12, por vía del compuesto mediador 11. Sigue un cuadro con las 31 declaraciones:

Hipotesis	Declaración
1 H1a	La variable 01_G-Home_Work está relacionada con 11_Positive_Outcomes
2 H1b	La variable 01_G-Home_Work está relacionada con 12_Negative_Outcomes
3 H2a	La variable 02_G-Envir_Eq está relacionada con 11_Positive_Outcomes
4 H2b	La variable 02_G-Envir_Eq está relacionada con 12_Negative_Outcomes
5 H3a	La variable 06_RiskAware_07G-Envir_Eq está relacionada con 11_Positive_Outcomes
6 H3b	La variable 06_RiskAware_07G-Envir_Eq está relacionada con 12_Negative_Outcomes
7 H4a	La variable 03_Workload_pace_08G-Workload_pace está relacionada con 11_Positive_Outcomes
8 H4b	La variable 03_Workload_pace_08G-Workload_pace está relacionada con 12_Negative_Outcomes
9 H5a	La variable 04_DdLines_Wpace_10G-Job_Content está relacionada con 11_Positive_Outcomes
10 H5b	La variable 04_DdLines_Wpace_10G-Job_Content está relacionada con 12_Negative_Outcomes
11 H6a	La variable 05_Wmeaning_11G-Job_Content está relacionada con 11_Positive_Outcomes
12 H6b	La variable 05_Wmeaning_11G-Job_Content está relacionada con 12_Negative_Outcomes
13 H7a	La variable 07_WorkCond_09G-Control está relacionada con 11_Positive_Outcomes
14 H7b	La variable 07_WorkCond_09G-Control está relacionada con 12_Negative_Outcomes
15 H8a	La variable 08_Org_relations_12G-Org_Culture está relacionada con 11_Positive_Outcomes
16 H8b	La variable 08_Org_relations_12G-Org_Culture está relacionada con 12_Negative_Outcomes
17 H9a	La variable 09_ChiefRelations_13G-WkRelations está relacionada con 11_Positive_Outcomes
18 H9b	La variable 09_ChiefRelations_13G-WkRelations está relacionada con 12_Negative_Outcomes
19 H10a	La variable 10_Present_sit_14G-Career_Dvlop está relacionada con 11_Positive_Outcomes
20 H10b	La variable 10_Present_sit_14G-Career_Dvlop está relacionada con 12_Negative_Outcomes
21 H11	La variable 11_Positive_Outcomes está relacionada negativamente con 12_Negative_Outcomes
22 Hmed1	La variable 01_G-Home_Work produce efectos indirectos en 12_Negative_Outcomes , a través de 11_Positive_Outcomes
23 Hmed2	La variable 02_G-Envir_Eq produce efectos indirectos en 12_Negative_Outcomes , a través de 11_Positive_Outcomes
24 Hmed3	La variable 06_RiskAware_07G-Envir_Eq produce efectos indirectos en 12_Negative_Outcomes , a través de 11_Positive_Outcomes
25 Hmed4	La variable 03_Workload_pace_08G-Workload_pace produce efectos indirectos en 12_Negative_Outcomes , a través de 11_Positive_Outcomes
26 Hmed5	La variable 04_DdLines_Wpace_10G-Job_Content produce efectos indirectos en 12_Negative_Outcomes , a través de 11_Positive_Outcomes
27 Hmed6	La variable 05_Wmeaning_11G-Job_Content produce efectos indirectos en 12_Negative_Outcomes , a través de 11_Positive_Outcomes
28 Hmed7	La variable 07_WorkCond_09G-Control produce efectos indirectos en 12_Negative_Outcomes , a través de 11_Positive_Outcomes
29 Hmed8	La variable 08_Org_relations_12G-Org_Culture produce efectos indirectos en 12_Negative_Outcomes , a través de 11_Positive_Outcomes
30 Hmed9	La variable 09_ChiefRelations_13G-WkRelations produce efectos indirectos en 12_Negative_Outcomes , a través de 11_Positive_Outcomes
31 Hmed10	La variable 10_Present_sit_14G-Career_Dvlop produce efectos indirectos en 12_Negative_Outcomes , a través de 11_Positive_Outcomes

Tabla XLII

8.2.2 Análisis del modelo especificado (modelo de medida multidimensional)

Partiendo de la base de datos de trabajo utilizada hasta aquí, formamos una nueva base de datos con los scores de todos los constructos. Esa nueva base de datos (EWCS_2015_DATA_PLS15_05_2020_Antonio) permite tratar la multidimensionalidad en el modelo final.

En esta fase se ejecuta la valoración de los constructos del modelo de medida. Los constructos en Mode A ya fueron analizados en el modelo saturado inicial. Así que pasaremos a concretar la

valoración de los constructos en Mode B. Ese análisis se compone de cuatro criterios cuyos resultados deberán encuadrarse con los siguientes límites:

- Validez externa o convergente – correlación entre la variable latente medida formativamente y reflectivamente deberá igualar o exceder un umbral: $\geq 0,8$ (Chin, 2010), $\geq 0,7$ (Hair et al., 2017)
- Valoración de la multicolinealidad – Factor de inflación de la varianza $VIF \leq 3$
- Valoración de la relevancia (magnitud) de los pesos: $\leq 1/\sqrt{n}$
- Valoración de la significación de los pesos: Bootstrapping de 5000 remuestros, con test de 2 colas y $pvalue < 0,05$

8.2.2.1 Validez convergente

Para analizar la validez externa o convergente, se utiliza un modelo de redundancia de dos bloques (Mathieson, Peacock y Chin, 2001). El constructo formativo objeto de análisis asume causalidad para un constructo semejante pero reflectivo y previamente validado. Las variables del constructo reflectivo son las variables predictivas de cada uno de los componentes del constructo formativo, existiendo en la literatura una solución alternativa, por la cual los indicadores del constructo formativo podrán ser sustituidos por el “score” formativo resultante (Hair et al., 2014). La configuración del modelo redundante es presentada a continuación:

Figura 23

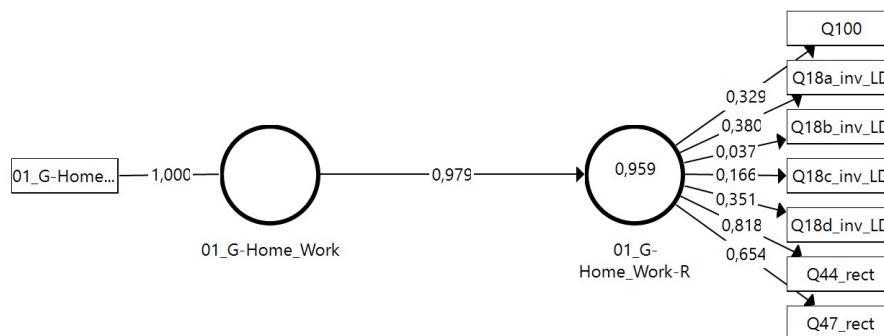

Del proceso de depuración resultó el modelo siguiente:

Figura 24

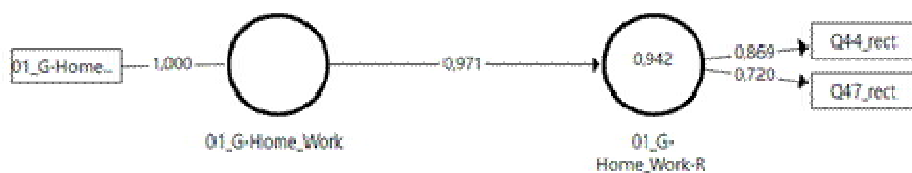

Los parámetros a cumplir para el constructo reflectivo son los mismos ya conocidos y aplicados, o sea, cargas individuales de indicadores superiores con estándar igual o superior a $\lambda \geq 0,707$, fiabilidad compuesta $\rho_c \geq 0,7$, y validez convergente igual o superior a $AVE \geq 0,5$.

	Loadings	Path coefficient $\geq 0,8$	α Cronbach	rho_A	Composite Reliability $\geq 0,7$	Average Variance Extracted (AVE) $\geq 0,5$
01_G-Home_Work-R		0,971	0,440	0,471	0,776	0,637
Q44_rect	0,869					
Q47_rect	0,720					

Tabla XLIII

El procedimiento fue repetido para otros tres constructos, cuyos resultados de sus análisis se presentan a continuación:

Figura 25

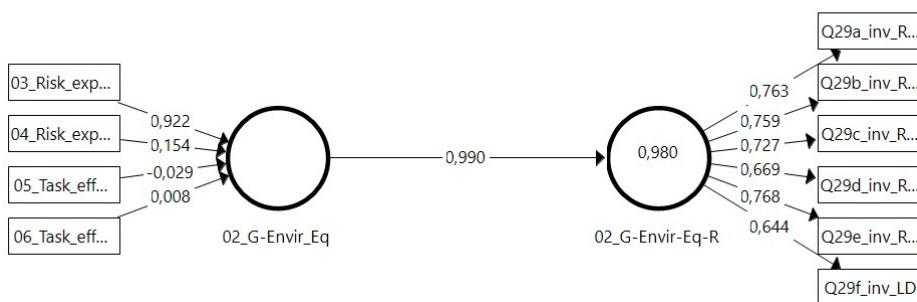

	Loadings	Path coefficient $\geq 0,8$	α Cronbach	rho_A	Composite Reliability $\geq 0,7$	Average Variance Extracted (AVE) $\geq 0,5$
02_G-Envir-Eq-R		0,990	0,816	0,821	0,868	0,523
Q29a_inv_ReplaceMD1	0,763					
Q29b_inv_ReplaceMD1	0,759					
Q29c_inv_ReplaceMD1	0,727					
Q29d_inv_ReplaceMD1	0,669					
Q29e_inv_ReplaceMD1	0,768					
Q29f_inv_LD	0,644					

Tabla XLIV

Figura 26

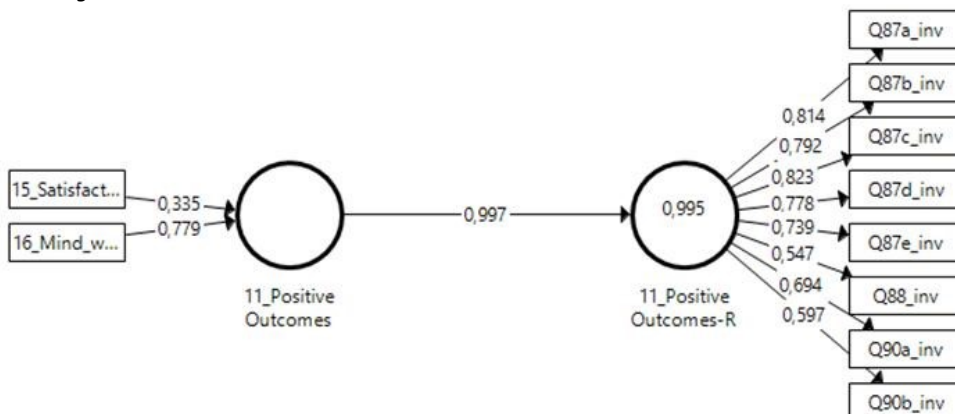

	Loadings	Path coefficient ≥ 0,8	α Cronbach	rho_A	Composite Reliability ≥ 0,7	Average Variance Extracted (AVE) ≥ 0,5
11_Positive Outcomes			0,997	0,871	0,883	0,899
Q87a_inv	0,814					
Q87a_inv	0,792					
Q87a_inv	0,823					
Q87a_inv	0,778					
Q87a_inv	0,739					
Q88_inv	0,547					
Q90a_inv	0,694					
Q90b_inv	0,597					

Tabla XLV



Figura 27

	Loadings	Path coefficient ≥ 0,8	α Cronbach	rho_A	Composite Reliability ≥ 0,7	Average Variance Extracted (AVE) ≥ 0,5
12_Negative Outcomes			0,919	0,754	0,753	0,835
Q45b_inv	0,679					
Q45c_inv	0,648					
Q79a_inv	0,715					
Q79b_inv	0,709					
Q79c_inv	0,792					

Tabla XLVI

8.2.2.2 Evaluación de multicolinealidad potencial entre indicadores (VIF) (modelo externo, o de medida)

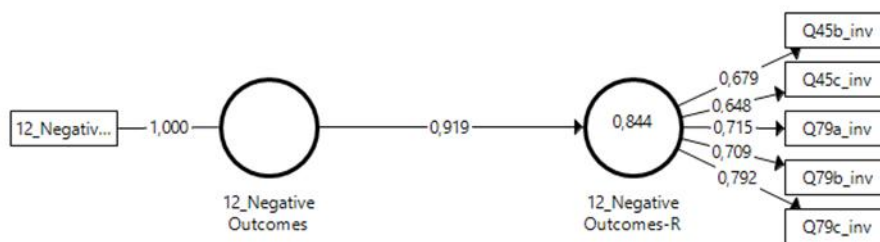
El paso siguiente fue de evaluar la multicolinealidad que pueda existir en el modelo de medida. El test es proporcionado por el programa SmartPLS, y no fue detectado ningún valor del VIF arriba de 3, como queda demostrado en la figura siguiente:

Outer Model	VIF
01_Changes_12M_G-Home_Work	1,010
02_Home-work1_G-Home_work	1,010
03_Risk_expo1_G-Envir_Eq	1,366
04_Risk_expo2_G-Envir_Eq	1,332
05_Task_efforts1_G-Envir_Eq	1,065
06_Task_efforts2_G-Envir_eq	1,152
15_Satisfaction_G-Results_Effects	1,412
16_Mind_welfare_G-Results_Effects	1,412
17_Sleep_disorders_G-Results_Effects	1,285
18_Work_effects1_G-Results_Effects	1,285

Tabla XLVII

8.2.2.3 Valoración y relevancia de los pesos (weights)

Este test trata de indicar la valoración máxima que un indicador (variable) deberá poseer en la estructura de composición de cada variable latente. El máximo valor alcanzable para un *weight* de un conjunto de indicadores formativos (no correlacionado) de un constructo es $1/n^{1/2}$, siendo “n” el número de indicadores. A medida que aumenta el número “n”, disminuye el valor medio de los pesos y mayor la probabilidad de encontrarnos con pesos no significativos. Del test resultó que hay en el primer constructo un valor excesivo de **02_Home-work1_G-Home_work**, así como en el segundo constructo del peso de **05_Task_efforts1_G-Envir_Eq**. De momento no iremos tomar ninguna decisión en cuanto a manutención o agregación a nivel superior, del primer constructo, ya que no hay multicolinealidad y queda el test de valoración de la significación de los pesos.

8.2.2.4 Valoración de la significación de los pesos por Bootstrapping

Para este procedimiento, realizamos un test de *bootstrap* con configuración de acuerdo con la literatura, i.e., mínimo de 5.000 muestras bootstrap, sin cambios de signo (no sign changes) que es la opción más conservadora, 2 colas y nivel de significación $p_{value} < 0,05$.

Los resultados finales están presentados en su tabla debida más abajo. En ellos, se proporciona también los intervalos de confianza basados en bootstrap, con sesgo corregido. Según Hair et al. (2017), el método percentil tiene una limitación, por la cual hace suposición de que el valor esperado de un determinado parámetro resultado de calcular su valor medio en todas las muestras bootstrap, es una estimación no sesgada del valor verdadero. Sin embargo, esta suposición no tiene por qué cumplirse necesariamente, a ejemplo cuando la distribución del parámetro es asimétrica, por lo que el método del percentil está sujeto al error de cobertura (e.g., un intervalo de confianza del 95% puede ser en realidad del 90%). Para solucionarlo, los investigadores han introducido correcciones de sesgo, y una de las opciones más destacadas del conjunto de enfoques viene dada por los intervalos de confianza basados en bootstrap con sesgo corregido y acelerado (bias-corrected and accelerated – Bca), los cuales ajustan los sesgos y la asimetría en la distribución de bootstrap (Hair et al., 2017; Sarstedt, Henseler y Ringle, 2011; Gudergan et al., 2008), opción esa considerada en el test.

	Original Sample (O)	Sample Mean (M)	Standard Deviation (STDEV)	T Statistics (O/STDEV)	P Values	Confidence intervals bias-corrected			Significant (p<0,05)
						Bias	2.5%	97.5%	
01_Changes_12M_G-Home_Work -> 01_G-Home_Work	0,223 ***	0,223	0,012	18,903	0,000	0,000	0,200	0,247	Yes
02_Home-work1_G-Home_work -> 01_G-Home_Work	0,953 ***	0,953	0,004	232,511	0,000	0,000	0,945	0,961	Yes
03_Risk_expo1_G-Envir_Eq -> 02_G-Envir_Eq	0,522 ***	0,522	0,016	33,170	0,000	0,001	0,491	0,553	Yes
04_Risk_expo2_G-Envir_Eq -> 02_G-Envir_Eq	0,114 ***	0,114	0,017	6,696	0,000	0,000	0,081	0,147	Yes
05_Task_efforts1_G-Envir_Eq -> 02_G-Envir_Eq	0,771 ***	0,770	0,010	74,584	0,000	0,000	0,750	0,791	Yes
06_Task_efforts2_G-Envir_eq -> 02_G-Envir_Eq	0,200 ***	0,200	0,015	13,156	0,000	0,000	0,171	0,229	Yes
15_Satisfaction_G-Results_Effects -> 11_Positive_Outcomes	0,676 ***	0,676	0,008	83,308	0,000	0,000	0,660	0,692	Yes
16_Mind_welfare_G-Results_Effects -> 11_Positive_Outcomes	0,458 ***	0,458	0,009	51,011	0,000	0,000	0,440	0,475	Yes
17_Sleep_disorders_G-Results_Effects -> 12_Negative_Outcomes	0,511 ***	0,511	0,009	58,200	0,000	0,000	0,493	0,528	Yes
18_Work_effects1_G-Results_Effects -> 12_Negative_Outcomes	0,652 ***	0,652	0,008	80,767	0,000	0,000	0,636	0,668	Yes

+++p<0,001; ++p<0,01; +p<0,05 (based on t(4999), two-tailed test). t(0,001;4999)=3,292; t(0,01;4999)=2,577; t(0,05; 4999)=1,960

Tabla XLVIII

Se confirma la validez total en todos los componentes Mode B de los cuatro constructos, con p significativo abajo del 0,05.

8.2.3 Análisis del modelo estructural

Una vez confirmada la fiabilidad y validez de las medidas de los constructos, el siguiente paso aborda la valoración de los resultados del modelo estructural. Eso supone examinar la capacidad predictiva del modelo y las relaciones entre los constructos.

El enfoque sistemático para la valoración de los resultados del modelo estructural y de acuerdo con la literatura vigente (Hair et al., 2017), tiene como procedimientos la ejecución de un conjunto de tests que comprende 6 pasos:

- Paso 1 – Valorar la colinealidad en el modelo estructural
- Paso 2 – Valorar la significación y relevancia de las relaciones del modelo estructural (coeficientes *path*)
- Paso 3 – Valorar el nivel (magnitud) de R^2 (coeficiente de determinación; poder predictivo del modelo)
- Paso 4 – Valorar el tamaño de los efectos f^2 (tamaño de efectos)
- Paso 5 – Valorar la relevancia predictiva general Q^2 (relevancia predictiva fuera de la muestra) y relevancia predictiva de modelo a nivel de variable manifiestas (MV) por vía del **PLS-Predict**
- A completarlo, presentamos la Bondad del Ajuste del modelo a través del índice – SRMR

8.2.3.1 Valoración de multicolinealidad potencial (VIF) (modelo estructural)

El test concretado tiene como objetivo verificar si hay presencia de multicolinealidad entre las variables antecedentes de cada uno de los constructos endógenos, puesto que siendo la

estimación de los coeficientes path hecha con base en regresiones OLS, igual que en una regresión múltiple, deberá evitarse cualquier indicio de multicolinealidad. El valor limite en la literatura actual es de $VIF \leq 3$ (Hair, Risher, Sarstedt y Ringle, 2017).

	Inner VIF values	
	11_Positive_ Outcomes	12_Negative_ Outcomes
01_G-Home_Work	1,260	1,315
02_G-Envir_Eq	1,214	1,243
03_RiskAware_07G-Envir_Eq	1,603	1,628
04_Workload_pace_08G-Worload_pace	1,232	1,255
05_DdLines_WPace_10G-Job_Content	1,178	1,218
06_WMeaning_11G-Job_Content	1,677	1,806
07_WorkCond_09G-Control	1,534	1,580
08_Org_relations_12G-Org_Culture	2,651	2,779
09_ChiefRelations_13G-WkRelations	1,957	1,969
10_Present_sit_14_G-Career_dvelop	1,829	1,991
11_Positive_Outcomes		1,929
12_Negative_Outcomes	-	-

Tabla XLIX

8.2.3.2 Valoración de la significación y relevancia de los coeficientes path

Las estimaciones para las relaciones del modelo estructural, i.e., los coeficientes *path*, representan las relaciones hipotetizadas entre constructos.

En lo general se analiza el signo algebraico, la magnitud y la significación estadística.

Al no contener signo para cualquier de las hipótesis, excepto la H11, la cual se confirma su soporte en cuanto al signo, negativo, proseguimos para la magnitud, que baliza los coeficientes path entre -1 y +1, lo que se verificó.

Cuanto a la valoración de la significación, el proceso se compone de un test bootstrap de 5000 muestras, bias-corrected and accelerated BCa, 2 colas (two tailed test), con $p_{value} < 0,05$ y uno otro igual, pero de 1 cola, para testar la hipótesis H11 ya que lleva signo.

Los resultados son los presentados en la página siguiente:

	Two-tailed Bootstrap					Confidence intervals bias-corrected				
	Original Sample (O)	Sample Mean (M)	Standard Deviation (STDEV)	T Statistics (O/STDEV)	P Values	Bias	2.5%	97.5%	Hypothesis confirmation	
01_G-Home_Work -> 11_Positive_Outcomes	-0,122 ⁺⁺⁺	-0,122	0,005	24,100	0,000	0,000	-0,132	-0,112	H1a	Yes
01_G-Home_Work -> 12_Negative_Outcomes	0,211 ⁺⁺⁺	0,211	0,006	37,540	0,000	0,000	0,199	0,222	H1b	Yes
02_G-Envir_Eq -> 11_Positive_Outcomes	-0,023 ⁺⁺⁺	-0,023	0,005	4,331	0,000	0,000	-0,032	-0,012	H2a	Yes
02_G-Envir_Eq -> 12_Negative_Outcomes	0,202 ⁺⁺⁺	0,202	0,005	38,013	0,000	0,000	0,191	0,212	H2b	Yes
03_RiskAware_07G-Envir_Eq -> 11_Positive_Outcomes	0,043 ⁺⁺⁺	0,043	0,006	7,411	0,000	0,000	0,031	0,054	H3a	Yes
03_RiskAware_07G-Envir_Eq -> 12_Negative_Outcomes	-0,019 ⁺⁺	-0,019	0,005	3,395	0,001	0,000	-0,030	-0,008	H3b	Yes
04_Workload_pace_08G-Worload_pace -> 11_Positive_Outcomes	-0,011 ⁺	-0,011	0,005	2,192	0,028	0,000	-0,021	-0,001	H4a	Yes
04_Workload_pace_08G-Worload_pace -> 12_Negative_Outcomes	0,223 ⁺⁺⁺	0,223	0,005	44,953	0,000	0,000	0,213	0,233	H4b	Yes
05_DdLines_WPace_10G-Job_Content -> 11_Positive_Outcomes	-0,027 ⁺⁺⁺	-0,027	0,005	5,664	0,000	0,000	-0,036	-0,018	H5a	Yes
05_DdLines_WPace_10G-Job_Content -> 12_Negative_Outcomes	0,149 ⁺⁺⁺	0,149	0,005	30,667	0,000	0,000	0,140	0,159	H5b	Yes
06_WMeaning_11G-Job_Content -> 11_Positive_Outcomes	0,234 ⁺⁺⁺	0,234	0,006	37,614	0,000	0,000	0,222	0,247	H6a	Yes
06_WMeaning_11G-Job_Content -> 12_Negative_Outcomes	-0,027 ⁺⁺⁺	-0,027	0,006	4,356	0,000	0,000	-0,039	-0,015	H6b	Yes
07_WorkCond_09G-Control -> 11_Positive_Outcomes	0,068 ⁺⁺⁺	0,068	0,005	12,451	0,000	0,000	0,058	0,079	H7a	Yes
07_WorkCond_09G-Control -> 12_Negative_Outcomes	0,103 ⁺⁺⁺	0,103	0,005	19,075	0,000	0,000	0,093	0,114	H7b	Yes
08_Org_relations_12G-Org_Culture -> 11_Positive_Outcomes	0,188 ⁺⁺⁺	0,188	0,008	24,908	0,000	0,000	0,173	0,203	H8a	Yes
08_Org_relations_12G-Org_Culture -> 12_Negative_Outcomes	-0,032 ⁺⁺⁺	-0,032	0,007	4,400	0,000	0,000	-0,047	-0,018	H8b	Yes
09_ChiefRelations_13G-WkRelations -> 11_Positive_Outcomes	0,005 ^{n.s.}	0,005	0,006	0,732	0,464	0,000	-0,008	0,017	H9a	No
09_ChiefRelations_13G-WkRelations -> 12_Negative_Outcomes	0,009 ^{n.s.}	0,009	0,006	1,401	0,161	0,000	-0,004	0,020	H9b	No
10_Present_sit_14_G-Career_dvlop -> 11_Positive_Outcomes	0,258 ⁺⁺⁺	0,258	0,006	41,710	0,000	0,000	0,245	0,269	H10a	Yes
10_Present_sit_14_G-Career_dvlop -> 12_Negative_Outcomes	0,014 ⁺	0,014	0,006	2,264	0,024	0,000	0,002	0,027	H10b	Yes
Age -> 12_Negative_Outcomes	0,032 ⁺⁺⁺	0,032	0,004	7,098	0,000	0,000	0,023	0,041	-	n.a.
Company_Dimension -> 12_Negative_Outcomes	0,013 ⁺	0,013	0,005	2,466	0,014	0,000	0,002	0,023	-	n.a.
Country -> 12_Negative_Outcomes	0,031 ⁺⁺⁺	0,031	0,004	7,287	0,000	0,000	0,022	0,039	-	n.a.
Fixed_Term_Contract -> 12_Negative_Outcomes	-0,005 ^{n.s.}	-0,005	0,004	1,120	0,263	0,000	-0,014	0,004	-	n.a.
Full_PartTime_Work -> 12_Negative_Outcomes	-0,001 ^{n.s.}	-0,001	0,005	0,200	0,841	0,000	-0,010	0,008	-	n.a.
Gender -> 12_Negative_Outcomes	0,090 ⁺⁺⁺	0,090	0,004	20,685	0,000	0,000	0,081	0,098	-	n.a.
Public_sector -> 12_Negative_Outcomes	0,000 ^{n.s.}	0,000	0,004	0,053	0,958	0,000	-0,009	0,009	-	n.a.
Temp_Agency_Contract -> 12_Negative_Outcomes	0,002 ^{n.s.}	0,002	0,005	0,465	0,642	0,000	-0,007	0,012	-	n.a.
Working_centers -> 12_Negative_Outcomes	0,012 ⁺	0,012	0,005	2,453	0,014	0,000	0,003	0,022	-	n.a.

+++p<0,001; ++p<0,01; +p<0,05 (based on t(4999), two-tailed test). t(0,001;4999)=3,292; t(0,01;4999)=2,577; t(0,05; 4999)=1,960

	One-tailed Bootstrap					Confidence intervals bias-corrected				
	Original Sample (O)	Sample Mean (M)	Standard Deviation (STDEV)	T Statistics (O/STDEV)	P Values	Bias	5,0%	95,0%	Hypothesis confirmation	
11_Positive_Outcomes -> 12_Negative_Outcomes	-0,298 ⁺⁺⁺	-0,298	0,007	42,878	0,000	0,000	-0,310	-0,287	H11 (-)	Yes

***p<0,001; **p<0,01; *p<0,05 (based on t(4999), one-tailed test). t(0,001; 4999)=3,092; t(0,01; 4999)=2,327; t(0,05; 4999)=1,645.

Tabla L

En cuanto a la significación de los coeficientes *path*, verificamos que todos fueran validados con *pvalue* <0,05 excepto dos regresiones, las que conectan el constructo **09_ChiefRelations_13G-WkRelations** a las variables de resultados **11_Positive_Outcomes** y **12_Negative_Outcomes**.

La hipótesis H11 en la que postulamos haber efectos negativos significantes de **11_Positive_Outcomes** en **12_Negative_Outcomes**, fue igualmente verificada.

En este apartado también hicimos el análisis de la relevancia de las relaciones significativas. Muchos estudios no acometen este paso tan solo centrándose en la significación de los efectos, pero un coeficiente *path* puede presentarse como significativo a pesar de su efecto muy pequeño ó despreciable, lo que sucede a menudo con tamaños muestrales grandes, como el caso presente. Para eso, hay que considerar los efectos indirectos por vía de mediadores, adicionándolos a los directos, ó sea, deberá tomarse la suma de los efectos directos e indirectos para conocerse el efecto total. A ejemplo (Hair *et al.*, 2017), si un constructo Y_1 tiene un efecto directo de 0,20 en el constructo endógeno Y_3 , pero al tener un efecto de 0,80 en un constructo mediador Y_2 y este de 0,50 en Y_3 , el efecto total de Y_1 es de $0,20 + 0,80 * 0,50 = 0,60$. En este ejemplo, el efecto directo de Y_1 a Y_3 no es destacable, pero su efecto total (combinación de efecto directo y indirecto) es muy pronunciado (0,60), indicando la importancia de Y_1 a la hora de explicar Y_3 .

A continuación, es presentado el cuadro de efectos totales.

Total effects over both results variables

CONSTRUCTS	11_Positive_Outcomes	12_Negative_Outcomes
01_G-Home_Work	-0,122	0,247
02_G-Envir_Eq	-0,023	0,208
03_RiskAware_07G-Envir_Eq	0,043	-0,031
04_Workload_pace_08G-Worload_pace	-0,011	0,226
05_DdLines_WPace_10G-Job_Content	-0,027	0,157
06_WMeaning_11G-Job_Content	0,234	-0,097
07_WorkCond_09G-Control	0,068	0,083
08_Org_relations_12G-Org_Culture	0,188	-0,089
09_ChiefRelations_13G-WkRelations	0,005	0,007
10_Present_sit_14_G-Career_dvlop	0,258	-0,063

Tabla LI

Total Effects over 12_Negative_Outcomes

	Effect	Original Sample Mean (M) (O)	Sample Mean (M)	Standard Deviation (STDEV)	T Statistics (O/STDEV)	P Values
01_G-Home_Work -> 12_Negative_Outcomes	Direct	0,211	0,211	0,006	37,540	0,000
	Indirect	0,037	0,037	0,002	20,916	0,000
	Total	0,247	0,247	0,006	44,090	0,000
02_G-Envir_Eq -> 12_Negative_Outcomes	Direct	0,202	0,202	0,005	38,013	0,000
	Indirect	0,007	0,007	0,002	4,296	0,000
	Total	0,209	0,209	0,006	37,895	0,000
03_RiskAware_07G-Envir_Eq -> 12_Negative_Outcomes	Direct	-0,019	-0,019	0,005	3,395	0,001
	Indirect	-0,013	-0,013	0,002	7,261	0,000
	Total	-0,031	-0,031	0,006	5,451	0,000
04_Workload_pace_08G-Worload_pace -> 12_Negative_Outcomes	Direct	0,223	0,223	0,005	44,953	0,000
	Indirect	0,003	0,003	0,002	2,177	0,030
	Total	0,226	0,226	0,005	43,919	0,000
05_DdLines_WPace_10G-Job_Content -> 12_Negative_Outcomes	Direct	0,149	0,149	0,005	30,667	0,000
	Indirect	0,008	0,008	0,001	5,596	0,000
	Total	0,157	0,157	0,005	30,848	0,000
06_WMeaning_11G-Job_Content -> 12_Negative_Outcomes	Direct	-0,027	-0,027	0,006	4,356	0,000
	Indirect	-0,070	-0,070	0,002	29,072	0,000
	Total	-0,097	-0,097	0,006	15,842	0,000
07_WorkCond_09G-Control -> 12_Negative_Outcomes	Direct	0,103	0,103	0,005	19,075	0,000
	Indirect	-0,020	-0,020	0,002	12,003	0,000
	Total	0,083	0,083	0,006	14,622	0,000
08_Org_relations_12G-Org_Culture -> 12_Negative_Outcomes	Direct	-0,032	-0,032	0,007	4,400	0,000
	Indirect	-0,056	-0,056	0,003	21,384	0,000
	Total	-0,088	-0,088	0,008	11,695	0,000
09_ChiefRelations_13G-WkRelations -> 12_Negative_Outcomes	Direct	0,009	0,009	0,006	1,401	0,161
	Indirect	-0,001	-0,001	0,002	0,732	0,464
	Total	0,007	0,007	0,007	0,941	0,342
10_Present_sit_14_G-Career_dvlop -> 12_Negative_Outcomes	Direct	0,014	0,014	0,006	2,264	0,024
	Indirect	-0,077	-0,077	0,003	29,856	0,000
	Total	-0,063	-0,063	0,006	9,740	0,000

Se identificaron interesantes desarrollos en cuanto a los efectos producidos sobre la variable mediadora y sobre la endógena, a comentárselos más tarde.

A continuación, puede apreciarse el modelo estudiado con indicación de $T_{\text{statistics}}$, **coefficient paths** y significación de los mismos (p_{value}).



Figura 28

8.2.3.3 Valoración del nivel (magnitud) de R2 (coeficiente de determinación; poder predictivo del modelo)

Esta es la medida más comúnmente utilizada para evaluar el modelo estructural, con la cual se mide el nivel de la varianza explicada por la variable dependiente. Corresponde a una medida del poder predictivo del modelo. Como R^2 es la correlación al cuadrado de los valores reales y los de predicción y, por lo tanto, incluye los datos utilizados para estimación, al final representa la medida del poder predictivo en la muestra (Hair *et al.*, 2017 *apud.*, [Rigdon, 2012; Sarstedt, Ringle, Henseler y Hair, 2014]).

Su valor va de 0 a 1, y cuanto mayor sea, será más destacable el nivel de precisión en la predicción. Según autores (Chin, 1998; Hair *et al.*, 2014), la interpretación de R^2 es la siguiente:

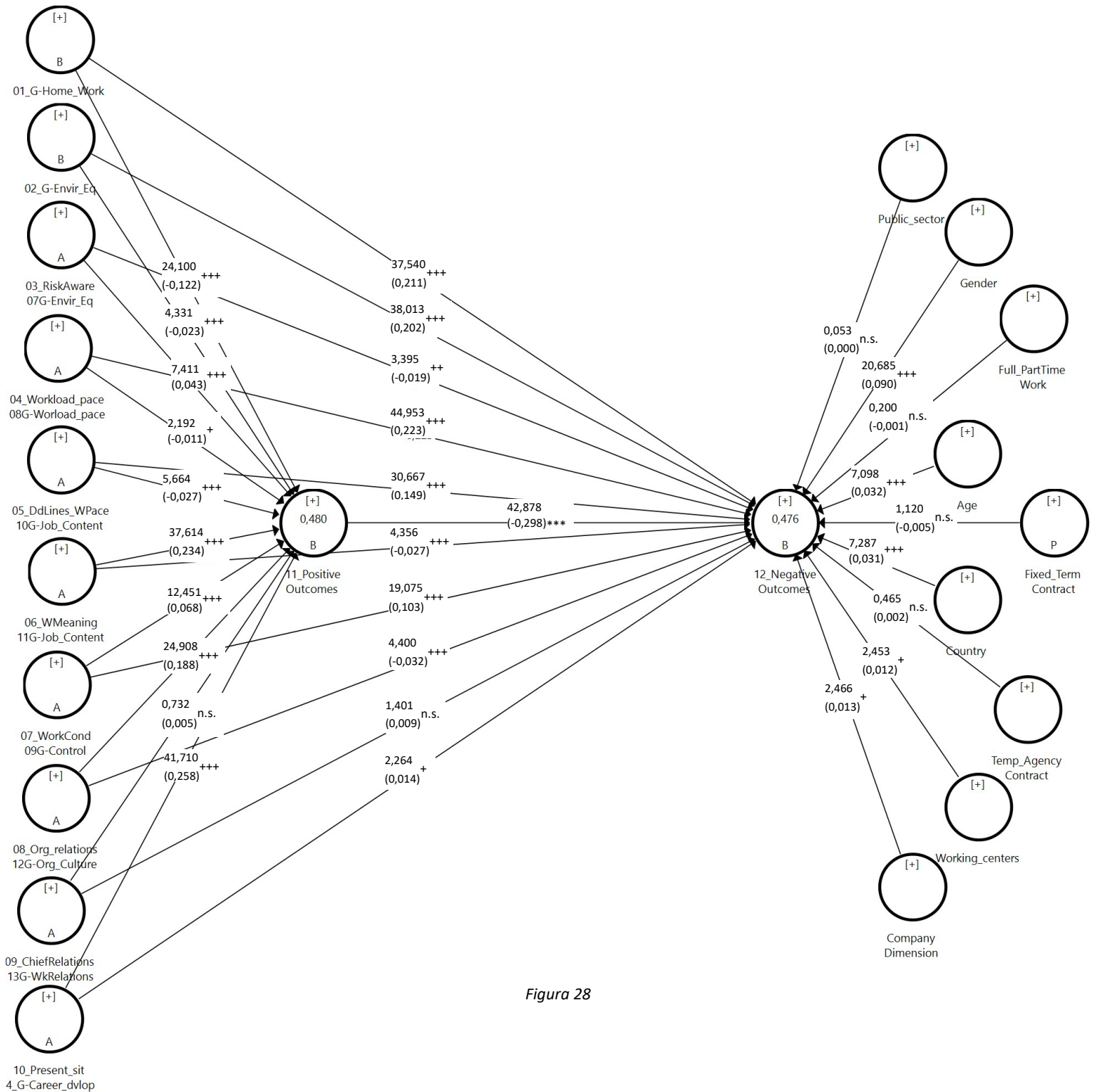
- Débil cuando $0.19 \leq R^2 < 0.33$; moderado cuando $0.33 \leq R^2 < 0.67$; sustancial si $R^2 \geq 0.67$ (Chin, 1998)
- Débil para valores $0.25 \leq R^2$; moderado cuando $0.5 \leq R^2 < 0.75$, sustancial si $R^2 \geq 0.75$ (Hair *et al.*, 2014)

Explained variance; model's predictive power		
	R Square	R Square Adjusted
11_Positive_Outcomes	0,480	0,480
12_Negative_Outcomes	0,476	0,476

Tabla LIII

El coeficiente de determinación ajustado (R^2_{adj}) es la medida que habrá a considerar. Del análisis resulta la calificación de “moderado”, lo que es muy satisfactorio.

En este ámbito, otro análisis requerido es la descomposición de la varianza explicada, a decir, resume el funcionamiento del concepto de R^2 , elucidando sobre el porcentaje de esa varianza del constructo que es causado por una variable latente que la antecede y se relaciona.

Variance decomposition

	R ²	Coefficient path	Correlation (discriminant validity)	Explained Variance	TOTAL
11_Positive_Outcomes	0,480				
01_G-Home_Work		-0,122	-0,357	4,355%	
02_G-Envir_Eq		-0,023	-0,182	0,419%	
03_RiskAware_07G-Envir_Eq		0,043	0,409	1,759%	
04_Workload_pace_08G-Worload_pace		-0,011	-0,087	0,096%	
05_DdLines_WPace_10G-Job_Content		-0,027	-0,168	0,454%	
06_WMeaning_11G-Job_Content		0,234	0,536	12,542%	
07_WorkCond_09G-Control		0,068	0,390	2,652%	
08_Org_relations_12G-Org_Culture		0,188	0,588	11,054%	
09_ChiefRelations_13G-WkRelations		0,005	0,448	0,224%	
10_Present_sit_14_G-Career_dvlop		0,258	0,561	14,474%	48,029%
12_Negative_Outcomes	0,476				
01_G-Home_Work		0,211	0,434	9,157%	
02_G-Envir_Eq		0,202	0,423	8,545%	
03_RiskAware_07G-Envir_Eq		-0,019	-0,195	0,371%	
04_Workload_pace_08G-Worload_pace		0,223	0,407	9,076%	
05_DdLines_WPace_10G-Job_Content		0,149	0,366	5,453%	
06_WMeaning_11G-Job_Content		-0,027	-0,283	0,764%	
07_WorkCond_09G-Control		0,103	-0,048	-0,494%	
08_Org_relations_12G-Org_Culture		-0,032	-0,337	1,078%	
09_ChiefRelations_13G-WkRelations		0,009	-0,223	-0,201%	
10_Present_sit_14_G-Career_dvlop		0,014	-0,270	-0,378%	
11_Positive_Outcomes		-0,298	-0,446	13,291%	
Age		0,032	-0,016	-0,051%	
Company_Dimension		0,013	0,083	0,108%	
Country		0,031	0,068	0,211%	
Fixed_Term_Contract		-0,005	-0,003	0,002%	
Full_PartTime_Work		-0,001	0,048	-0,005%	
Gender		0,090	0,072	0,648%	
Public_sector		0,000	0,022	0,000%	
Temp_Agency_Contract		0,002	-0,006	-0,001%	
Working_centers		0,012	0,067	0,080%	47,654%

Tabla LIV

En conclusión, se puede extraer que, en cuanto a la variable endógena **11_Positive_outcomes**, esta tiene su varianza explicada (48%) por influencia dominante del constructo **10_Present_sit_14_G-Career_dvlop** cuya contribución(14,474%) supera 30% del total, seguido de **06_WMeaning_11G-Job_Content** (12,542%) con más de 26%, y de **08_Org_relations_12G-Org_Culture** (11,054%) con 23% del total, correspondiendo estos tres constructos al 80% de la varianza explicada por la variable endógena asociada a resultados.

Idéntico análisis se extrae de la variable endógena final, donde **11_Positive_Outcomes** (13,291%) contribuye con casi 28%, siguiéndose cuatro constructos influyentes en su contribución (**01_G-Home_Work**; **04_Workload_pace_08G-Workload_pace**; **02_G-Envir_Eq**; y **05_DdLines_WPace_10G-Job_Content**) representando más del 69%, por lo que el conjunto contribuye con casi 73% del total de varianza explicada.

8.2.3.4 Valoración del tamaño de los efectos f^2 (tamaño de efectos)

Con esta medida, que es complementaria a R^2 , se pretende verificar si, al omitir un constructo endógeno en el modelo, ese constructo omitido tiene impacto sustancial sobre los demás. Su determinación resulta de la aplicación de la formulación siguiente:

$$f^2 = \frac{R^2_{\text{incluido}} - R^2_{\text{excluido}}}{1 - R^2_{\text{incluido}}}$$

Según Cohen (1988), las guías para este indicador son las siguientes:

- Efecto pequeño $0.02 \leq f^2 < 0.15$
- Efecto medio $0.15 \leq f^2 < 0.35$
- Efecto grande $f^2 \geq 0.35$

f^2 Exogenous variables impact over each endogenous construct					
	11_Positive_Outcomes	Effect size		12_Negative_Outcomes	Effect size
01_G-Home_Work	0,023	Small		0,064	Small
02_G-Envir_Eq	0,001	Null		0,063	Small
03_RiskAware_07G-Envir_Eq	0,002	Null		0,000	Null
04_Workload_pace_08G-Worload_pace	0,000	Null		0,076	Small
05_DdLines_WPace_10G-Job_Content	0,001	Null		0,035	Small
06_WMmeaning_11G-Job_Content	0,063	Small		0,001	Null
07_WorkCond_09G-Control	0,006	Null		0,013	Null
08_Org_relations_12G-Org_Culture	0,026	Small		0,001	Null
09_ChiefRelations_13G-WkRelations	0,000	Null		0,000	Null
10_Present_sit_14_G-Career_dvelop	0,070	Small		0,000	Null
11_Positive_Outcomes				0,088	Small
12_Negative_Outcomes				-	

Tabla LV

Queda la evidencia de la importancia de la medida del tamaño de los efectos de las variables exógenas, ya que todas las regresiones del cuadro anterior se presentaban con significancia.

8.2.3.5 Valoración de la relevancia predictiva Q^2 (poder predictivo fuera de la muestra – test de Stone-Geisser)

Este análisis al modelo estructural permite extraer un valor que mide el poder predictivo del modelo fuera de la muestra, o también conocido como relevancia predictiva. Según Hair y colegas (2017), cuando un modelo muestra relevancia predictiva, predice con precisión los datos no utilizados en la estimación del modelo.

El valor de Q^2 se obtiene utilizando el procedimiento *blindfolding*, que es una técnica de reutilización de la muestra que omite cada d -ésimo dato de los indicadores del constructo endógeno y estima los parámetros con los datos restantes (Hair *et al.*, 2017, apud. [Chin, 1998; Henseler *et al.*, 2009; Tenenhaus *et al.*, 2005]).

Según Hair y colegas (2019) la valoración de la relevancia predictiva del modelo tiene los siguientes niveles:

- Bajo si $0 < Q^2 \leq 0,25$; medio cuanto $0,25 < Q^2 \leq 0,50$; Elevado si $Q^2 > 0,50$
- Valores nulos (cero) o negativos significan una falta de relevancia predictiva.

El resultado del test Stone-Geisser se presenta a continuación, con asignación de 7 en cuanto a la distancia de omisión D, lo cual significa omitir 14,285% de los datos a cada ronda (siete rondas) del blindfolding, o sea, con esa omisión de datos se indaga si el modelo podrá predecirlos:

Predictive power Q^2	SSO	SSE	$Q^2 (=1-SSE/SSO)$
01_G-Home_Work	60636	60636	
02_G-Envir_Eq	121272	121272	
03_RiskAware_07G-Envir_Eq	90954	90954	
04_Workload_pace_08G-Worload_pace	60636	60636	
05_DdLines_WPace_10G-Job_Content	60636	60636	
06_WMeaning_11G-Job_Content	121272	121272	
07_WorkCond_09G-Control	181908	181908	
08_Org_relations_12G-Org_Culture	242544	242544	
09_ChiefRelations_13G-WkRelations	181908	181908	
10_Present_sit_14_G-Career_dvelop	90954	90954	
11_Positive_Outcomes	60636	39069,11	0,356
12_Negative_Outcomes	60636	39666,67	0,346
Age	30318	30318	
Company_Dimension	30318	30318	
Country	30318	30318	
Fixed_Term_Contract	30318	30318	
Full_PartTime_Work	30318	30318	
Gender	30318	30318	
Public_sector	30318	30318	
Temp_Agency_Contract	30318	30318	
Working_centers	30318	30318	

Tabla LVI

Los resultados obtenidos aportan un claro soporte a la relevancia predictiva del modelo en lo que a las variables endógenas respecta, con aceptación en la categoría media.

Llegados aquí, hay un detalle que importaría subrayar, la literatura actual no es particularmente enfática en recomendar el test de blindfolding para variables formativas de constructos endógenos, sino para constructos reflectivos. Cómo tal, uno deberá coger con precaución científica y prudencia el resultado obtenido.

Por ese motivo, decidimos extender el análisis predictivo a los indicadores manifiestos de las variables endógenas.

8.2.3.6 Análisis de la relevancia predictiva del modelo estructural vía PLS-Predict

Lo primero a comentar es que PLS puede ser utilizado tanto para la investigación **predictiva** como para investigación **explicativa** (Roldán y Cepeda, 2020, *apud.* Shmueli y Koppius, 2011): Un modelo explicativo trata de servir el propósito de testar hipótesis causales que especifican

cómo y por qué cierto fenómeno empírico ocurre; por otro lado, un modelo predictivo hace referencia a su construcción y valoración con el propósito de predecir nuevas/futuras observaciones o escenarios, o sea, tener capacidad para generar predicciones precisas de nuevas observaciones.

Usualmente los investigadores que recurren al PLS subrayan la naturaleza predictiva de su análisis a través de métricas que valoran el poder explicativo (en la muestra) del nomograma, en las cuales se destaca el coeficiente de determinación R^2 y la capacidad predictiva en su general Q^2 . El punto clave en la discusión actual es que estas métricas no añaden conocimiento realista cuanto a la precisión (del modelo) para predecir valores resultados de nuevos casos (no incluidos en la muestra empleada para estimar los parámetros). De hecho, fue desarrollada otra técnica para medir la validez predictiva de los modelos PLS, utilizando *holdout samples*. Shmueli et al., (2016) propone un procedimiento, ya integrado en SmartPLS desde la versión 3.2.6 lo cual permite: (a) comparar modelos para determinar cuál tiene más capacidad de predicción a nivel de indicador y de variables manifiestas (Sharma *et al.*, 2019a,b); y (b) determinar el poder predictivo de un solo modelo (e.g., Danks y Ray, 2018).

De los fundamentos del PLS-Predict constan: dos amuestras, la primera, llamada de *Training Sample*, es una porción del conjunto de datos global utilizada para estimar los parámetros del modelo (e.g., coeficientes path, pesos y cargas de los indicadores); y la *Holdout Sample*, que constituye la parte restante del conjunto de datos que no es utilizada para la estimación del modelo. Para poder predecir el valor de los indicadores de un constructo seleccionado, PLS-Predict utiliza los valores de los casos de la Holdout Sample de los indicadores de los constructos independientes, aplicando las estimaciones de los parámetros del modelo obtenidas a partir de la Training Sample, con el fin de generar predicciones de los indicadores de los constructos dependientes.

La configuración utilizada para el número de secciones (folds) (número de partes en que la muestra es dividida) fue de 9 (k), y el número de repeticiones fue de 10 (r).

Dos estadísticas principales sobresalen: Q^2_{predict} que compara los errores de predicción del modelo PLS frente a simples predicciones basadas en la media de los valores de *Training Sample*, y si es positivo, significa que el modelo PLS tiene mejor rendimiento predictivo; la RMSE (root mean squared error) y MAE (mean absolute error), debiéndose utilizar la primera si los errores de predicción presentan una asimetría debajo de 1, en caso contrario se utiliza el MAE. La diferencia entre los errores (RMSE o MAE) obtenidos por vía del PLS, y por un modelo de regresión lineal (LM) que hace una regresión de todos los indicadores exógenos para predecir cada indicador endógeno, debería ser negativa, o sea, errores más bajos para el modelo PLS (teóricamente sostenido) que los del modelo de regresión (LM).

Por último, el proceso de análisis consta de 3 pasos:

1. Confirmar valores positivos para las variables manifiestas (MV) y, en complemento, para las variables latentes (LV);
2. Evaluar la asimetría (en valor absoluto) de los errores de predicción (para utilizarse RMSE si $|asimetría| < 1$ o MAE si $|asimetría| > 1$);
3. Analizar si la diferencia de errores (RMSE o MAE) es negativa

Los resultados obtenidos después de este test fueron los siguientes:

PLS-Predict analysis

PLS	LM			LM	
	RMSE	MAE	Q ² _predict	RMSE	MAE
15_Satisfaction_G-Results_Effects	0,730	0,562	0,467	0,706	0,543
16_Mind_welfare_G-Results_Effects	0,867	0,660	0,248	0,852	0,648
18_Work_effects1_G-Results_Effects	0,796	0,627	0,367	0,784	0,616
17_Sleep_disorders_G-Results_Effects	0,861	0,679	0,258	0,848	0,668

LV	RMSE	MAE	Q ² _predict
11_Positive_Outcomes	0,722	0,557	0,479
12_Negative_Outcomes	0,756	0,595	0,429

Tabla LVII

Se verifica que el modelo tiene poder predictivo en cuanto a la media de los datos de que se sirve (Training Sample). Pero, a la hora de predecir por vía de las variables manifiestas, el modelo falla el test, ya que sus diferencias entre errores son positivas, por lo cual se concluye que el modelo adolece de un problema de **sobreajuste (overfit)**, o sea, se corresponde muy estrechamente a un conjunto particular de datos y, por lo tanto, fracasa a la hora de ajustarse a datos adicionales o a la hora de predecir de manera fiable observaciones futuras.

Se verifica que el modelo tiene poder predictivo en cuanto a la media de los datos de que se sirve (Training Sample). Pero, a la hora de predecir por vía de las variables manifiestas, el modelo falla el test, una vez que sus diferencias entre errores son positivas, por lo cual se concluye que el modelo adolece de un problema de **sobreajuste (overfit)**, ó sea, se corresponde muy estrechamente a un conjunto particular de datos y, por lo tanto, fracasa a la hora de ajustarse a datos adicionales o a la hora de predecir de manera fiable observaciones futuras.

Por un lado, tenemos medida de capacidad predictiva a través del test blindfolding en cuanto a las variables latentes endógenas, lo que también se confirma en el segundo cuadro de este apartado, que se refiere a las mismas variables latentes. En términos genéricos el modelo aparenta poder predictivo. Pero, cuando se detalla el análisis a nivel de los indicadores manifiestos de esas mismas variables, el modelo falla. Las variables componentes de los dos compuestos finales no consiguen confirmar predicción sino en cuanto a los datos de que se sirven.

En conclusión, este modelo, tal como está dibujado, es sobretodo **explicativo**.

En conversaciones antecedentes, ya habíamos nosotros manifestado alguna prudencia cuanto a la configuración del modelo, que ahora con estos resultados se confirman esos comentarios habidos.

En todo caso, cuanto a este vaticinio final hay que tomárselo con la prudencia científica que el caso requiere, una vez que la teoría desarrollada para PLS-Predict, hasta el momento y en la extensión que conocemos, no hace alusión directa a la especificación de los constructos endógenos.

8.2.3.7 Valoración del ajuste del modelo

PLS ofrece una medida del ajuste del modelo basado en el indicador SRMR (Standardized Root Mean Squared Residuals). Este indicador es la raíz cuadrada de la suma de los cuadrados de las diferencias entre el modelo implícito y la matriz empírica de correlaciones, también conocido como distancia Euclidiana entre dos matrices. Si el valor 0 para SRMR indica un ajuste perfecto, y valores inferiores a 0,05 un ajuste considerable (Henseler *et al.*, 2016: ap. Byrne, 2013), trabajos más recientes de simulación muestran un soporte pleno en modelos especificados en cuanto a valores de SRMR de 0,06 y superiores (Henseler *et al.*, 2014), habiéndose adoptado el límite de hasta **0,08** anteriormente propuesto por Hu y Bentler (1999), como un listón apropiado para separar el ajuste admisible del desajuste del modelo especificado con respecto a la matriz empírica de correlaciones. Así, existe un valor sugerido para que el índice SRMR indique ajuste, **el de ser menor que 0,08**, por más que la literatura no haya establecido en definitivo el umbral que debe ser logrado (Sarstedt, Ringle, Smith, Reams y Hair, 2014).

Nuestros resultados son los siguientes:

	Saturated Model	Estimated Model
SRMR	0,056	0,056

Tabla LVIII

8.3 Determinación de efectos indirectos por mediación

Existen diversos métodos para testar los efectos indirectos que puedan ocurrir en el modelo, por mediación de la variable **11_Positive_Outcomes**, entre los cuales se distinguen Delta methods (Sobel test), Percentile and bias-corrected bootstrap CIs, Distribution of the product, Monte Carlo CI, etc. Hayes y Scharkow (2013) recomiendan para el entorno PLS el test **Percentile bootstrap CI**.

El test presupone 2 pasos:

1. Determinación de la significación de los efectos indirectos (**a_i x b_i**)
2. Determinación del tipo de efecto y su magnitud (**VAF**, Variance accounted for)

El resumen que caracteriza el test es presentado a continuación:

DESCRIPTIVE TABLE FOR MEDIATION STUDY

DIRECT EFFECT 01_G-Home_Work				INDIRECT EFFECT 01_G-Home_Work			
C'1 01_G-Home_Work → 12_Negative_Outcomes				01_G-Home_Work → 11_Positive_Outcomes → 12_Negative_Outcomes			
TOTAL EFFECT (C₀₁) C1 = C'1 + a₀₁ x b							
MEDIATION HYPOTHESIS		Hypothesis 1	n.a.	C'1	Hypothesis 2		Hmed1 a ₀₁ x b
DIRECT EFFECT 02_G-Envir_Eq				INDIRECT EFFECT 02_G-Envir_Eq			
C'2 02_G-Envir_Eq → 12_Negative_Outcomes				02_G-Envir_Eq → 11_Positive_Outcomes → 12_Negative_Outcomes			
TOTAL EFFECT (C₀₂) C2 = C'2 + a₀₂ x b							
MEDIATION HYPOTHESIS		Hypothesis 3	n.a.	C'2	Hypothesis 4		Hmed2 a ₀₂ x b
<hr/> Specification of indirect path a01 = 01_G-Home_Work → 11_Positive_Outcomes b = 11_Positive_Outcomes → 12_Negative_Outcomes							
<hr/> Specification of indirect path a02 = 02_G-Home_Work → 11_Positive_Outcomes b = 11_Positive_Outcomes → 12_Negative_Outcomes							

Figura 29 - figura de la tabla 11

Presentamos estos datos a modo de ejemplo. La tabla completa con la totalidad de los datos se encuentra en la sección final "Sección de Tablas", bajo el título "Tabla 11".

En la tabla de la página siguiente se hace resumen de los resultados obtenidos:

Tabla LIX

POST-HOC ANALYSIS ON INDIRECT EFFECTS												
01_G-Home_Work C'1 Direct effects on 12_Negative_Outcomes				01_G-Home_Work Indirect effects on 12_Negative_Outcomes				Direct + Indirect Effects	VAF	OBS		
Coefficient path		t value		a01	b	a01 x b						
Hypothesis 1	0,211 ***	38,056		Hmed1	-0,122	-0,298	0,037	0,247	14,77%	No Mediation	-	
02_G-Envir_Eq C'2 Direct effects on 12_Negative_Outcomes				02_G-Envir_Eq Indirect effects on 12_Negative_Outcomes								
Coefficient path		t value		a02	b	a02 x b						
Hypothesis 3	0,202 ***	37,844		Hmed2	-0,023	-0,298	0,007	0,208	3,23%	No Mediation	-	
03_RiskAware_07G-Envir_Eq C'3 Direct effects on 12_Negative_Outcomes				03_RiskAware_07G-Envir_Eq Indirect effects on 12_Negative_Outcomes								
Coefficient path		t value		a03	b	a03 x b						
Hypothesis 5	-0,019 ***	3,362		Hmed3	0,043	-0,298	-0,013	-0,031	40,63%	Partial Mediation	Complementary	
04_Workload_pace_08G-Worload_pace C'4 Direct effects on 12_Negative_Outcomes				04_Workload_pace_08G-Worload_pace Indirect effects on 12_Negative_Outcomes								
Coefficient path		t value		a04	b	a04 x b						
Hypothesis 7	0,223 ***	43,736		Hmed4	-0,011	-0,298	0,003	0,226	1,47%	No Mediation	-	
05_DdLines_WPace_10G-Job_Content C'5 Direct effects on 12_Negative_Outcomes				05_DdLines_WPace_10G-Job_Content Indirect effects on 12_Negative_Outcomes								
Coefficient path		t value		a05	b	a05 x b						
Hypothesis 9	0,149 ***	30,668		Hmed5	-0,027	-0,298	0,008	0,157	5,13%	No Mediation	-	
06_WMeaning_11G-Job_Content C'6 Direct effects on 12_Negative_Outcomes				06_WMeaning_11G-Job_Content Indirect effects on 12_Negative_Outcomes								
Coefficient path		t value		a06	b	a06 x b						
Hypothesis 11	-0,027 ***	4,365		Hmed6	0,234	-0,298	-0,070	-0,097	72,14%	Partial Mediation	Complementary	
07_WorkCond_09G-Control C'7 Direct effects on 12_Negative_Outcomes				07_WorkCond_09G-Control Indirect effects on 12_Negative_Outcomes								
Coefficient path		t value		a07	b	a07 x b						
Hypothesis 13	0,103 ***	19,412		Hmed7	0,068	-0,298	-0,020	0,083	24,44%	Partial Mediation	Competitive	
08_Org_relations_12G-Org_Culture C'8 Direct effects on 12_Negative_Outcomes				08_Org_relations_12G-Org_Culture Indirect effects on 12_Negative_Outcomes								
Coefficient path		t value		a08	b	a08 x b						
Hypothesis 15	-0,032 ***	4,461		Hmed8	0,188	-0,298	-0,056	-0,089	63,46%	Partial Mediation	Complementary	
09_ChiefRelations_13G-WkRelations C'9 Direct effects on 12_Negative_Outcomes				09_ChiefRelations_13G-WkRelations Indirect effects on 12_Negative_Outcomes								
Coefficient path		t value		a09	b	a09 x b						
Hypothesis 17	0,009 n.s.	1,427		Hmed9	0,005	-0,298	-0,001	0,007	19,09%	No Mediation	-	
10_Present_sit_14_G-Career_dvlop C'10 Direct effects on 12_Negative_Outcomes				10_Present_sit_14_G-Career_dvlop Indirect effects on 12_Negative_Outcomes								
Coefficient path		t value		a10	b	a10 x b						
Hypothesis 19	0,014 *	2,294		Hmed10	0,258	-0,298	-0,077	-0,063	122,85%	Total Mediation	Competitive	

8.4 Resumen de las hipótesis verificadas y de las no soportadas

Hipotesis	Declaración	
H1a	La variable 01_G-Home_Work está relacionada con 11_Positive_Outcomes	<input checked="" type="checkbox"/>
H1b	La variable 01_G-Home_Work está relacionada con 12_Negative_Outcomes	<input checked="" type="checkbox"/>
H2a	La variable 02_G-Envir_Eq está relacionada con 11_Positive_Outcomes	<input checked="" type="checkbox"/>
H2b	La variable 02_G-Envir_Eq está relacionada con 12_Negative_Outcomes	<input checked="" type="checkbox"/>
H3a	La variable 06_RiskAware_07G-Envir_Eq está relacionada con 11_Positive_Outcomes	<input checked="" type="checkbox"/>
H3b	La variable 06_RiskAware_07G-Envir_Eq está relacionada con 12_Negative_Outcomes	<input checked="" type="checkbox"/>
H4a	La variable 03_Workload_pace_08G-Workload_pace está relacionada con 11_Positive_Outcomes	<input checked="" type="checkbox"/>
H4b	La variable 03_Workload_pace_08G-Workload_pace está relacionada con 12_Negative_Outcomes	<input checked="" type="checkbox"/>
H5a	La variable 04_DdLines_Wpace_10G-Job_Content está relacionada con 11_Positive_Outcomes	<input checked="" type="checkbox"/>
H5b	La variable 04_DdLines_Wpace_10G-Job_Content está relacionada con 12_Negative_Outcomes	<input checked="" type="checkbox"/>
H6a	La variable 05_Wmeaning_11G-Job_Content está relacionada con 11_Positive_Outcomes	<input checked="" type="checkbox"/>
H6b	La variable 05_Wmeaning_11G-Job_Content está relacionada con 12_Negative_Outcomes	<input checked="" type="checkbox"/>
H7a	La variable 07_WorkCond_09G-Control está relacionada con 11_Positive_Outcomes	<input checked="" type="checkbox"/>
H7b	La variable 07_WorkCond_09G-Control está relacionada con 12_Negative_Outcomes	<input checked="" type="checkbox"/>
H8a	La variable 08_Org_relations_12G-Org_Culture está relacionada con 11_Positive_Outcomes	<input checked="" type="checkbox"/>
H8b	La variable 08_Org_relations_12G-Org_Culture está relacionada con 12_Negative_Outcomes	<input checked="" type="checkbox"/>
H9a	La variable 09_ChiefRelations_13G-WkRelations está relacionada con 11_Positive_Outcomes	<input type="checkbox"/>
H9b	La variable 09_ChiefRelations_13G-WkRelations está relacionada con 12_Negative_Outcomes	<input type="checkbox"/>
H10a	La variable 10_Present_sit_14G-Career_Dvlop está relacionada con 11_Positive_Outcomes	<input checked="" type="checkbox"/>
H10b	La variable 10_Present_sit_14G-Career_Dvlop está relacionada con 12_Negative_Outcomes	<input checked="" type="checkbox"/>
H11	La variable 11_Positive_Outcomes está relacionada negativamente con 12_Negative_Outcomes	<input checked="" type="checkbox"/>
Hmed1	La variable 01_G-Home_Work produce efectos indirectos en 12_Negative_Outcomes, a través de 11_Positive_Outcomes	<input type="checkbox"/>
Hmed2	La variable 02_G-Envir_Eq produce efectos indirectos en 12_Negative_Outcomes, a través de 11_Positive_Outcomes	<input type="checkbox"/>
Hmed3	La variable 03_RiskAware_07G-Envir_Eq produce efectos indirectos en 12_Negative_Outcomes, a través de 11_Positive_Outcomes	<input checked="" type="checkbox"/>
Hmed4	La variable 04_Workload_pace_08G-Workload_pace produce efectos indirectos en 12_Negative_Outcomes, a través de 11_Positive_Outcomes	<input type="checkbox"/>
Hmed5	La variable 05_DdLines_Wpace_10G-Job_Content produce efectos indirectos en 12_Negative_Outcomes, a través de 11_Positive_Outcomes	<input type="checkbox"/>
Hmed6	La variable 06_Wmeaning_11G-Job_Content produce efectos indirectos en 12_Negative_Outcomes, a través de 11_Positive_Outcomes	<input checked="" type="checkbox"/>
Hmed7	La variable 07_WorkCond_09G-Control produce efectos indirectos en 12_Negative_Outcomes, a través de 11_Positive_Outcomes	<input checked="" type="checkbox"/>
Hmed8	La variable 08_Org_relations_12G-Org_Culture produce efectos indirectos en 12_Negative_Outcomes, a través de 11_Positive_Outcomes	<input checked="" type="checkbox"/>
Hmed9	La variable 09_ChiefRelations_13G-WkRelations produce efectos indirectos en 12_Negative_Outcomes, a través de 11_Positive_Outcomes	<input type="checkbox"/>
Hmed10	La variable 10_Present_sit_14G-Career_Dvlop produce efectos indirectos en 12_Negative_Outcomes, a través de 11_Positive_Outcomes	<input checked="" type="checkbox"/>

Tabla LX

8.4.1 Interpretación del modelo V01

Este modelo describe los efectos causales de las condiciones de trabajo que son medidas a través de la encuesta EWCS 2015.

En primer lugar, identificamos dos tipos de estados resultantes: negativos y positivos, los cuales son resumidos por un par de variables (compuestos latentes de primer orden) cada uno, los resultados

positivos por 15_Satisfaction y 16_Mind_welfare, y los negativos por 17_Sleep_disorders y 18_Work_effects.

Para que estas variables resultado puedan tener sentido, son explicadas por un conjunto de variables exógenas que determinan su existencia, teniendo las causalidades de las variables exógenas un impacto significativo a nivel $p > 0,005$, tal como se verifica en la Figura 28.

En concreto, son 10 las variables exógenas que repercuten sobre las variables de resultados positivos y de resultados negativos:

1. La variable latente exógena 01_G-Home_Work hace referencia al cambio en número de horas, la influencia en el puesto de trabajo y a las tareas del mismo, así como a la adaptación de éste a compromisos fuera de él, suponiendo esto un impacto negativo (-0,122) sobre resultados positivos, y un impacto positivo (0,211) sobre resultados negativos o sea, hay más influencia de efectos negativos que de positivos. El balance de este compuesto es más tendente a producir efectos negativos, que se añaden a otros de la misma naturaleza.
2. En cuanto a 02_G-Envir_Eq, es explicada por exposiciones negativas del trabajador en su puesto de trabajo, ya sean ruidos, vibraciones, situaciones molestas o aparatos electrónicos, entre otros, influyendo dicha variable mucho más sobre resultados negativos (0,202), que sobre resultados positivos (-0,023). Tal cómo el compuesto anterior, este tiene igualmente una tendencia fuertemente negativa en su naturaleza o sea, añade efectos a la variable exógena final.
3. La variable 03_RiskAware_07G-Envir_Eq explica la información que el trabajador obtiene sobre temas relacionados con salud y seguridad en el trabajo, así como la ayuda y el apoyo recibido por sus jefes y compañeros, suponiendo esto un impacto positivo sobre resultados positivos (0,043), y además negativo sobre resultados negativos (-0,019) o sea, los disminuye.
4. 04_Workload_pace_08G-Workload_pace se refiere a la necesidad de emplear tiempo libre para el trabajo, así como las interrupciones imprevistas en el mismo, teniendo dichas cuestiones una relevancia mucho mayor a la hora de explicar los efectos negativos (0,223), que los efectos positivos (-0,011) los cuales disminuyen. Claramente es una variable que añade efectos negativos al resultado negativo final.
5. En cuanto a 05_DdLines_WPace_10G-Job_Content: los ritmos de trabajo excesivos y los plazos ajustados; explican positivamente los resultados negativos (0,149), y negativamente los resultados positivos (-0,027) o sea, el impacto dominante es claramente negativo, por lo que influye negativamente a la hora de producir resultados positivos.
6. 06_WMeaning_11G-Job_content se refiere a sentimientos y situaciones positivas en el lugar de trabajo, explicando los datos obtenidos los resultados positivos (0,234) más que los resultados negativos (-0,027). Este compuesto tiene naturaleza positiva absoluta.
7. La variable 07_WorkCond_09G-Control hace referencia la participación e influencia del empleado en decisiones que repercuten en su trabajo, lo cual es más relevante para explicar efectos negativos (0,103), que efectos positivos (0,068).

8. 08_Org_relations_12G-Org_Culture, es decir, la cooperación de empleados y actuación positiva de la dirección de la organización, explican positivamente y sin dudas los resultados positivos (0,188), y además presentan una relación causal negativa con los resultados negativos (-0,032).
9. Las actuaciones positivas de los jefes directos de los trabajadores, son contenidas en la variable 09_ChiefRelations_13WorkRelations, la cual no tiene significancia en cuanto al impacto ni en los resultados positivos (0,005), ni en los resultados negativos (0,009).
10. En cuanto a 10_Present-sit_14_g-Career_develop, reconocimiento económico y personal por el trabajo realizado y posibilidades de ascenso profesional, esta variable tiene mucha más relevancia a la hora de explicar los resultados positivos (0,258), que los resultados negativos (0,014).

Además de ello, existe una relación causal fuertemente negativa entre los dos resultados obtenidos, de manera que el compuesto que simboliza los resultados positivos (11_Positive_Outcomes), los cuales hacen referencia a la satisfacción con las condiciones de trabajo y los sentimientos positivos experimentados por el trabajador, producen fuerte efecto negativo (-0,298) sobre el compuesto final endógeno de los resultados negativos (12_Negative_Outcomes).

8.5 Tabla Resumen

La tabla resumen agrega información en cuanto al valor y significancia de relaciones entre constructos que puedan explicar la variable endógena final. Esta tabla ayuda a la hora de tomar decisiones en cuanto al mantenimiento o supresión de regresiones del modelo estructural, ya que la existencia de un constructo que no se encuadra con los demás en explicar la varianza de constructos endógenos, no deberá mantenerse.

La tabla resumen se compone de 3 cuadros: (a) los coeficientes path (β) que miden las regresiones, analizados en cuanto a su valor y significancia estadística; (b) el tamaño de los efectos producidos por regresiones directas hacia constructos endógenos, y sus significancias estadísticas; (3) por último, la medida de efectos indirectos en la variable endógena final, por vía de mediación, midiéndose la magnitud del efecto y cualificándolo en cuanto al tipo de efecto producido.

SUMMARY TABLE									
VARIABLES	COEFFICIENT PATH β								
	11_Positive_Outcomes				12_Negative_Outcomes				
	Path (β)	Tstatistics	p value	Validity	Path (β)	Tstatistics	p value	Validity	
01_G-Home_Work	-0,122 ⁺⁺⁺	24,100	0,000	Yes	0,211 ⁺⁺⁺	37,540	0,000	Yes	
02_G-Envir_Eq	-0,023 ⁺⁺⁺	4,331	0,000	Yes	0,202 ⁺⁺⁺	38,013	0,000	Yes	
03_RiskAware_07G-Envir_Eq	0,043 ⁺⁺⁺	7,411	0,000	Yes	-0,019 ⁺⁺	3,395	0,001	Yes	
04_Workload_pace_08G-Worload_pace	-0,011 ⁺	2,192	0,028	Yes	0,223 ⁺⁺⁺	44,953	0,000	Yes	
05_DdLines_WPace_10G-Job_Content	-0,027 ⁺⁺⁺	5,664	0,000	Yes	0,149 ⁺⁺⁺	30,667	0,000	Yes	
06_WMeaning_11G-Job_Content	0,234 ⁺⁺⁺	37,614	0,000	Yes	-0,027 ⁺⁺⁺	4,356	0,000	Yes	
07_WorkCond_09G-Control	0,068 ⁺⁺⁺	12,451	0,000	Yes	0,103 ⁺⁺⁺	19,075	0,000	Yes	
08_Org_relations_12G-Org_Culture	0,188 ⁺⁺⁺	24,908	0,000	Yes	-0,032 ⁺⁺⁺	4,400	0,000	Yes	
09_ChiefRelations_13G-WkRelations	0,005 ^{n.s.}	0,732	0,464	No	0,009 ^{n.s.}	1,401	0,161	No	
10_Present_sit_14_G-Career_dvlop	0,258 ⁺⁺⁺	41,710	0,000	Yes	0,014 ⁺	2,264	0,024	Yes	
11_Positive_Outcomes	-	-	-	-	-0,298 ⁺⁺⁺	42,878	0,000	Yes	
Age	-	-	-	-	0,032 ⁺⁺⁺	7,098	0,000	Yes	
Company_Dimension	-	-	-	-	0,013 ⁺	2,466	0,014	Yes	
Country	-	-	-	-	0,031 ⁺⁺⁺	7,287	0,000	Yes	
Fixed_Term_Contract	-	-	-	-	-0,005 ^{n.s.}	1,12	0,263	No	
Full_PartTime_Work	-	-	-	-	-0,001 ^{n.s.}	0,2	0,841	No	
Gender	-	-	-	-	0,090 ⁺⁺⁺	20,685	0,000	Yes	
Public_sector	-	-	-	-	0,000 ^{n.s.}	0,053	0,958	No	
Temp_Agency_Contract	-	-	-	-	0,002 ^{n.s.}	0,465	0,642	No	
Working_centers	-	-	-	-	0,012 ⁺	2,453	0,014	Yes	

+++p<0,001; ++p<0,01; +p<0,05 (based on t(4999), two-tailed test). t(0,001;4999)=3,292; t(0,01;4999)=2,577; t(0,05; 4999)=1,960

***p<0,001; **p<0,01; *p<0,05 (based on t(4999), one-tailed test). t(0,001; 4999)=3,092; t(0,01; 4999)=2,327; t(0,05; 4999)=1,645

Tabla LXI

SUMMARY TABLE		EFFECTS SIZE f^2					
VARIABLES	11_Positive_Outcomes			12_Negative_Outcomes			
	Impact	Effect Size	Validity	Impact	Effect Size	Validity	
01_G-Home_Work	0,023	Small	Yes	0,064	Small	Yes	
02_G-Envir_Eq	0,001	Null	No	0,063	Small	Yes	
03_RiskAware_07G-Envir_Eq	0,002	Null	No	0,000	Null	No	
04_Workload_pace_08G-Worload_pace	0,000	Null	No	0,076	Small	Yes	
05_DdLines_WPace_10G-Job_Content	0,001	Null	No	0,035	Small	Yes	
06_WMeaning_11G-Job_Content	0,063	Small	Yes	0,001	Null	No	
07_WorkCond_09G-Control	0,006	Null	No	0,013	Null	No	
08_Org_relations_12G-Org_Culture	0,026	Small	Yes	0,001	Null	No	
09_ChiefRelations_13G-WkRelations	0,000	Null	No	0,000	Null	No	
10_Present_sit_14_G-Career_dvlop	0,070	Small	Yes	0,000	Null	No	
11_Positive_Outcomes				0,088	Small	Yes	
Age	-	-		0,002	Null	No	
Company_Dimension	-	-		0,000	Null	No	
Country	-	-		0,002	Null	No	
Fixed_Term_Contract	-	-		0,000	Null	No	
Full_PartTime_Work	-	-		0,000	Null	No	
Gender	-	-		0,014	Null	No	
Public_sector	-	-		0,000	Null	No	
Temp_Agency_Contract	-	-		0,000	Null	No	
Working_centers	-	-		0,000	Null	No	

Tabla LXII

SUMMARY TABLE		MEDIATION EFFECTS VAF								
VARIABLES	$a_{xx} \times b$	p value	T statistics	Bootstrap 95% two-tailed				VAF (magnitude)	Qualification	
				CI-Percentil		BC				
				2.5%	97.5%	2.5%	97.5%			
01_G-Home_Work	0,037 ⁺⁺⁺	0,000	20,688	0,033	0,040	0,033	0,040	14,77%	No Mediation	-
02_G-Envir_Eq	0,007 ⁺⁺⁺	0,000	4,349	0,004	0,010	0,004	0,010	3,23%	No Mediation	-
03_RiskAware_07G-Envir_Eq	-0,013 ⁺⁺⁺	0,000	7,263	-0,016	-0,009	-0,016	-0,009	40,63%	Partial Mediation	Complementary
04_Workload_pace_08G-Worload_pace	0,003 ⁺	0,026	2,233	0,000	0,006	0,000	0,006	1,47%	No Mediation	-
05_DdLines_WPace_10G-Job_Content	0,008 ⁺⁺⁺	0,000	5,696	0,005	0,011	0,005	0,011	5,13%	No Mediation	-
06_WMeaning_11G-Job_Content	-0,070 ⁺⁺⁺	0,000	28,725	-0,075	-0,065	-0,075	-0,065	72,14%	Partial Mediation	Complementary
07_WorkCond_09G-Control	-0,020 ⁺⁺⁺	0,000	11,917	-0,024	-0,017	-0,024	-0,017	24,44%	Partial Mediation	Competitive
08_Org_relations_12G-Org_Culture	-0,056 ⁺⁺⁺	0,000	20,960	-0,062	-0,051	-0,062	-0,051	63,46%	Partial Mediation	Complementary
09_ChiefRelations_13G-WkRelations	-0,001 ^{n.s.}	0,463	0,734	-0,005	0,002	-0,005	0,002	19,09%	No Mediation	-
10_Present_sit_14_G-Career_dvlop	-0,077 ⁺⁺⁺	0,000	29,860	-0,082	-0,072	-0,082	-0,072	122,85%	Total Mediation	Competitive
11_Positive_Outcomes										

Tabla LXIII

De los análisis de los 3 cuadros puede concluirse que el constructo **09_ChiefRelations_13G-WkRelations** es **candidato a la supresión**, debido a que no tiene significancia en sus caminos, no produce efectos directos en ninguna de las dos variables endógenas, y en consecuencia, tampoco iría a tener efectos indirectos, como se constata.

Del test de bootstrap se podrá analizar las correlaciones entre constructos, en cuanto a las regresiones a otros constructos y sus significancias. Del hecho descubrimos que este constructo tiene muy fuerte correlación con otro en términos causales, estamos hablando de **08_Org_relations_12G-Org_Culture**. Al considerarse esta relación causal hacia este último constructo, ya no lo suprimíamos. Según el esquema teórico que se nos han fornecido, los dos constructos pertenecen a agrupaciones distintas, pero esta regresión tiene absoluta lógica. Si el sentido de la regresión es de 09 hacia 08 o al revés, es una cuestión simple de la teoría que el modelo puede aportar. Para proceder a un análisis adecuado a esta versión, habría que montar el modelo de medida inicial con regresiones adicionales entre los constructos que a su tiempo se consideraran exógenos, y proceder de nuevo a todo el recorrido de pasos y tests, lo que trasciende el ámbito de lo que fue solicitado.

En conclusión, tenemos tres modelos. Un primero, ya estudiado; del anterior surge una versión truncada de las supresiones que hemos hecho mención; y ahora este, con el cual habría que descubrirse otras relaciones causales para que su ajuste quede equivalente entre el modelo saturado y el modelo especificado. Del último apenas sugerimos que debería ser explotado y rehacer todos los tests, para encontrarse la configuración adecuada que permita sobresalir su naturaleza predictiva.

8.6 Versión final del modelo estructural V01

En esta versión, se quitó el constructo **09_ChiefRelations_13G-WkRelations**, así como las regresiones cuyo efecto es nulo y que no producen efectos vía de mediación:

- 02_G-Envir_Eq → 11_Positive_Outcomes (f^2 nulo; ninguna mediación)
- 04_Workload_pace_08G-Workload_pace → 11_Positive_Outcomes (f^2 nulo; ninguna mediación)
- 05_DdLines_WPace_10G-Job_Content → 11_Positive_Outcomes (f^2 nulo; ninguna mediación)

Con estas acciones, la configuración final de modelo es presentada a continuación.

Todavía hay un detalle a destacar. Una vez que se concluyó de la naturaleza eminentemente explicativa del modelo, consecuencia del análisis a la relevancia predictiva del modelo por PLS-Predict, con sobreajuste a los datos utilizados, uno debería utilizar con prudencia científica y mantener las relaciones causales y el constructo ahora suprimido, por desconocerse que resultados podrían ocurrir en alguna segmentación por análisis multi-grupo, por lo cual podrían proyectarse cambios con significancia de efectos.

Por lo tanto, nuestra recomendación es la de mantener el modelo tal y como está, sin supresiones, pero al ir esto en contra de la opinión transmitida por nuestro coordinador, ofrecemos el modelo ya desproveído de relaciones causales antes señaladas y del constructo citado. Al modelo adelante representado se llamó:

EWCS-general_structural_model-evo3supression_based-V01A

Figura 30

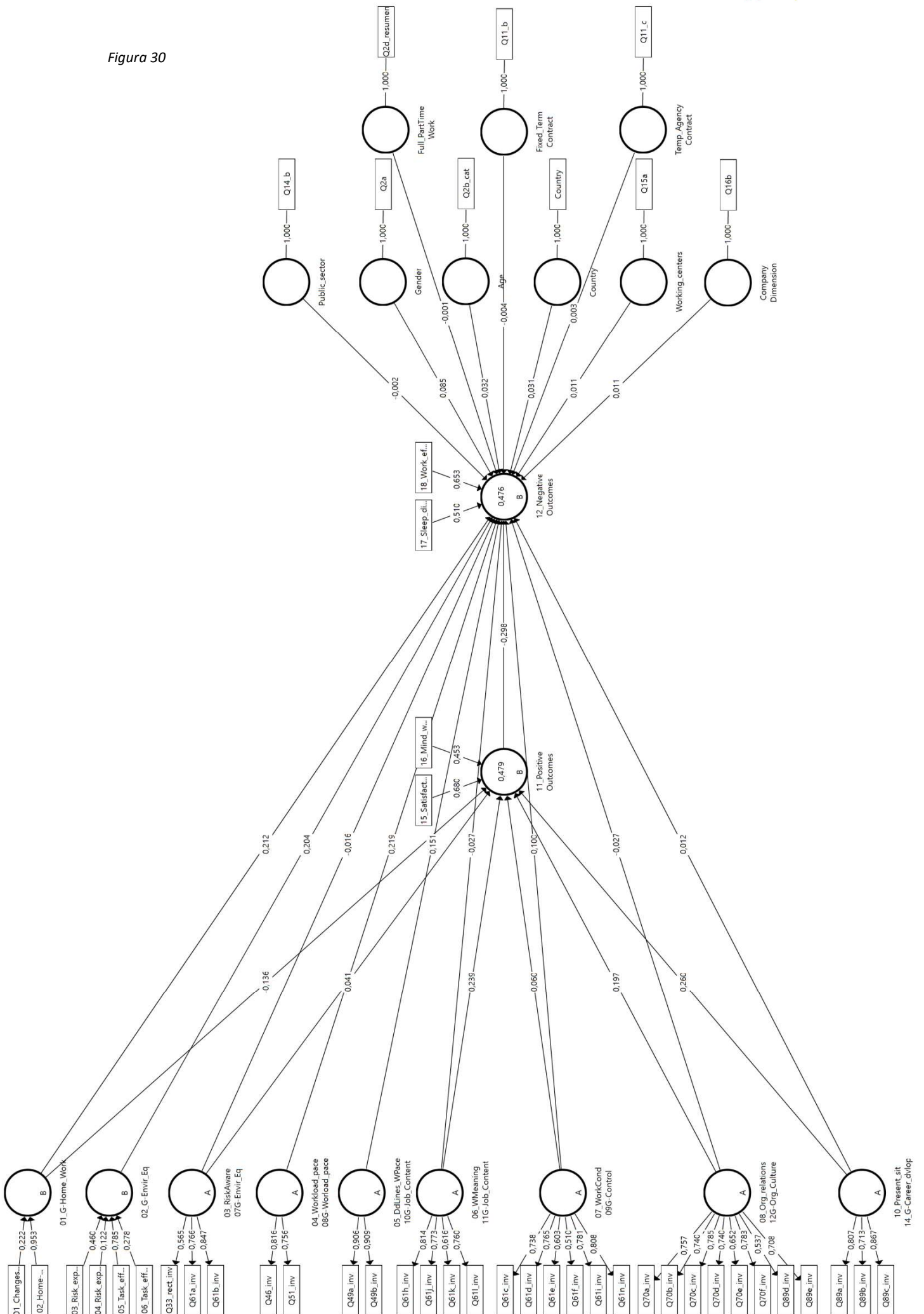

8.7 Ecuaciones estructurales que representan un modelo

Al elaborar la ecuación que pueda representar un modelo, habrá que tener en cuenta efectos directos en la variable endógena, sus indicadores, y efectos indirectos por mediación. En cuanto a los constructos exógenos, hay que considerar su especificación, modo reflectivo o formativo.

La ecuación que presenta un constructo formativo es la siguiente:

$$\xi = \sum_{i=1}^n (w_i \cdot x_i) + \delta$$

Donde, i representa el número de variables medibles, w el peso de la regresión, y δ un término de error de la variable latente ξ a despreciar. Así, la ecuación final tendrá el formato presentado a continuación:

$$\xi = \sum_{i=1}^n (w_i \cdot x_i)$$

En cuanto a los constructos reflectivos, cada variable medible X va a corresponder a una solución lineal, por lo que al existir n variables en el constructo, habrá n soluciones lineales para ese constructo, cada una aportada por la variable medible respectiva:

$$x_i = \lambda_i \cdot \xi + \varepsilon_i$$

Despreciando los términos de error ε a efectos de simplificación, y midiéndose los valores de x , el resultado que podrá obtenerse para el constructo será la media de las mediciones a dividir por la media de las cargas:

$$\xi = \frac{\bar{x}_i}{\bar{\lambda}_i}$$

En cuanto a los constructos exógenos, los hay en Mode B (o sea, formativos) de segunda orden, y en Mode A de primera orden.

Para los compuestos Mode B de segunda orden, estos provienen del modelo de medida, el cual está totalmente especificado en Mode A, por lo que para determinar el valor de cada uno de los componentes del compuesto habrá de proceder a los cálculos a partir del modelo de medida.

Aparte de los efectos causales directos, hay que contar con efectos mediados, los cuales podrán ser adictivos o sustractivos, en conformidad con la naturaleza complementaria o competitiva del efecto moderador. El tercer cuadro de la tabla resumen presenta los coeficientes path para cada camino completo, y sólo habrá que considerar los caminos con $VAF \geq 20\%$.

De todo esto resultará el encuadramiento necesario para producir un indicador sintético.

8.8 Desarrollo del indicador sintético para el modelo V01A

Para el modelo V01A, lo que hay que considerar debidamente son los siguientes datos resumidos en la tabla presentada a continuación.

CONSTRUCTS	Composite specification			Components			Measurement Variables					Scale		
	Simplified Mention	Mode A	Mode B	Level	Simplified Mention	Weights	Simplified Mention	Loads	Scale		Direct	Invert	Factor	
									Min	Max				
01_G-Home_Work	01HW	Y	2	01_Changes_12M_G-Home_Work	01CHHW	0,222	Q18a_inv_LD	Q18ai	0,759	1	5	yes	5+1 - reading value	
							Q18c_inv_LD	Q18ci	0,610	1	5	yes	5+1 - reading value	
02_G-Envir_Eq	02EE	Y	2	02_Home-work1_G-Home_work	02HWHW	0,953	Q18d_inv_LD	Q18di	0,869	1	5	yes	5+1 - reading value	
							Q44_rect	Q44	0,905	1	4	yes		
							Q47_rect	Q47	0,664	1	4	yes		
				03_Risk_expo1_G-Envir_Eq	03RKEE	0,460	Q29a_inv_ReplaceMD_1	Q29ai	0,723	1	7	yes	7+1 - reading value	
							Q29b_inv_ReplaceMD_1	Q29bi	0,779	1	7	yes	7+1 - reading value	
							Q29c_inv_ReplaceMD_1	Q29ci	0,777	1	7	yes	7+1 - reading value	
							Q29d_inv_ReplaceMD_1	Q29di	0,715	1	7	yes	7+1 - reading value	
							Q29e_inv_ReplaceMD_1	Q29ei	0,724	1	7	yes	7+1 - reading value	
				04_Risk_expo2_G-Envir_Eq	04RKEE	0,122	Q29f_inv_LD	Q29fi	0,797	1	7	yes	7+1 - reading value	
							Q29g_inv_LD	Q29gi	0,853	1	7	yes	7+1 - reading value	
			Q29i_inv	Q29ii	0,757	1	7	yes	7+1 - reading value					
			05_Task_efforts1_G-Envir_Eq	05TEEE	0,785	Q30f_inv_ReplaceMD_1	Q30fi	0,554	1	7	yes	7+1 - reading value		
						Q30g_inv_ReplaceMD_1	Q30gi	0,784	1	7	yes	7+1 - reading value		
						Q30h_inv_ReplaceMD_1	Q30hi	0,898	1	7	yes	7+1 - reading value		
			06_Task_efforts2_G-Envir_Eq	06TEEE	0,278	Q30d_inv_LD	Q30di	0,793	1	7	yes	7+1 - reading value		
						Q30i_inv_ReplaceMD_1	Q30ii	0,954	1	7	yes	7+1 - reading value		

Presentamos estos datos a modo de ejemplo. La tabla completa con la totalidad de los datos se encuentra en la sección final "Sección de Tablas", bajo el título "Tabla 12".

Figura 31 - figura de la tabla 12

Un detalle importante en esta tabla es la información contenida en las tres columnas de SCALE (a la derecha de la tabla). Por efectos de conveniencia a la hora de utilizar los datos y teniendo en cuenta el propósito del estudio - medir las consecuencias negativas de las condiciones de trabajo para el trabajador -, utilizamos las escalas invertidas en la mayoría de las cuestiones. En términos futuros, cuando el usuario del cuestionario va a aplicarlo y obtiene, para una determinada cuestión con una escala continua del 1 al 7 que fue tratada como invertida, un resultado de **2**, ese valor en esta cuestión específica tiene que ser convertido. Así que su conversión será lo que resulta del valor máximo de la escala de lectura (**7**), **añadida la unidad y deducido el valor de lectura:** $(7_{\max.\text{scale}} + 1_{\text{Constant}}) - 2_{\text{reading.value}} = 6$. Será el valor **6** lo que hay de introducir en los cálculos para sacar la media y aplicárselo en la formulación del indicador sintético.

A efectos de simplificación, de aquí en adelante utilizamos la nomenclatura de mención simplificada ("simplified mention"; ver columnas en la tabla) a la hora de identificar la variable, donde la letra "i" al final indica el uso de escala invertida.

Las ecuaciones finales que representan el modelo estructural V01A son las siguientes:

Ecuaciones de los compuestos endógenos

$$\begin{aligned}
 [1] \quad \xi_{12NO} &= (0,510 \cdot \mathcal{C}_{17SDRE} + 0,653 \cdot \mathcal{C}_{18WERE}) \\
 &= 0,510 \cdot (\overline{Q61mi} \cdot 0,595 + \overline{Q79ai} \cdot 0,778 + \overline{Q79bi} \cdot 0,779 + \overline{Q79ci} \cdot 0,827) + \\
 &+ 0,653 \cdot (\overline{Q45ai} \cdot 0,656 + \overline{Q45bi} \cdot 0,714 + \overline{Q45ci} \cdot 0,812 + \overline{Q45di} \cdot 0,719 + \overline{Q45ei} \cdot 0,679)
 \end{aligned}$$

$$\begin{aligned}
 [2] \quad \xi_{11PO} &= (0,680 \cdot \mathcal{C}_{15STRE} + 0,453 \cdot \mathcal{C}_{16MWRE}) \\
 &= 0,680 \cdot (\overline{Q88i} \cdot 0,745 + \overline{Q90ai} \cdot 0,798 + \overline{Q90bi} \cdot 0,814 + \overline{Q90ci} \cdot 0,614) + \\
 &+ 0,453 \cdot (\overline{Q87ai} \cdot 0,838 + \overline{Q87bi} \cdot 0,844 + \overline{Q87ci} \cdot 0,853 + \overline{Q87di} \cdot 0,835 + \overline{Q87ei} \cdot 0,741)
 \end{aligned}$$

Ecuaciones de los compuestos exógenos Mode B

$$\begin{aligned}
 [3] \quad \psi_{01WH} &= (0,222 \cdot \mathcal{Y}_{01CHHW} + 0,953 \cdot \mathcal{Y}_{02HWHW}) \\
 &= 0,222 \cdot (\overline{Q18ai} \cdot 0,759 + \overline{Q18ci} \cdot 0,610 + \overline{Q18di} \cdot 0,869) + 0,953 \cdot (\overline{Q44} \cdot 0,905 + \overline{Q47} \cdot 0,664)
 \end{aligned}$$

$$\begin{aligned}
 [4] \quad \psi_{02EE} &= (0,460 \cdot \mathcal{Y}_{03RKEE} + 0,122 \cdot \mathcal{Y}_{04RKEE} + 0,785 \cdot \mathcal{Y}_{05TEEE} + 0,278 \cdot \mathcal{Y}_{06TEEE}) = \\
 &= 0,460 \cdot (\overline{Q29ai} \cdot 0,723 + \overline{Q29bi} \cdot 0,779 + \overline{Q29ci} \cdot 0,777 + \overline{Q29di} \cdot 0,715 + \overline{Q29ei} \cdot 0,724) + \\
 &+ 0,122 \cdot (\overline{Q29fi} \cdot 0,797 + \overline{Q29gi} \cdot 0,853 + \overline{Q29ii} \cdot 0,757) + 0,785 \cdot (\overline{Q30fi} \cdot 0,554 + \overline{Q30gi} \cdot 0,784 + \overline{Q30hi} \cdot 0,898) + \\
 &+ 0,278 \cdot (\overline{Q30di} \cdot 0,793 + \overline{Q30ii} \cdot 0,954)
 \end{aligned}$$

Ecuaciones de los compuestos exógenos Mode A

$$[5] \quad \Phi_{03RiskEE} = \mathcal{K}_{03RiskEE} \cdot (\overline{Q33i} + \overline{Q61ai} + \overline{Q61bi}) ;$$

$$[5k] \quad \mathcal{K}_{03RiskEE} = (0,565 + 0,766 + 0,847)^{-1} = 0,459$$

$$[6] \quad \Phi_{04WPWP} = \mathcal{K}_{04WPWP} \cdot (\overline{Q46i} + \overline{Q51i}) ;$$

$$[6k] \quad \mathcal{K}_{04WPWP} = (0,816 + 0,756)^{-1} = 0,636$$

$$[7] \quad \Phi_{05DLJC} = \mathcal{K}_{05DLJC} \cdot (\overline{Q49ai} + \overline{Q49bi}) ;$$

$$[7k] \quad \mathcal{K}_{05DLJC} = (0,906 + 0,909)^{-1} = 0,550$$

$$[8] \quad \Phi_{06WMJC} = \mathcal{K}_{06WMJC} \cdot (\overline{Q61hi} + \overline{Q61ji} + \overline{Q61ki} + \overline{Q61li}) ;$$

$$[8k] \quad \mathcal{K}_{06WMJC} = (0,814 + 0,773 + 0,616 + 0,760)^{-1} = 0,337$$

$$[9] \quad \Phi_{07WCC} = \mathcal{K}_{07WCC} \cdot (\overline{Q61ci} + \overline{Q61di} + \overline{Q61ei} + \overline{Q61fi} + \overline{Q61ii} + \overline{Q61ni}) ;$$

$$[9k] \quad \mathcal{K}_{07WCC} = (0,738 + 0,765 + 0,603 + 0,510 + 0,781 + 0,808)^{-1} = 0,200$$

$$[10] \quad \Phi_{08OROC} = \mathcal{K}_{08OROC} \cdot (\overline{Q70ai} + \overline{Q70bi} + \overline{Q70ci} + \overline{Q70di} + \overline{Q70ei} + \overline{Q70fi} + \overline{Q89di} + \overline{Q89ei}) ;$$

$$[10k] \quad \mathcal{K}_{08OROC} = (0,757 + 0,740 + 0,785 + 0,740 + 0,652 + 0,783 + 0,537 + 0,708)^{-1} = 0,175$$

$$[11] \quad \Phi_{10SITCD} = \mathcal{K}_{10SITCD} \cdot (\overline{Q89ai} + \overline{Q89bi} + \overline{Q89ci}) ;$$

$$[11k] \quad \mathcal{K}_{10SITCD} = (0,807 + 0,713 + 0,867)^{-1} = 0,418$$

Efectos directos en los compuestos endógenos

$$[12] \quad \gamma_{12NO \text{ direct}} = (-0,298 \cdot \xi_{11PO} + 0,212 \cdot \psi_{01WH} + 0,204 \cdot \psi_{02EE} - 0,016 \cdot \phi_{03RiskEE} + 0,219 \cdot \phi_{04WPWP} + 0,151 \cdot \phi_{05DLJC} - 0,027 \cdot \phi_{06WMJC} + 0,100 \cdot \phi_{07WCC} - 0,027 \cdot \phi_{08OROC} + 0,012 \cdot \phi_{10SITCD})$$

$$[13] \quad \gamma_{11PO \text{ direct}} = (-0,136 \cdot \psi_{01WH} + 0,041 \cdot \phi_{03RiskEE} + 0,239 \cdot \phi_{06WMJC} + 0,060 \cdot \phi_{07WCC} + 0,197 \cdot \phi_{08OROC} + 0,260 \cdot \phi_{10SITCD})$$

Efectos indirectos en la variable endógena final

$$[14] \quad \zeta_{12NO \text{ indirect}} = (-0,013 \cdot \phi_{03RiskEE} - 0,070 \cdot \phi_{06WMJC} - 0,020 \cdot \phi_{07WCC} - 0,056 \cdot \phi_{08OROC} - 0,077 \cdot \phi_{10SITCD})$$

Efectos totales en la variable endógena final

$$[15] \quad \ddot{I}_{12NO \text{ Total}} = \gamma_{12NO \text{ direct}} + \zeta_{12NO \text{ indirect}}$$

Para facilitar la manipulación de ecuaciones, presentamos las ecuaciones principales según su codificación numérica:

$$\ddot{I}_{12NO \text{ Total}} [15] = [12] + [14]$$

$$\gamma_{12NO \text{ direct}} [12] = -0,298.[2] + 0,212.[3] + 0,204.[4] - 0,016.[5] + 0,219.[6] + 0,151.[7] - 0,027.[8] + 0,1.[9] - 0,027.[10] + 0,012.[11]$$

$$\zeta_{12NO \text{ indirect}} [14] = -0,013.[5] - 0,07.[8] - 0,02.[9] - 0,056.[10] - 0,077.[11]$$

El conjunto de ecuaciones desarrollado a partir del modelo **V01A** permite:

1. Determinar la medida general de efectos negativos de las condiciones de trabajo sobre el trabajador, en el conjunto de los 35 Estados que componen la encuesta, el indicador sintético pretendido [15];
2. Determinar el resumen de los efectos negativos directos {[12] + [13]} e indirectos [14] de las condiciones de trabajo sobre el trabajador, en el conjunto de países participantes en la encuesta;
3. Determinar los efectos positivos [13] de las condiciones de trabajo sobre el trabajador, en el conjunto de países participantes en la encuesta;
4. Calcular la relación de efectividad predictiva (repercusión de las variables exógenas) en cuanto a efectos positivos producidos [13] / [2];
5. Calcular la relación de efectividad predictiva (repercusión de las variables exógenas) en cuanto a efectos generales producidos [15] / [1];
6. Construir un índice general;
7. Construir un ranking por países, que refleje la situación a la fecha de recogida de los datos. (hay tres soluciones: (a) necesita de análisis multigrupo vía PLS; (b) otra solución

sería la fragmentación de la base de datos en 35 bloques, cada uno correspondiente a un país, y a partir de ahí proceder a todos los análisis de validación; (c) la tercera, es una versión genérica que parece ser la utilizada en estudios anteriores. Resulta que la aplicación del modelo en cada tramo de datos, a que corresponderá cada país, seguro que va a generar valores de regresiones distintos, lo cual tiene todo el sentido. Esta tercera solución, al presuponer el mantenimiento de las regresiones, solo cambiando los datos de las cuestiones por país, podrá conducir a estimaciones erróneas en cuanto al índice. Queda aquí registrada nuestra posición).

8.8.1 Creación del índice general – INDEX V01A

Este índice es absolutamente necesario para interpretar un valor obtenido a partir de [15].

Para este efecto, hay que producir simulaciones con los extremos de las escalas, logrando obtenerse las dimensiones máxima y mínima de los efectos. De ahí se atribuye un score para cada medida extrema [0,100 ; 1,000], proporcionando un intervalo en el cual cualquier país o región tendrá su resultado después de la conversión iterativa de la medida obtenida. Para determinar el máximo valor y su opuesto, el mínimo que pueden ocurrir por aplicación de las ecuaciones, hay que coger el sentido positivo o negativo de la cuestión, y si la escala utilizada para nuestro trabajo es en modo directo o reverso. La lógica es la siguiente: para el valor máximo obtenible impactan los valores de las escalas de las cuestiones (según el modo directo o reverso utilizado) que más influencia tendrán en el aumento de las condiciones negativas, por lo que las cuestiones con sentido positivo se integran con su valor mínimo de escala; Para el valor mínimo es aplicable el racional opuesto.

Para obtenerse los extremos de la ecuación de efectos totales (valores MAX y MIN), desarrollamos una hoja en Excel llamada MEAN, en la cual, a partir de los datos ya tratados (escalas correctas de hecho utilizadas en nuestros análisis, sin valores omisos) y según las cuestiones efectivamente consideradas, son registradas las amplitudes de cada escala perteneciente a una misma cuestión. A continuación, se analiza el sentido general positivo o negativo de cada cuestión involucrada en los cálculos, y por fin son considerados los límites de cada escala perteneciente a cada cuestión para efectos de su involucración en la definición de los límites máximo y mínimo que pueden existir para los efectos totales. En este modelo **V01A** resultante de nuestro estudio, el valor máximo obtenible (o sea, la puntuación máxima de efectos negativos que resulta de las condiciones exógenas que actúan) es de **8,786** y, la puntuación mínima, de **-5,747**. La interpretación de estos extremos es perfectamente intuitiva. El indicador final (12_Negative_Outcomes) deberá, en condiciones extremas de negatividad y mínimas de positividad, generar un valor positivo que es 8,786. El opuesto, cuando ocurran condiciones mínimas de negatividad, los efectos positivos van en contra los efectos negativos y los superan, por lo que el valor final de efectos totales en estas condiciones tiene que ser negativo, asumiendo el límite de -5,747.

Los cálculos para llegar al valor final del modelo, y para determinar el máximo y mínimo de las ecuaciones estructurales fueron hechos en hoja de Excel. El fichero que agrega esos cálculos e variada información referente a la aplicación del PLS es: **PLS-analisis 05-2020-29A**. La hoja que sirve para el cálculo del valor se llama **Mean**. La hoja destinada al cálculo de los valores máximo y mínimo se llama **MaxMin**.

Al considerarse las puntuaciones para cada cuestión (¡ojo! puntuaciones esas ya convertidas según el modo reverso o directo para cada escala, o sea, ya tratadas), se obtiene el valor general de efectos totales por aplicación de las ecuaciones estructurales. La hoja de cálculo MEAN fue utilizada para extraer la media en cada cuestión (condición indispensable para que se produzcan los cálculos). Con esa media/cuestión la hoja hace los cálculos para cada bloque de ecuaciones y determina el valor final, que es de **-1,52144**.

A partir de ahí se va a calcular el valor correspondiente en el índice, lo cual posee como extremos [0,100 ; 1,000].

En cuanto a la conversión al índice de la medida general obtenida, se aplica el **LIM** – Linear Iteration Method. **Y** es el valor a determinar para efectos de índice, **X** es el valor obtenido por aplicación de las ecuaciones estructurales, **X1** es el valor máximo obtenible para efectos de impacto negativo de las condiciones de trabajo en el trabajador (8,786), **X2** corresponde al valor mínimo obtenible en términos de impacto (-5,747), y la formulación iterativa se presenta abajo. Por cuestiones de agilización operativa presentamos la fórmula simplificada, correspondiente al modelo estructural estudiado.

$$Y = ?$$

$$X = \text{valor}$$

$$X1 = 8,786$$

$$Y1 = 1,000$$

$$X2 = -5,747$$

$$Y2 = 0,100$$

$$Y = (((X - X1)(Y2 - Y1)) / (X2 - X1)) + Y1 = 0,362$$

$$Y = 0,062X + 0,456$$

8.8.2 Medida de los efectos negativos e interpretación

El valor obtenido proveniente del cálculo de los efectos producidos en el modelo es **-1,52144188**. Por su conversión para el índice se obtiene **0,362**. Significa que en términos del ranking de la escala [0,100 ; 1,000] y en términos generales en cuanto al agregado de los 35 países participantes, los efectos de las condiciones a vigorar (2015) en términos negativos están

por debajo del punto neutro (**0,45**), o sea, las condiciones generales benefician superlativamente en cuanto a impactos positivos, los cuales superan los efectos negativos.

8.8.3 Rango por Países

La tabla indexada de rango por países es presentada a continuación. Se señala la posición de España y del agregado de los 35 países. Su construcción está comprobada en la hoja **Values** (a partir de la columna FP) y en la hoja **Country Rank**, las dos pertenecen al fichero **PLS-analisis 05-2020-29A**, anteriormente mencionado.

NEGATIVE EFFECTS OF WORK CONDITIONS ON PEOPLE			
COUNT	CODE	COUNTRY	INDEX
1	35	ALBANIA	0,40650
2	32	TURKEY	0,38866
3	31	SERBIA	0,38331
4	29	MONTENEGRO	0,37960
5	5	CYPRUS	0,37780
6	10	FRANCE	0,37774
7	23	ROMANIA	0,37451
8	28	UK	0,37303
9	26	SPAIN	0,37295
10	4	CROATIA	0,37280
11	19	MALTA	0,36764
12	27	SWEDEN	0,36698
13	18	LUXEMBOURG	0,36618
14	25	SLOVENIA	0,36537
15	30	FYROM	0,36520
16	12	GREECE	0,36205
17	36	AGGREGATE 35	0,36200
18	15	ITALY	0,36079
19	24	SLOVAKIA	0,36061
20	34	SWITZERLAND	0,36044
21	9	FINLAND	0,35968
22	22	PORTUGAL	0,35862
23	33	NORWAY	0,35777
24	21	POLAND	0,35730
25	1	AUSTRIA	0,35553
26	16	LATVIA	0,35403
27	7	DENMARK	0,35268
28	13	HUNGARY	0,35239
29	14	IRELAND	0,35095
30	8	ESTONIA	0,35025
31	17	LITHUANIA	0,34928
32	6	CZECH REPUBLIC	0,34833
33	20	NETHERLANDS	0,34682
34	2	BELGIUM	0,34677
35	11	GERMANY	0,34242
36	3	BULGARIA	0,33391
		MEAN	0,36283
		MEDIAN	0,36061
		STD	0,014480394

Tabla LXIV

Presentamos dos gráficos, el primero ordenado por código de país, y el siguiente por valor de los efectos.



Figura 32



Figura 33

TABLAS

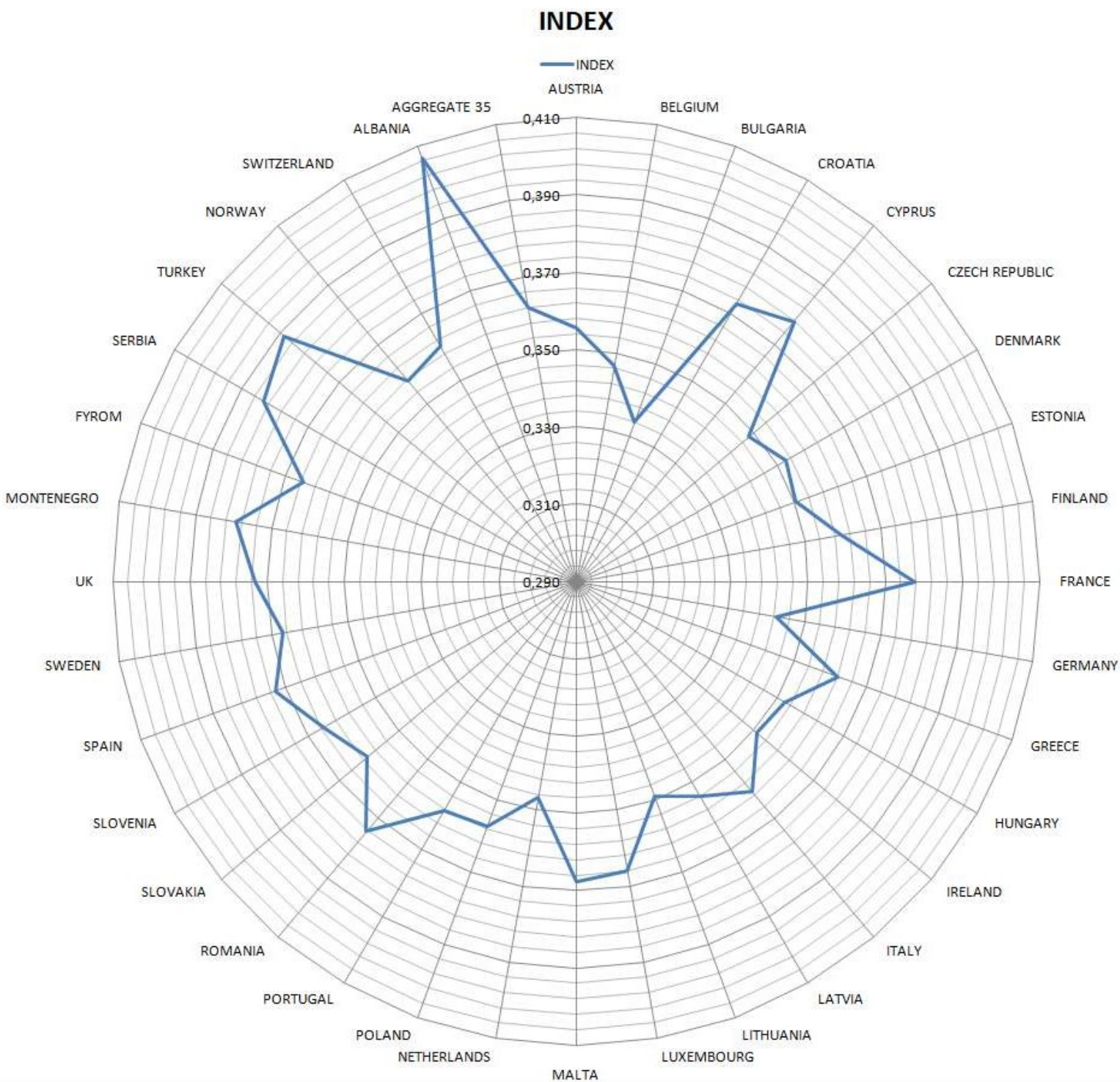
Tabla 1. Transformaciones y Z-Scores

Nombre Variable	Skewness	Kurtosis	Mahlanobis Nº registros Pvalue<0,001	Transform						Z-Score		Obrvaciones
				LG ₁₀ Skewness	LG ₁₀ Kurtosis	SQR Skewness	SQR Kurtosis3	REVERSE Skewness	REVERSE Kurtosis	Lower limit	Upper limit	
Q18a_inv_LD	0,814	3,589	528	-1,442	10,263	-0,12	5,174	4,984	36,403	-3,602 ¹	3,069	Original
Q18b_inv_LD	-0,276	1,348	515	-1,887	7,015	-0,978	3,203	4,097	21,273	-3,269 ¹	2,623	Original
Q18c_inv_LD	1,000	2,699	568	-0,87	8,934	0,282	4,035	4,959	44,078	-3,702 ¹	2,937	Original
Q18d_inv_LD	0,812	0,528	-	-	-	-	-	-	-	-3,489 ¹	2,281	Original
Q29f_inv_LD	3,135	10,135	1961	2,046	3,306	2,525	6,11	-1,538	0,716	-2,733	0,522	Sobre REVERSE
Q29g_inv_LD	2,447	5,418	2162	1,605	1,361	1,986	3,081	-1,171	-0,353	-2,280	0,607	Sobre REVERSE
Q29h_inv_LD	3,268	11,293	2109	2,108	3,657	2,613	6,746	-1,585	0,879	-2,824	0,512	Sobre REVERSE
Q29i_inv_LD	2,729	6,763	2209	1,944	2,572	2,307	4,418	-1,510	0,578	-2,526	0,526	Sobre REVERSE
Q30a_inv_LD	0,847	-0,528	-	-	-	-	-	-	-	-0,931	2,181	Original
Q30b_inv_LD	3,242	9,930	20	2,473	4,988	2,831	7,194	-2,039	2,497	-2,983	0,429	Sobre REVERSE
Q30c_inv_LD	1,476	1,247	727	0,697	-0,861	1,058	0,011	-0,257	-1,677	-0,866	2,138	Sobre LOG ₁₀
Q30d_inv_LD	0,199	-1,426	841	-0,379	-1,293	-0,077	-1,429	0,900	-0,808	-0,906	1,714	Sobre REVERSE
Q29a_inv_LD	2,017	2,958	1647	1,384	0,486	1,682	1,581	-1,011	0,744	-2,036	0,650	Sobre REVERSE
Q29b_inv_LD	1,472	1,089	1806	0,773	-0,813	1,101	-0,007	-0,360	-1,626	-0,823	2,123	Sobre LOG ₁₀
Q29c_inv_LD	1,739	2,317	1635	0,957	-0,443	1,303	0,653	-0,564	-1,448	-0,748	2,442	Sobre LOG ₁₀
Q29d_inv_LD	1,941	3,469	1627	1,071	-0,149	1,440	1,213	-0,681	-1,300	-0,709	2,698	Sobre LOG ₁₀
Q29e_inv_LD	2,521	5,590	1413	1,766	1,850	2,114	3,483	1,35	0,099	-2,377	0,561	Sobre REVERSE
Q30e_inv_LD	0,091	-1,512	173	-0,418	-1,373	-0,158	-1,492	0,835	-1,027	-0,879	1,621	Sobre REVERSE
Q30f_inv_LD	-0,066	-1,641	168	-0,505	-1,340	-0,272	-1,529	0,906	-0,914	-0,813	1,669	Sobre REVERSE
Q30g_inv_LD	1,158	0,277	97	0,311	-1,073	0,738	-0,518	0,313	-1,484	-1,028	2,133	Sobre SQR
Q30h_inv_LD	1,301	1,080	81	0,341	-0,992	0,792	-0,203	0,237	-1,564	-1,007	2,545	Sobre SQR
Q30i_inv_LD	0,197	-1,604	151	-0,227	-1,591	-0,008	-1,622	0,572	-1,468	-0,933	1,411	Sobre REVERSE
Q33_rect	0,920	0,955	4	0,162	-1,170	0,471	-0,414	0,145	-1,743	-1,039	2,773	Sobre SQR
Q40_inv	1,538	2,431	1058	0,824	-0,626	1,108	0,447	-0,544	-1,495	-0,768	2,991	Sobre LOG ₁₀
Q43_inv	1,763	-1,533	18	0,331	-1,754	0,312	-1,415	-0,220	-1,887	-2,616	1,365	Sobre SQR
Q44_rect	0,740	0,319	-	-	-	-	-	-	-	-1,236	2,819	Original
Q45a_inv	0,532	-0,581	-	-	-	-	-	-	-	-1,096	2,420	Original
Q45b_inv	0,070	-0,653	-	-	-	-	-	-	-	-1,515	2,087	Original
Q45c_inv	0,656	-0,441	-	-	-	-	-	-	-	-1,012	2,600	Original
Q45d_inv	1,030	0,499	203	0,446	-1,240	0,687	-0,628	-0,179	-1,763	-0,884	3,043	Sobre SQR
Q45e_inv	1,378	1,481	108	0,773	-0,819	1,019	0,007	-0,512	-1,539	-0,780	2,759	Sobre LOG ₁₀
Q46_inv	1,363	1,168	888	0,727	-0,857	1,002	-0,071	-0,413	-1,601	-0,816	2,397	Sobre LOG ₁₀
Q47_rect	0,348	-0,875	-	-	-	-	-	-	-	-1,315	1,736	Original
Q49a_inv	0,240	-1,246	95	-0,448	-1,067	-0,089	-1,266	1,088	-0,286	-1,654	1,286	Sobre LOG ₁₀
Q49b_inv	0,214	-1,279	0	-	-	-	-	-	-	-1,325	1,623	Original
Q51_inv	0,453	-0,522	-	-	-	-	-	-	-	-1,353	1,955	Original
Q61a_inv	-1,149	1,138	919	-2,345	6,460	-1,673	3,176	3,861	15,926	-3,095	0,951	Original
Q61b_inv	-0,788	0,014	-	-	-	-	-	-	-	-2,388	1,060	Original
Q61c_inv	-0,240	-1,179	996	-0,824	-0,670	-0,535	-0,978	1,269	-0,014	-1,809	1,049	Sobre LOG ₁₀
Q61d_inv	-0,236	-1,184	996	-0,818	-0,693	-0,532	0,989	1,252	-0,074	-1,794	1,045	Sobre LOG ₁₀
Q61e_inv	0,700	-0,917	-	-	-	-	-	-	-	-0,897	1,923	Original
Q61f_inv	-0,104	-1,280	1019	-0,680	-0,878	-0,390	-1,139	1,152	-0,256	-1,601	1,233	Sobre SQR
Q61g_inv	-0,922	0,503	-	-	-	-	-	-	-	-2,956	1,078	Original
Q61h_inv	-1,178	1,459	835	-2,505	8,590	-1,725	3,968	4,675	26,095	-3,550 ¹	0,924	Original
Q61i_inv	-0,439	-0,836	-	-	-	-	-	-	-	-1,873	1,227	Original
Q61j_inv	-1,476	2,256	855	-2,812	10,470	-2,020	5,180	5,041	30,032	-3,813 ¹	0,765	Original
Q61k_inv	-2,191	5,889	807	-3,879	20,301	-2,868	11,045	6,731	53,593	-4,939 ¹	0,578	Original
Q61l_inv	-1,341	1,910	823	-2,663	8,988	-1,903	4,535	4,554	23,420	-3,523 ¹	0,868	Original
Q61m_inv	0,070	-0,558	-	-	-	-	-	-	-	-1,678	1,845	Original
Q61n_inv	0,014	-0,989	-	-	-	-	-	-	-	-1,654	1,426	Original
Q61o_inv	0,111	-1,227	1007	-0,449	-1,239	-0,181	-1,286	0,829	-1,026	-0,957	1,610	Sobre REVERSE
Q63a_inv	-1,649	2,499	800	-2,761	9,085	-2,115	4,925	4,611	24,868	-3,694 ¹	0,695	Original
Q63b_inv	-0,896	-0,069	-	-	-	-	-	-	-	-2,394	0,998	Original
Q63c_inv	-0,888	0,009	-	-	-	-	-	-	-	-2,561	1,013	Original
Q63d_inv	-0,703	-0,581	-	-	-	-	-	-	-	-2,087	1,064	Original
Q63e_inv	-0,876	-0,071	-	-	-	-	-	-	-	-2,428	1,017	Original
Q63f_inv	-0,818	-0,216	-	-	-	-	-	-	-	-2,376	1,019	Original
Q70a_inv	-1,004	0,586	1107	-2,051	4,469	-1,475	2,094	3,304	11,197	-2,776	1,039	Original
Q70b_inv	-1,274	1,785	963	-2,592	8,713	-1,834	4,313	4,562	24,104	-3,533 ¹	0,920	Original
Q70c_inv	-0,963	0,577	-	-	-	-	-	-	-	-2,823	1,081	Original
Q70d_inv	-0,980	0,486	-	-	-	-	-	-	-	-2,766	1,054	Original
Q70e_inv	-1,381	2,603	1061	-2,929	13,575	-1,986	6,217	6,117	49,485	-4,449 ¹	0,831	Original
Q70f_inv	-0,907	0,237	-	-	-	-	-	-	-	-2,608	1,077	Original
Q79a_inv	1,056	0,246	150	0,409	-1,193	0,701	-0,625	-0,045	-1,732	-0,924	2,379	Sobre SQR
Q79b_inv	0,899	-0,286	-	-	-	-	-	-	-	-0,898	2,353	Original
Q79c_inv	0,868	-0,210	-	-	-	-	-	-	-	-0,936	2,498	Original

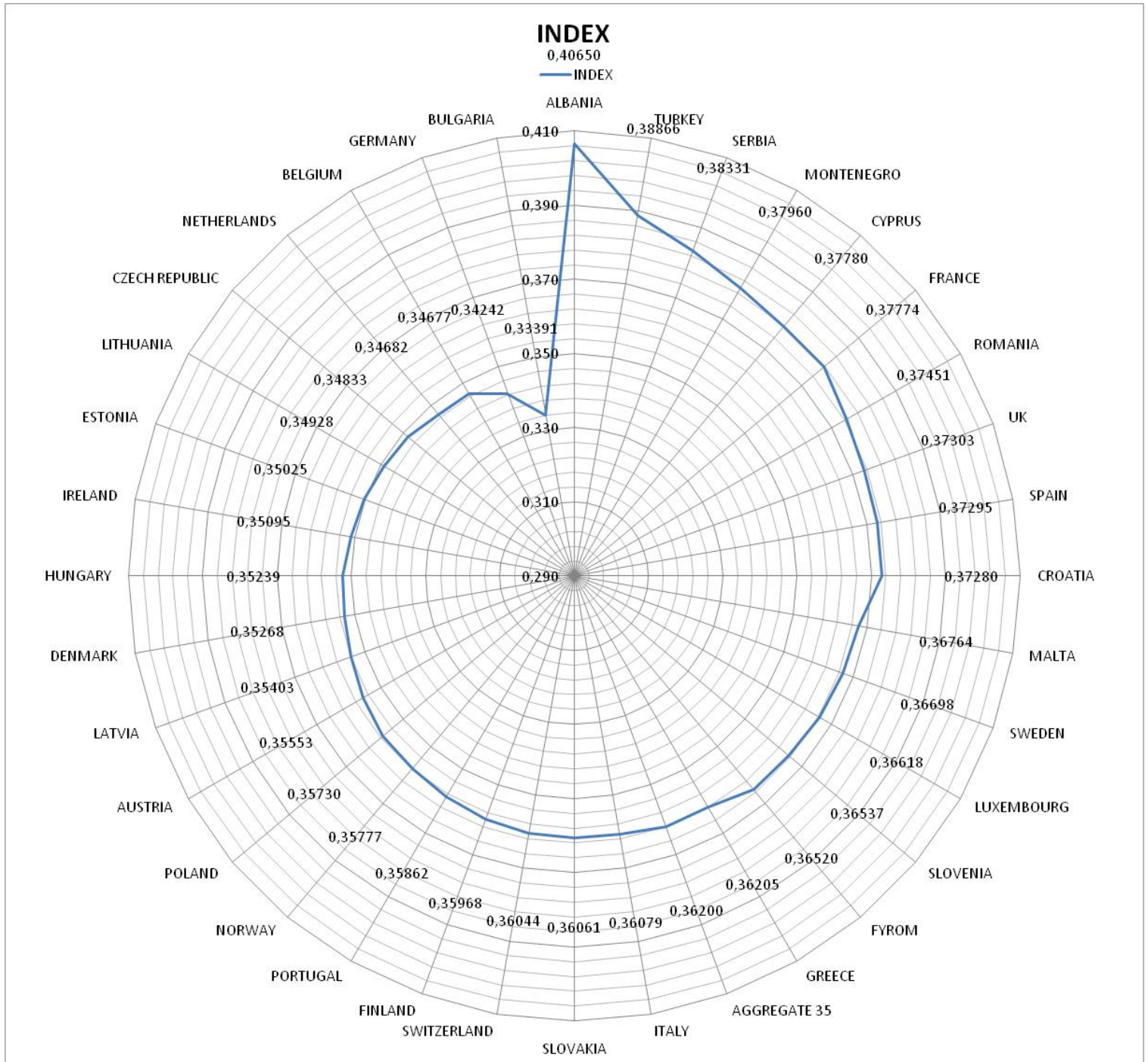
Tabla 1 (continuación)

Nombre Variable	Skewness	Kurtosis	Mahalanobis Nº registros Pvalue<0,001	Transform						Z-Score		Observaciones
				LG ₁₀ Skewness	LG ₁₀ Kurtosis	SQR Skewness	SQR Kurtosis3	REVERSE Skewness	REVERSE Kurtosis	Lower limit	Upper limit	
Q87a_inv	-1,035	0,967	678	-2,151	5,839	-1,516	2,613	4,187	22,722	-3,315 ¹	1,286	Original
Q87b_inv	-0,858	0,219	-	-	-	-	-	-	-	-2,761	1,311	Original
Q87c_inv	-0,915	0,471	-	-	-	-	-	-	-	-2,912	1,293	Original
Q87d_inv	-0,769	-0,124	-	-	-	-	-	-	-	-2,464	1,340	Original
Q87e_inv	-0,922	0,408	-	-	-	-	-	-	-	-2,955	1,227	Original
Q88_inv	-0,567	0,764	-	-	-	-	-	-	-	-3,051	1,362	Original
Q89a_inv	-0,349	-1,032	406	-0,986	-0,177	-0,659	-0,709	1,577	1,135	-2,074	1,062	Sobre LOG ₁₀
Q89b_inv	-0,073	-1,148	459	-0,689	-0,831	-0,387	-1,059	1,155	-0,259	-1,731	1,189	Sobre LOG ₁₀
Q89c_inv	-0,739	-0,214	-	-	-	-	-	-	-	-2,270	1,190	Original
Q89d_inv	-1,567	3,479	277	-3,262	16,803	-2,223	7,880	6,713	58,538	-4,780 ¹	0,762	Original
Q89e_inv	-0,724	-0,171	-	-	-	-	-	-	-	-2,327	1,193	Original
Q89f_inv	-1,667	3,350	383	-2,780	7,767	-2,237	5,346	3,620	12,338	-3,238	1,385	Original
Q89g_inv	0,987	-0,090	-	-	-	-	-	-	-	-0,864	2,405	Original
Q89h_inv	0,111	-1,223	470	-0,438	-1,255	-0,176	-1,296	0,814	-1,046	-0,975	1,602	Sobre REVERSE
Q90a_inv	-0,715	0,856	411	-2,014	6,540	-1,260	2,699	4,320	24,922	-3,421 ¹	1,442	Original
Q90b_inv	-0,794	0,449	-	-	-	-	-	-	-	-2,980	1,203	Original
Q90c_inv	-0,919	0,689	418	-2,134	6,831	-1,406	2,717	4,495	26,432	-3,451 ¹	1,015	Original
Q90d_inv	-0,006	-0,405	-	-	-	-	-	-	-	-2,082	1,767	Original
Q90e_inv	1,166	0,593	541	0,508	-1,108	0,799	-0,446	-0,163	-1,725	-0,874	2,509	Sobre SQR
Q90f_inv	-1,064	2,156	403	-2,728	16,125	-1,663	6,225	7,436	86,026	-5,220	0,915	Original
Q100_inv	-0,159	-0,451	-	-	-	-	-	-	-	-2,273	1,727	Original

¹ Out of bounds, presence of outliers

Tabla 2. PCA variables escala

Question	Variables	Variables deleted Groups Comments	α		Total variance explained	Nr. Factors	Confirm. Parallel Analysis	Correlation Matrix ≤	Pattern Matrix			
			Cronbach	Test KMO					Factor 1	Factor 2	Factor 3	Factor 4
Q18	TOTAL		0,658	0,646	49,825%	1	Y	-				
	Q18a_inv_LD								0,660*			
	Q18b_inv_LD								0,606*			
	Q18c_inv_LD								0,762*			
	Q18d_inv_LD								0,781*			
Q29	TOTAL		0,821	0,856	55,521%	2	Y	0,465				
	SMEAN (Q29a_inv_ReplaceMD)								0,773			
	SMEAN (Q29b_inv_ReplaceMD)								0,799			
	SMEAN (Q29c_inv_ReplaceMD)								0,734			
	SMEAN (Q29d_inv_ReplaceMD)								0,715			
	SMEAN (Q29e_inv_ReplaceMD)								0,682			
	Q29f_inv_LD									0,627		
	Q29g_inv_LD									0,839		
	Q29h_inv_LD								0,479			
	Q29i_inv_LD									0,874		
Q30	TOTAL		0,614	0,589	68,511%	2	Y	0,162				
	Q30a_inv_LD	-										
	Q30b_inv_LD	-										
	Q30c_inv_LD	-										
	Q30d_inv_LD									0,905		
	SMEAN(Q30e_inv)	-										
	SMEAN(Q30f_inv)								0,760			
	SMEAN (Q30g_inv_ReplaceMD)								0,851			
	SMEAN (Q30h_inv_ReplaceMD)								0,732			
	SMEAN (Q30i_inv_ReplaceMD)									0,869		
Q33 ⁵	TOTAL		0,721	0,804	58,764%	4	Y	0,461				
	Q33_rect_inv										0,442	
	Q61a_inv										0,848	
	Q61b_inv										0,851	
	1							1	1			1
Q40 ⁵	TOTAL	(Workload/Workpace)	0,359	0,500	61,319%	1	y	-				
	Q40_inv								0,783*			
	Q46_inv								0,783*			
Q43 ⁵	TOTAL	(Control)	0,610	0,714	53,689%	2	Y	0,203				
	Q43_inv									0,746		
	Q51_inv									0,769		
	Q61c_inv							2				
	Q61d_inv							2				
	Q61e_inv							2				
	Q61f_inv							2				
	Q61g_inv	-										
Q44 ⁵	TOTAL	(Home-Work interface)	0,375	0,646	50,669%	2	Y	-0,043				
	Q44_rect									0,715		
	Q18a_inv_LD							3				
	Q18b_inv_LD							3				
	Q18c_inv_LD							3				
	Q18d_inv_LD							3				
	Q47_rect									0,720		
	Q100									0,617		
Q45	TOTAL		0,758	0,774	51,916%	1	Y	-				
	Q45a_inv								0,626*			
	Q45b_inv								0,678*			
	Q45c_inv								0,788*			
	Q45d_inv								0,765*			
	Q45e_inv								0,734*			
Q46 ⁵	TOTAL	(already studied, see Q40_inv)										
Q47 ⁵	TOTAL	(already studied, see Q44_rect)										
Q49	TOTAL		0,787	0,500	82,414%	1	Y	-				
	Q49a_inv								0,908*			
	Q49b_inv								0,908*			
Q51 ⁵	TOTAL	(already studied, see Q43_inv)										

Tabla 2 (continuación)

Question	Variables	Variables deleted Groups Comments	α Cronbach	Test KMO	Total variance explained	Nr. Factors	Confirm. Parallel Analysis	Correlation Matrix ≤	Pattern Matrix			
									Factor 1	Factor 2	Factor 3	Factor 4
Q61	TOTAL		0,819	0,868	55,284%	3	Y	0,383				
	Q61a_inv										0,898	
	Q61b_inv										0,832	
	Q61c_inv								0,654			
	Q61d_inv								0,740			
	Q61e_inv								0,712			
	Q61f_inv								0,574			
	Q61g_inv									0,602		
	Q61h_inv									0,771		
	Q61i_inv								0,738			
	Q61j_inv									0,755		
	Q61k_inv									0,767		
	Q61l_inv									0,543		
	Q61m_inv	-										
	Q61n_inv								0,814			
	Q61o_inv	-										
Q61	Q61m_inv	Variable individual (Results)										
	Q61a,b	(Environment & Equipment)	0,699	0,500	77,230%	1	Y	-				
	Q61a_inv								0,879*			
	Q61b_inv								0,879*			
	Q61c,d,e,f,g	(Control/Organization)	0,669	0,712	50,553%	1	Y	-				
	Q61c_inv								0,761*			
	Q61d_inv								0,773*			
	Q61e_inv								0,718*			
	Q61f_inv								0,573*			
	Q61g_inv	-										
	Q61h,i,j,k	(Job content/Satisfaction W/work)	0,646	0,702	51,971%	1	Y	-				
	Q61h_inv								0,821*			
	Q61i_inv								0,549*			
	Q61j_inv								0,815*			
	Q61k_inv								0,662*			
	Q61l,n,o	(Organiz. Culture/Fair deal)	0,395	0,500	63,099%	1	Y	-				
	Q61l_inv								0,794*			
	Q61n_inv								0,794*			
	Q61o_inv	-										
Q63	TOTAL		0,894	0,909	65,771%	1	Y	-				
	Q63a_inv								0,763*			
	Q63b_inv								0,823*			
	Q63c_inv								0,809*			
	Q63d_inv								0,767*			
	Q63e_inv								0,837*			
	Q63f_inv								0,862*			
Q70	TOTAL		0,856	0,885	58,304%	1	Y	-				
	Q70a_inv								0,771*			
	Q70b_inv								0,765*			
	Q70c_inv								0,815*			
	Q70d_inv								0,766*			
	Q70e_inv								0,637*			
	Q70f_inv								0,814*			
Q79	TOTAL		0,808	0,712	72,314%	1	Y	-				
	Q79a_inv								0,855*			
	Q79b_inv								0,861*			
	Q79c_inv								0,834*			
Q87	TOTAL		0,879	0,869	67,843%	1	Y	-				
	Q87a_inv								0,846*			
	Q87b_inv								0,835*			
	Q87c_inv								0,856*			
	Q87d_inv								0,818*			
	Q87e_inv								0,759*			
Q88 ⁵	TOTAL	(Results)	0,707	0,882	61,612%	3	Y	0,474			0,525	
	Q88_inv											
	Q45a_inv									4		
	Q45c_inv									4		
	Q45d_inv									4		
	Q45e_inv									4		
	Q87a_inv								4			
	Q87b_inv								4			
	Q87c_inv								4			
	Q87d_inv								4			
	Q87e_inv								4			
	Q90a_inv										0,643	
	Q90b_inv										0,825	
	Q90c_inv										0,813	

Tabla 2 (continuación)

Question	Variables	Variables deleted Groups Comments	α		Total variance explained	Nr. Factors	Confirm. Parallel Analysis	Correlation Matrix \leq	Pattern Matrix			
			Cronbach	Test KMO					Factor 1	Factor 2	Factor 3	Factor 4
Q89	TOTAL		0,739	0,795	52,269%	1	Y	-				
	Q89a_inv								0,741*			
	Q89b_inv								0,689*			
	Q89c_inv								0,834*			
	Q89d_inv								0,473*			
	Q89e_inv								0,818*			
	Q89f_inv	-										
	Q89g_inv	-										
	Q89h_inv	-										
Q89	Q89a,b,c	(Career Development/Present Sit.)	0,713	0,666	63,972%	1	Y	-				
	Q89a_inv								0,814*			
	Q89b_inv								0,753*			
	Q89c_inv								0,831*			
	Q89d,e,g	(Organiz.Culture/Situation)	0,441	0,500	65,627%	1	Y	-				
	Q89d_inv								0,810*			
	Q89e_inv								0,810*			
	Q89g_inv	-										
Q90	TOTAL		0,712	0,720	53,820%	1	Y	-				
	Q90a_inv								0,801*			
	Q90b_inv								0,804*			
	Q90c_inv								0,732*			
	Q90d_inv	-										
	Q90e_inv	-										
	Q90f_inv								0,573*			
Q90	Q90a,b,c	(Results/welfare)	0,725	0,664	64,848%	1	Y	-				
	Q90a_inv								0,831*			
	Q90b_inv								0,836*			
	Q90c_inv								0,746*			
	Q90e,f	(Career Development/Opinion)	NA**	NA**								
	Q90e_inv											
	Q90f_inv											
Q100 ⁵		(already studied Q100, see Q44_rect)										

* - Component Matrix values

** - Not used, tests off the threshold

¹ - Study generated 4 factors. Q33_rect_inv charges on the F3 with Q61a+Q61b

² - Q43 study generated 2 factors, relating F2 Q43+Q51; F1 aggregates all variables compound of Q61c,d,e,f, already studied as a single construct

³ - Study generated 2 factors. Q44_rect charges on the F2 with Q47_rect+Q100

⁴ - Study of Q88_inv generated 3 factors; The factor that matters is F3

⁵ - Variables that relate with others

Tabla 3. Variables nominales y ordinales

















































VARIABLES NOMINAL AND ORDINAL		SUMMARY VARIABLE	ORDINAL	Summary Var. *
NOMINAL				
 Q20_dic			 Q22_Rect	Rebuilt
 Q22_dummy1			 Q24_cat	Workload & workpace
Q22_dummy2			 Q26_cat	Workload & workpace
Q22_dummy3			 Q36_cat	Home – work interfece
 Q64_aRect	Career Development		 Q64_TOTAL	Career Development *
Q64_bRect	Career Development	 Q64_TOTAL	 Q65_TOTAL	Career Development *
Q64_cRect	Career Development		 Q42_TOTAL	Control *
 Q65a_dic_MV	Career Development		 Q50_TOTAL	Control *
Q65b_dic_MV	Career Development		 Q52_TOTAL	Control *
Q65c_dic_MV	Career Development		 Q54_TOTAL	Control *
Q65d_dic_MV	Career Development	 Q65_TOTAL	 Q72_TOTAL	Environment & equipment *
 Q42_dic1	Control		 Q80_TOTAL	Environment & equipment *
Q42_dic2	Control		 Q81_TOTAL	Environment & equipment *
Q42_dic3	Control		 Q23_cat	Job content
Q42_dic4	Control	 Q42_TOTAL	 Q48_TOTAL	Job content *
 Q50a_dic_MV	Control		 Q71_TOTAL	Organizational Culture *
Q50b_dic_MV	Control		 Q78_TOTAL	Resultados y efectos *
Q50c_dic_MV	Control			
Q50d_dic_MV	Control			
Q50e_dic_MV	Control	 Q50_TOTAL		
 Q52_dic1	Control			
Q52_dic2	Control			
Q52_dic3	Control	 Q52_TOTAL		
 Q54a_dic_MV	Control			
Q54b_dic_MV	Control			
Q54c_dic_MV	Control	 Q54_TOTAL		
 Q58_dic_MV	Control			
 Q31_dic_MV	Environment & equipment			
 Q34_dic_MV	Environment & equipment			
 Q72a_dic_MV	Environment & equipment			
Q72b_dic_MV	Environment & equipment			
Q72c_dic_MV	Environment & equipment			
Q72d_dic_MV	Environment & equipment			
Q72e_dic_MV	Environment & equipment			
Q72f_dic_MV	Environment & equipment			
Q72g_dic_MV	Environment & equipment	 Q72_TOTAL		
 Q73_dic_MV	Environment & equipment			
 Q80a_dic_MV	Environment & equipment			
Q80b_dic_MV	Environment & equipment			
Q80c_dic_MV	Environment & equipment			
Q80d_dic_MV	Environment & equipment	 Q80_TOTAL		
 Q81a_dic_MV	Environment & equipment			
Q81b_dic_MV	Environment & equipment			
Q81c_dic_MV	Environment & equipment	 Q81_TOTAL		
 Q27_dic_MV	Home – work interfece			
 Q48a_dic_MV	Job content			
Q48b_dic_MV	Job content	 Q48_TOTAL		
 Q53a_dic_MV	Job content			
Q53b_dic_MV	Job content			
Q53c_dic_MV	Job content			
Q53d_dic_MV	Job content			
Q53e_dic_MV	Job content			
Q53f_dic_MV	Job content			
 Q55_dic_MV	Job content			
 Q71a_dic_MV	Organizational Culture			
Q71b_dic_MV	Organizational Culture			
Q71c_dic_MV	Organizational Culture	 Q71_TOTAL		

Tabla 3 (continuación)





VARIABLES NOMINAL AND ORDINAL		SUMMARY VARIABLE	ORDINAL	Summary Var. *
NOMINAL				
 Q78a_dic_MV	Resultados y efectos			
Q78b_dic_MV	Resultados y efectos			
Q78c_dic_MV	Resultados y efectos			
Q78d_dic_MV	Resultados y efectos			
Q78e_dic_MV	Resultados y efectos			
Q78f_dic_MV	Resultados y efectos			
Q78g_dic_MV	Resultados y efectos			
Q78h_dic_MV	Resultados y efectos			
Q78i_dic_MV	Resultados y efectos	 Q78_TOTAL		
 Q37a_dic	Workload & workpace			
Q37b_dic	Workload & workpace			
Q37c_dic	Workload & workpace			
Q37d_dic	Workload & workpace			
 Q38_dic_inv	Workload & workpace			
 Q39a_dic	Workload & workpace			
Q39b_dic	Workload & workpace			
Q39c_dic	Workload & workpace			
Q39d_dic	Workload & workpace			
Q39e_dic	Workload & workpace			

Tabla 4. Relaciones entre variables nominales

Variable tested	Association with	Statistics p_{value} (2-sided)								Comments
		Pearson's χ^2		Likelihood Ratio		Fisher's Exact Test		Cramer's V		
		Sig	Non-sig.	Sig	Non-sig.	Sig	Non-sig.	Value	Sig	
Q20_dic	Q22_dummy1	0,536	-	-	-	-	-	-	-	Not associated, p_{value} exceeds 0,05 threshold
	Q22_dummy2	0,699	-	-	-	-	-	-	-	Not associated, p_{value} exceeds 0,05 threshold
	Q22_dummy3	0,167	-	-	-	-	-	-	-	Not associated, p_{value} exceeds 0,05 threshold
	Q64_aRect	0,000	-	-	-	-	-	0,070	0,000	Very low relation, Cramer almost null
	Q64_bRect	0,000	-	-	-	-	-	0,058	0,000	Very low relation, Cramer almost null
	Q64_cRect	0,078	-	-	-	-	-	-	-	Not associated, p_{value} exceeds 0,05 threshold
	Q65a_dic_MV	0,000	-	-	-	-	-	0,147	0,000	Low relation, Cramer less than 0,2
	Q65b_dic_MV	0,000	-	-	-	-	-	0,048	0,000	Very low relation, Cramer almost null
	Q65c_dic_MV	0,000	-	-	-	-	-	0,140	0,000	Low relation, Cramer less than 0,2
	Q65d_dic_MV	0,000	-	-	-	-	-	0,089	0,000	Very low relation, Cramer almost null
	Q42_dic1	0,000	-	-	-	-	-	0,113	0,000	Low relation, Cramer less than 0,2
	Q42_dic2	0,068	-	-	-	-	-	-	-	Not associated, p_{value} exceeds 0,05 threshold
	Q42_dic3	0,000	-	-	-	-	-	0,116	0,000	Low relation, Cramer less than 0,2
	Q42_dic4	0,000	-	-	-	-	-	0,022	0,000	Very low relation, Cramer almost null
	Q50a_dic_MV	0,000	-	-	-	-	-	0,076	0,000	Very low relation, Cramer almost null
	Q50b_dic_MV	0,000	-	-	-	-	-	0,056	0,000	Very low relation, Cramer almost null
	Q50c_dic_MV	0,000	-	-	-	-	-	0,094	0,000	Very low relation, Cramer almost null
	Q50d_dic_MV	0,035	-	-	-	-	-	0,012	0,035	Very low relation, Cramer almost null
	Q50e_dic_MV	0,554	-	-	-	-	-	-	-	Not associated, p_{value} exceeds 0,05 threshold
	Q52_dic1	0,000	-	-	-	-	-	0,167	0,000	Low relation, Cramer less than 0,2
	Q52_dic2	0,000	-	-	-	-	-	0,168	0,000	Low relation, Cramer less than 0,2
	Q52_dic3	0,001	-	-	-	-	-	0,018	0,000	Very low relation, Cramer almost null
	Q54a_dic_MV	0,000	-	-	-	-	-	0,080	0,000	Very low relation, Cramer almost null
	Q54b_dic_MV	0,000	-	-	-	-	-	0,061	0,000	Very low relation, Cramer almost null
	Q54c_dic_MV	0,000	-	-	-	-	-	0,030	0,000	Very low relation, Cramer almost null
	Q58_dic_MV	0,000	-	-	-	-	-	0,124	0,000	Low relation, Cramer less than 0,2
	Q31_dic_MV	0,000	-	-	-	-	-	0,038	0,000	Very low relation, Cramer almost null
	Q34_dic_MV	0,000	-	-	-	-	-	0,078	0,000	Very low relation, Cramer almost null
	Q72a_dic_MV	0,000	-	-	-	-	-	0,067	0,000	Very low relation, Cramer almost null
	Q72b_dic_MV	0,000	-	-	-	-	-	0,030	0,000	Very low relation, Cramer almost null
	Q72c_dic_MV	0,000	-	-	-	-	-	0,034	0,000	Very low relation, Cramer almost null
	Q72d_dic_MV	0,000	-	-	-	-	-	0,062	0,000	Very low relation, Cramer almost null
	Q72e_dic_MV	0,000	-	-	-	-	-	0,022	0,000	Very low relation, Cramer almost null
	Q72f_dic_MV	0,000	-	-	-	-	-	0,034	0,000	Very low relation, Cramer almost null
	Q72g_dic_MV	0,021	-	-	-	-	-	0,013	0,000	Very low relation, Cramer almost null
	Q73_dic_MV	0,000	-	-	-	-	-	0,086	0,000	Very low relation, Cramer almost null
	Q80a_dic_MV	0,000	-	-	-	-	-	0,104	0,000	Low relation, Cramer less than 0,2
	Q80b_dic_MV	-	-	-	0,000	-	-	0,037	0,000	Very low relation, Cramer almost null
	Q80c_dic_MV	-	-	-	0,000	-	-	0,106	0,000	Low relation, Cramer less than 0,2
	Q80d_dic_MV	-	-	-	0,000	-	-	0,081	0,000	Very low relation, Cramer almost null
Q81a_dic_MV	-	-	-	0,000	-	-	0,068	0,000	Very low relation, Cramer almost null	
Q81b_dic_MV	-	-	-	0,000	-	-	0,037	0,000	Very low relation, Cramer almost null	
Q81c_dic_MV	-	-	-	0,000	-	-	0,099	0,000	Very low relation, Cramer almost null	
Q27_dic_MV	-	-	-	0,000	-	-	0,035	0,000	Very low relation, Cramer almost null	
Q48a_dic_MV	0,493	-	-	-	-	-	-	-	Not associated, p_{value} exceeds 0,05 threshold	
Q48b_dic_MV	0,001	-	-	-	-	-	0,019	0,001	Very low relation, Cramer almost null	

Tabla 4 (continuación)









Variable tested	Association with	Statistics p_{value} (2-sided)								Comments
		Pearson's χ^2		Likelihood Ratio		Fisher's Exact Test		Cramer's V		
		Sig	Non-sig.	Sig	Non-sig.	Sig	Non-sig.	Value	Sig	
 (ídem)	 Q53a_dic_MV	0,000	-	-	-	-	-	0,056	0,000	Very low relation, Cramer almost null
	Q53b_dic_MV	0,000	-	-	-	-	-	0,085	0,000	Very low relation, Cramer almost null
	Q53c_dic_MV	0,000	-	-	-	-	-	0,094	0,000	Very low relation, Cramer almost null
	Q53d_dic_MV	0,000	-	-	-	-	-	0,024	0,000	Very low relation, Cramer almost null
	Q53e_dic_MV	0,000	-	-	-	-	-	0,122	0,000	Low relation, Cramer less than 0,2
	Q53f_dic_MV	0,000	-	-	-	-	-	0,136	0,000	Low relation, Cramer less than 0,2
	 Q55_dic_MV	0,000	-	-	-	-	-	0,107	0,000	Low relation, Cramer less than 0,2
	 Q71a_dic_MV	0,000	-	-	-	-	-	0,205	0,000	Moderate relation, Cramer less than 0,3
	Q71b_dic_MV	0,000	-	-	-	-	-	0,194	0,000	Low relation, Cramer less than 0,2
	Q71c_dic_MV	0,000	-	-	-	-	-	0,117	0,000	Low relation, Cramer less than 0,2
	 Q78a_dic_MV		-	-	0,000	-	-	0,056	0,000	Very low relation, Cramer almost null
	Q78b_dic_MV		-	-	0,000	-	-	0,067	0,000	Very low relation, Cramer almost null
	Q78c_dic_MV	0,000	-	-	-	-	-	0,039	0,000	Very low relation, Cramer almost null
	Q78d_dic_MV	0,000	-	-	-	-	-	0,083	0,000	Very low relation, Cramer almost null
	Q78e_dic_MV	0,000	-	-	-	-	-	0,029	0,000	Very low relation, Cramer almost null
	Q78f_dic_MV	0,000	-	-	-	-	-	0,069	0,000	Very low relation, Cramer almost null
	Q78g_dic_MV		-	-	0,000	-	-	0,037	0,000	Very low relation, Cramer almost null
	Q78h_dic_MV	0,000	-	-	-	-	-	0,098	0,000	Very low relation, Cramer almost null
	Q78i_dic_MV	0,000	-	-	-	-	-	0,074	0,000	Very low relation, Cramer almost null
	 Q37a_dic	0,000	-	-	-	-	-	0,057	0,000	Very low relation, Cramer almost null
	Q37b_dic	0,000	-	-	-	-	-	0,066	0,000	Very low relation, Cramer almost null
	Q37c_dic		0,918	-	-	-	-	-	-	Not associated, p_{value} exceeds 0,05 threshold
	Q37d_dic	0,000	-	-	-	-	-	0,135	0,000	Low relation, Cramer less than 0,2
	 Q38_dic_inv	0,000	-	-	-	-	-	0,081	0,000	Very low relation, Cramer almost null
	 Q39a_dic	0,000	-	-	-	-	-	0,090	0,000	Very low relation, Cramer almost null
	Q39b_dic	0,000	-	-	-	-	-	0,048	0,000	Very low relation, Cramer almost null
	Q39c_dic	0,000	-	-	-	-	-	0,091	0,000	Very low relation, Cramer almost null
Q39d_dic	0,000	-	-	-	-	-	0,092	0,000	Very low relation, Cramer almost null	
Q39e_dic		0,325	-	-	-	-	-	-	Not associated, p_{value} exceeds 0,05 threshold	

Tabla 4 (continuación)

Variable tested	Association with	Group	Statistics p value (2-sided)								Comments
			Pearson's χ^2		Likelihood Ratio		Fisher's Exact Test		Cramer's V		
			Sig	Non-sig.	Sig	Non-sig.	Sig	Non-sig.	Value	Sig	
Q64_aRect	Q65a_dic_MV	Carrer develop	0,000	-	-	-	-	-	0,190	0,000	Low relation, Cramer less than 0,2
		Q65b_dic_MV	-	-	-	-	0,000	-	0,094	0,000	Very low relation, Cramer almost null
		Q65c_dic_MV	0,000	-	-	-	-	-	0,158	0,000	Low relation, Cramer less than 0,2
		Q65d_dic_MV	0,000	-	-	-	-	-	0,121	0,000	Low relation, Cramer less than 0,2
Q64_bRect	Q65a_dic_MV	Carrer develop	0,000	-	-	-	-	-	0,091	0,000	Very low relation, Cramer almost null
		Q65b_dic_MV	-	-	-	-	0,000	-	0,074	0,000	Very low relation, Cramer almost null
		Q65c_dic_MV	0,000	-	-	-	-	-	0,073	0,000	Very low relation, Cramer almost null
		Q65d_dic_MV	0,000	-	-	-	-	-	0,077	0,000	Very low relation, Cramer almost null
Q64_cRect	Q65a_dic_MV	Carrer develop	0,000	-	-	-	-	-	0,045	0,000	Very low relation, Cramer almost null
		Q65b_dic_MV	-	-	-	-	0,086	-	-	0,085	Not associated, p value exceeds 0,05 threshold
		Q65d_dic_MV	-	0,208	-	-	-	-	-	-	Not associated, p value exceeds 0,05 threshold
Q42_dic1	Q50a_dic_MV	Control	0,000	-	-	-	-	-	0,031	0,000	Very low relation, Cramer almost null
		Q50b_dic_MV	0,000	-	-	-	-	-	0,073	0,000	Very low relation, Cramer almost null
		Q50c_dic_MV	0,000	-	-	-	-	-	0,027	0,000	Very low relation, Cramer almost null
		Q50d_dic_MV	0,000	-	-	-	-	-	0,093	0,000	Very low relation, Cramer almost null
		Q50e_dic_MV	0,000	-	-	-	-	-	0,152	0,000	Low relation, Cramer less than 0,2
	Q52_dic1	Control	0,000	-	-	-	-	-	0,086	0,000	Very low relation, Cramer almost null
		Q52_dic2	0,000	-	-	-	-	-	0,098	0,000	Very low relation, Cramer almost null
		Q52_dic3	-	-	-	-	0,000	-	0,031	0,000	Very low relation, Cramer almost null
	Q54a_dic_MV	Control	0,000	-	-	-	-	-	0,247	0,000	Moderate relation, Cramer less than 0,3
		Q54b_dic_MV	0,000	-	-	-	-	-	0,198	0,000	Low relation, Cramer less than 0,2
Q54c_dic_MV		0,000	-	-	-	-	-	0,160	0,000	Low relation, Cramer less than 0,2	
Q58_dic_MV		0,000	-	-	-	-	-	0,046	0,000	Very low relation, Cramer almost null	
Q50a_dic_MV		-	0,147	-	-	-	-	-	-	Not associated, p value exceeds 0,05 threshold	
Q42_dic2	Q50b_dic_MV	Control	0,000	-	-	-	-	-	0,044	0,000	Very low relation, Cramer almost null
		Q50c_dic_MV	-	0,944	-	-	-	-	-	-	Not associated, p value exceeds 0,05 threshold
		Q50d_dic_MV	-	0,821	-	-	-	-	-	-	Not associated, p value exceeds 0,05 threshold
		Q50e_dic_MV	0,000	-	-	-	-	-	0,035	0,000	Very low relation, Cramer almost null
		Q52_dic1	-	0,696	-	-	-	-	-	-	Not associated, p value exceeds 0,05 threshold
	Q52_dic2	Control	-	0,508	-	-	-	-	-	-	Not associated, p value exceeds 0,05 threshold
		Q52_dic3	-	-	-	-	-	0,566	-	-	Not associated, p value exceeds 0,05 threshold
	Q54a_dic_MV	Control	0,000	-	-	-	-	-	0,024	0,000	Very low relation, Cramer almost null
		Q54b_dic_MV	0,000	-	-	-	-	-	0,027	0,000	Very low relation, Cramer almost null
		Q54c_dic_MV	0,006	-	-	-	-	-	0,016	0,006	Very low relation, Cramer almost null
Q58_dic_MV		0,000	-	-	-	-	-	0,021	0,000	Very low relation, Cramer almost null	
Q50a_dic_MV		0,006	-	-	-	-	-	0,016	0,006	Very low relation, Cramer almost null	
Q42_dic3	Q50b_dic_MV	Control	0,000	-	-	-	-	-	0,048	0,000	Very low relation, Cramer almost null
		Q50c_dic_MV	0,000	-	-	-	-	-	0,029	0,000	Very low relation, Cramer almost null
		Q50d_dic_MV	0,000	-	-	-	-	-	0,083	0,000	Very low relation, Cramer almost null
		Q50e_dic_MV	0,000	-	-	-	-	-	0,107	0,000	Low relation, Cramer less than 0,2
		Q52_dic1	0,000	-	-	-	-	-	0,105	0,000	Low relation, Cramer less than 0,2
	Q52_dic2	Control	0,000	-	-	-	-	-	0,110	0,000	Low relation, Cramer less than 0,2
		Q52_dic3	-	-	-	-	0,001	-	0,020	0,001	Very low relation, Cramer almost null
	Q54a_dic_MV	Control	0,000	-	-	-	-	-	0,219	0,000	Moderate relation, Cramer less than 0,3
		Q54b_dic_MV	0,000	-	-	-	-	-	0,164	0,000	Low relation, Cramer less than 0,2
		Q54c_dic_MV	0,000	-	-	-	-	-	0,134	0,000	Low relation, Cramer less than 0,2
Q58_dic_MV	0,000	-	-	-	-	-	0,061	0,000	Very low relation, Cramer almost null		

Tabla 4 (continuación)

Variable tested	Association with	Group	Statistics p_{value} (2-sided)								Comments
			Pearson's χ^2		Likelihood Ratio		Fisher's Exact Test		Cramer's V		
			Sig	Non-sig.	Sig	Non-sig.	Sig	Non-sig.	Value	Sig	
Q42_dic4	Q50a_dic_MV	Control	0,000	-	-	-	-	-	0,051	0,000	Very low relation, Cramer almost null
	Q50b_dic_MV	Control	0,005	-	-	-	-	-	0,016	0,005	Very low relation, Cramer almost null
	Q50c_dic_MV	Control	-	0,263	-	-	-	-	-	-	Not associated, p_{value} exceeds 0,05 threshold
	Q50d_dic_MV	Control	0,000	-	-	-	-	-	0,054	0,000	Very low relation, Cramer almost null
	Q50e_dic_MV	Control	0,000	-	-	-	-	-	0,091	0,000	Very low relation, Cramer almost null
	Q52_dic1	Control	-	0,381	-	-	-	-	-	-	Not associated, p_{value} exceeds 0,05 threshold
	Q52_dic2	Control	-	0,129	-	-	-	-	-	-	Not associated, p_{value} exceeds 0,05 threshold
	Q52_dic3	Control	-	-	-	-	0,000	-	0,027	0,000	Very low relation, Cramer almost null
	Q54a_dic_MV	Control	0,000	-	-	-	-	-	0,110	0,000	Low relation, Cramer less than 0,2
	Q54b_dic_MV	Control	0,000	-	-	-	-	-	0,099	0,000	Very low relation, Cramer almost null
Q50a_dic_MV	Q54c_dic_MV	Control	0,000	-	-	-	-	-	0,086	0,000	Very low relation, Cramer almost null
	Q58_dic_MV	Control	0,000	-	-	-	-	-	0,038	0,000	Very low relation, Cramer almost null
	Q52_dic1	Control	0,000	-	-	-	-	-	0,139	0,000	Low relation, Cramer less than 0,2
	Q52_dic2	Control	0,000	-	-	-	-	-	0,146	0,000	Low relation, Cramer less than 0,2
	Q52_dic3	Control	-	-	-	-	0,000	-	0,027	0,000	Very low relation, Cramer almost null
	Q54a_dic_MV	Control	0,000	-	-	-	-	-	0,033	0,000	Very low relation, Cramer almost null
	Q54b_dic_MV	Control	0,000	-	-	-	-	-	0,035	0,000	Very low relation, Cramer almost null
	Q54c_dic_MV	Control	0,000	-	-	-	-	-	0,045	0,000	Very low relation, Cramer almost null
	Q58_dic_MV	Control	0,000	-	-	-	-	-	0,258	0,000	Moderate relation, Cramer less than 0,3
	Q50b_dic_MV	Q52_dic1	Control	0,000	-	-	-	-	-	0,127	0,000
Q50c_dic_MV	Q52_dic2	Control	0,000	-	-	-	-	-	0,127	0,000	Low relation, Cramer less than 0,2
	Q52_dic3	Control	-	-	-	-	0,027	-	0,013	0,027	Very low relation, Cramer almost null
	Q54a_dic_MV	Control	0,000	-	-	-	-	-	0,068	0,000	Very low relation, Cramer almost null
	Q54b_dic_MV	Control	0,000	-	-	-	-	-	0,080	0,000	Very low relation, Cramer almost null
	Q54c_dic_MV	Control	0,000	-	-	-	-	-	0,032	0,000	Very low relation, Cramer almost null
	Q58_dic_MV	Control	0,000	-	-	-	-	-	0,085	0,000	Very low relation, Cramer almost null
	Q52_dic1	Control	0,000	-	-	-	-	-	0,102	0,000	Low relation, Cramer less than 0,2
	Q52_dic2	Control	0,000	-	-	-	-	-	0,109	0,000	Low relation, Cramer less than 0,2
	Q52_dic3	Control	-	-	-	-	0,000	-	0,023	0,000	Very low relation, Cramer almost null
	Q54a_dic_MV	Control	0,000	-	-	-	-	-	0,021	0,000	Very low relation, Cramer almost null
Q50d_dic_MV	Q54b_dic_MV	Control	0,017	-	-	-	-	-	0,014	0,017	Low relation, Cramer less than 0,2
	Q54c_dic_MV	Control	0,000	-	-	-	-	-	0,034	0,000	Very low relation, Cramer almost null
	Q58_dic_MV	Control	0,000	-	-	-	-	-	0,102	0,000	Low relation, Cramer less than 0,2
	Q52_dic1	Control	0,030	-	-	-	-	-	0,012	0,030	Very low relation, Cramer almost null
	Q52_dic2	Control	0,000	-	-	-	-	-	0,021	0,000	Very low relation, Cramer almost null
	Q52_dic3	Control	-	-	-	-	0,001	-	0,019	0,001	Very low relation, Cramer almost null
	Q54a_dic_MV	Control	0,000	-	-	-	-	-	0,149	0,000	Low relation, Cramer less than 0,2
	Q54b_dic_MV	Control	0,000	-	-	-	-	-	0,136	0,000	Low relation, Cramer less than 0,2
	Q54c_dic_MV	Control	0,000	-	-	-	-	-	0,111	0,000	Low relation, Cramer less than 0,2
	Q58_dic_MV	Control	0,000	-	-	-	-	-	0,047	0,000	Very low relation, Cramer almost null
Q50e_dic_MV	Q52_dic1	Control	0,000	-	-	-	-	-	0,067	0,000	Very low relation, Cramer almost null
	Q52_dic2	Control	0,000	-	-	-	-	-	0,061	0,000	Very low relation, Cramer almost null
	Q52_dic3	Control	-	-	-	-	-	0,401	-	-	Not associated, p_{value} exceeds 0,05 threshold
	Q54a_dic_MV	Control	0,000	-	-	-	-	-	0,123	0,000	Low relation, Cramer less than 0,2
	Q54b_dic_MV	Control	0,000	-	-	-	-	-	0,111	0,000	Low relation, Cramer less than 0,2
	Q54c_dic_MV	Control	0,000	-	-	-	-	-	0,104	0,000	Low relation, Cramer less than 0,2
	Q58_dic_MV	Control	0,000	-	-	-	-	-	0,057	0,000	Very low relation, Cramer almost null
	Q54a_dic_MV	Control	0,000	-	-	-	-	-	0,081	0,000	Very low relation, Cramer almost null
	Q54b_dic_MV	Control	0,000	-	-	-	-	-	0,066	0,000	Very low relation, Cramer almost null
	Q54c_dic_MV	Control	-	0,087	-	-	-	-	-	-	Not associated, p_{value} exceeds 0,05 threshold
Q58_dic_MV	Control	0,000	-	-	-	-	-	0,102	0,000	Low relation, Cramer less than 0,2	

Tabla 4 (continuación)

Variable tested	Association with	Group	Statistics p_{value} (2-sided)								Comments	
			Pearson's χ^2		Likelihood Ratio		Fisher's Exact Test		Cramer's V			
			Sig	Non-sig.	Sig	Non-sig.	Sig	Non-sig.	Value	Sig		
Q52_dic2	Q54a_dic_MV	Control	0,000	-	-	-	-	-	-	0,091	0,000	Very low relation, Cramer almost null
	Q54b_dic_MV	Control	0,000	-	-	-	-	-	-	0,076	0,000	Very low relation, Cramer almost null
	Q54c_dic_MV	Control	0,000	-	-	-	-	-	-	0,020	0,000	Very low relation, Cramer almost null
Q52_dic3	Q58_dic_MV	Control	0,000	-	-	-	-	-	-	0,117	0,000	Low relation, Cramer less than 0,2
	Q54a_dic_MV	Control	0,000	-	-	-	-	-	-	0,028	0,000	Very low relation, Cramer almost null
	Q54b_dic_MV	Control	0,000	-	-	-	-	-	-	0,027	0,000	Very low relation, Cramer almost null
Q54a_dic_MV	Q54c_dic_MV	Control	0,000	-	-	-	-	-	-	0,022	0,000	Very low relation, Cramer almost null
	Q58_dic_MV	Control	0,000	-	-	-	-	-	-	0,040	0,000	Very low relation, Cramer almost null
	Q58_dic_MV	Control	0,000	-	-	-	-	-	-	0,075	0,000	Very low relation, Cramer almost null
Q54b_dic_MV	Q58_dic_MV	Control	0,000	-	-	-	-	-	0,076	0,000	Very low relation, Cramer almost null	
Q54c_dic_MV	Q58_dic_MV	Control	0,000	-	-	-	-	-	0,059	0,000	Very low relation, Cramer almost null	
Q31_dic_MV	Q34_dic_MV	Environment & equipment	0,000	-	-	-	-	-	-	0,072	0,000	Very low relation, Cramer almost null
	Q72a_dic_MV	Environment & equipment	-	-	-	-	0,000	-	-	0,026	0,000	Very low relation, Cramer almost null
	Q72b_dic_MV	Environment & equipment	-	-	-	-	0,000	-	-	0,033	0,000	Very low relation, Cramer almost null
	Q72c_dic_MV	Environment & equipment	-	-	-	-	0,000	-	-	0,032	0,000	Very low relation, Cramer almost null
	Q72d_dic_MV	Environment & equipment	-	-	-	-	-	0,328	-	-	-	Not associated, p_{value} exceeds 0,05 threshold
	Q72e_dic_MV	Environment & equipment	-	-	-	-	0,000	-	-	0,021	0,000	Very low relation, Cramer almost null
	Q72f_dic_MV	Environment & equipment	-	-	-	-	-	0,093	-	-	-	Not associated, p_{value} exceeds 0,05 threshold
	Q72g_dic_MV	Environment & equipment	-	-	-	-	-	0,565	-	-	-	Not associated, p_{value} exceeds 0,05 threshold
	Q73_dic_MV	Environment & equipment	0,000	-	-	-	-	-	-	0,267	0,000	Moderate relation, Cramer less than 0,3
	Q80a_dic_MV	Environment & equipment	0,000	-	-	-	-	-	-	0,053	0,000	Very low relation, Cramer almost null
	Q80b_dic_MV	Environment & equipment	-	-	-	-	-	-	0,088	-	-	Not associated, p_{value} exceeds 0,05 threshold
	Q80c_dic_MV	Environment & equipment	-	-	-	-	0,000	-	-	0,045	0,000	Very low relation, Cramer almost null
	Q80d_dic_MV	Environment & equipment	-	-	-	-	0,000	-	-	0,041	0,000	Very low relation, Cramer almost null
Q34_dic_MV	Q81a_dic_MV	Environment & equipment	-	-	-	-	0,000	-	-	0,073	0,000	Very low relation, Cramer almost null
	Q81b_dic_MV	Environment & equipment	-	-	-	-	-	0,144	-	-	-	Not associated, p_{value} exceeds 0,05 threshold
	Q81c_dic_MV	Environment & equipment	0,000	-	-	-	-	-	-	0,044	0,000	Very low relation, Cramer almost null
	Q72a_dic_MV	Environment & equipment	-	-	-	-	-	0,058	-	-	-	Not associated, p_{value} exceeds 0,05 threshold
	Q72b_dic_MV	Environment & equipment	-	-	-	-	-	0,640	-	-	-	Not associated, p_{value} exceeds 0,05 threshold
	Q72c_dic_MV	Environment & equipment	-	-	-	-	-	0,964	-	-	-	Not associated, p_{value} exceeds 0,05 threshold
	Q72d_dic_MV	Environment & equipment	-	-	-	-	0,024	-	-	0,013	0,023	Very low relation, Cramer almost null
Q72e_dic_MV	Environment & equipment	-	-	-	-	-	0,836	-	-	-	Not associated, p_{value} exceeds 0,05 threshold	
Q72f_dic_MV	Environment & equipment	-	-	-	-	-	0,943	-	-	-	Not associated, p_{value} exceeds 0,05 threshold	
Q72g_dic_MV	Environment & equipment	-	-	-	-	-	0,454	-	-	-	Not associated, p_{value} exceeds 0,05 threshold	
Q72a_dic_MV	Q73_dic_MV	Environment & equipment	0,000	-	-	-	-	-	-	0,065	0,000	Very low relation, Cramer almost null
	Q80a_dic_MV	Environment & equipment	0,000	-	-	-	-	-	-	0,052	0,000	Very low relation, Cramer almost null
	Q80b_dic_MV	Environment & equipment	-	-	-	-	0,027	-	-	0,013	0,024	Very low relation, Cramer almost null
	Q80c_dic_MV	Environment & equipment	-	-	-	-	0,000	-	-	0,060	0,000	Very low relation, Cramer almost null
	Q80d_dic_MV	Environment & equipment	-	-	-	-	0,001	-	-	0,020	0,001	Very low relation, Cramer almost null
	Q81a_dic_MV	Environment & equipment	-	-	-	-	0,000	-	-	0,060	0,000	Very low relation, Cramer almost null
	Q81b_dic_MV	Environment & equipment	-	-	-	-	-	0,144	-	-	-	Not associated, p_{value} exceeds 0,05 threshold
Q81c_dic_MV	Environment & equipment	-	-	-	-	0,000	-	-	0,025	0,000	Very low relation, Cramer almost null	
Q72a_dic_MV	Q73_dic_MV	Environment & equipment	0,000	-	-	-	-	-	-	0,086	0,000	Very low relation, Cramer almost null
	Q80a_dic_MV	Environment & equipment	0,000	-	-	-	-	-	-	0,143	0,000	Low relation, Cramer less than 0,2
	Q80b_dic_MV	Environment & equipment	-	-	-	-	0,000	-	-	0,074	0,000	Very low relation, Cramer almost null
	Q80c_dic_MV	Environment & equipment	-	-	-	-	0,000	-	-	0,123	0,000	Low relation, Cramer less than 0,2
	Q80d_dic_MV	Environment & equipment	-	-	-	-	0,000	-	-	0,168	0,000	Low relation, Cramer less than 0,2
	Q81a_dic_MV	Environment & equipment	-	-	-	-	0,000	-	-	0,059	0,000	Very low relation, Cramer almost null
	Q81b_dic_MV	Environment & equipment	-	-	-	-	0,000	-	-	0,064	0,000	Very low relation, Cramer almost null
Q81c_dic_MV	Environment & equipment	-	-	-	-	0,000	-	-	0,145	0,000	Low relation, Cramer less than 0,2	

Tabla 4 (continuación)

Variable tested	Association with	Group	Statistics p_{value} (2-sided)								Comments
			Pearson's χ^2		Likelihood Ratio		Fisher's Exact Test		Cramer's V		
			Sig	Non-sig.	Sig	Non-sig.	Sig	Non-sig.	Value	Sig	
Q72b_dic_MV	Q73_dic_MV	Environment & equipment	0,000	-	-	-	-	-	0,062	0,000	Very low relation, Cramer almost null
	Q80a_dic_MV	Environment & equipment	0,000	-	-	-	-	-	0,110	0,000	Low relation, Cramer less than 0,2
	Q80b_dic_MV	Environment & equipment	-	-	-	-	0,000	-	0,059	0,000	Very low relation, Cramer almost null
	Q80c_dic_MV	Environment & equipment	-	-	-	-	0,000	-	0,089	0,000	Very low relation, Cramer almost null
	Q80d_dic_MV	Environment & equipment	-	-	-	-	0,000	-	0,126	0,000	Low relation, Cramer less than 0,2
	Q81a_dic_MV	Environment & equipment	-	-	-	-	0,000	-	0,052	0,000	Very low relation, Cramer almost null
	Q81b_dic_MV	Environment & equipment	-	-	-	-	0,000	-	0,050	0,000	Very low relation, Cramer almost null
Q72c_dic_MV	Q81c_dic_MV	Environment & equipment	-	-	-	-	0,000	-	0,139	0,000	Low relation, Cramer less than 0,2
	Q73_dic_MV	Environment & equipment	0,000	-	-	-	-	-	0,067	0,000	Very low relation, Cramer almost null
	Q80a_dic_MV	Environment & equipment	0,000	-	-	-	-	-	0,107	0,000	Low relation, Cramer less than 0,2
	Q80b_dic_MV	Environment & equipment	-	-	-	-	0,000	-	0,060	0,000	Very low relation, Cramer almost null
	Q80c_dic_MV	Environment & equipment	-	-	-	-	0,000	-	0,086	0,000	Very low relation, Cramer almost null
	Q80d_dic_MV	Environment & equipment	-	-	-	-	0,000	-	0,133	0,000	Low relation, Cramer less than 0,2
	Q81a_dic_MV	Environment & equipment	-	-	-	-	0,000	-	0,054	0,000	Very low relation, Cramer almost null
Q72d_dic_MV	Q81b_dic_MV	Environment & equipment	-	-	-	-	0,000	-	0,051	0,000	Very low relation, Cramer almost null
	Q81c_dic_MV	Environment & equipment	-	-	-	-	0,000	-	0,142	0,000	Low relation, Cramer less than 0,2
	Q73_dic_MV	Environment & equipment	0,000	-	-	-	-	-	0,052	0,000	Very low relation, Cramer almost null
	Q80a_dic_MV	Environment & equipment	0,000	-	-	-	-	-	0,119	0,000	Low relation, Cramer less than 0,2
	Q80b_dic_MV	Environment & equipment	-	-	-	-	0,000	-	0,131	0,000	Low relation, Cramer less than 0,2
	Q80c_dic_MV	Environment & equipment	-	-	-	-	0,000	-	0,113	0,000	Low relation, Cramer less than 0,2
	Q80d_dic_MV	Environment & equipment	-	-	-	-	0,000	-	0,146	0,000	Low relation, Cramer less than 0,2
Q72e_dic_MV	Q81a_dic_MV	Environment & equipment	-	-	-	-	0,000	-	0,067	0,000	Very low relation, Cramer almost null
	Q81b_dic_MV	Environment & equipment	-	-	-	-	0,000	-	0,114	0,000	Low relation, Cramer less than 0,2
	Q81c_dic_MV	Environment & equipment	-	-	-	-	0,000	-	0,150	0,000	Low relation, Cramer less than 0,2
	Q73_dic_MV	Environment & equipment	0,000	-	-	-	-	-	0,057	0,000	Very low relation, Cramer almost null
	Q80a_dic_MV	Environment & equipment	0,000	-	-	-	-	-	0,080	0,000	Very low relation, Cramer almost null
	Q80b_dic_MV	Environment & equipment	-	-	-	-	0,000	-	0,057	0,000	Very low relation, Cramer almost null
	Q80c_dic_MV	Environment & equipment	-	-	-	-	0,000	-	0,070	0,000	Very low relation, Cramer almost null
Q72f_dic_MV	Q80d_dic_MV	Environment & equipment	-	-	-	-	0,000	-	0,090	0,000	Very low relation, Cramer almost null
	Q81a_dic_MV	Environment & equipment	-	-	-	-	0,000	-	0,049	0,000	Very low relation, Cramer almost null
	Q81b_dic_MV	Environment & equipment	-	-	-	-	0,000	-	0,052	0,000	Very low relation, Cramer almost null
	Q81c_dic_MV	Environment & equipment	-	-	-	-	0,000	-	0,102	0,000	Low relation, Cramer less than 0,2
	Q73_dic_MV	Environment & equipment	0,000	-	-	-	-	-	0,049	0,000	Very low relation, Cramer almost null
	Q80a_dic_MV	Environment & equipment	0,000	-	-	-	-	-	0,062	0,000	Very low relation, Cramer almost null
	Q80b_dic_MV	Environment & equipment	-	-	-	-	0,000	-	0,032	0,000	Very low relation, Cramer almost null
Q72g_dic_MV	Q80c_dic_MV	Environment & equipment	-	-	-	-	0,000	-	0,058	0,000	Very low relation, Cramer almost null
	Q80d_dic_MV	Environment & equipment	-	-	-	-	0,000	-	0,078	0,000	Very low relation, Cramer almost null
	Q81a_dic_MV	Environment & equipment	-	-	-	-	0,000	-	0,051	0,000	Very low relation, Cramer almost null
	Q81b_dic_MV	Environment & equipment	-	-	-	-	0,000	-	0,033	0,000	Very low relation, Cramer almost null
	Q81c_dic_MV	Environment & equipment	-	-	-	-	0,000	-	0,082	0,000	Very low relation, Cramer almost null
	Q73_dic_MV	Environment & equipment	0,000	-	-	-	-	-	0,023	0,000	Very low relation, Cramer almost null
	Q80a_dic_MV	Environment & equipment	0,000	-	-	-	-	-	0,055	0,000	Very low relation, Cramer almost null
Q73_dic_MV	Q80b_dic_MV	Environment & equipment	-	-	-	-	0,000	-	0,063	0,000	Very low relation, Cramer almost null
	Q80c_dic_MV	Environment & equipment	-	-	-	-	0,000	-	0,071	0,000	Very low relation, Cramer almost null
	Q80d_dic_MV	Environment & equipment	-	-	-	-	0,000	-	0,076	0,000	Very low relation, Cramer almost null
	Q81a_dic_MV	Environment & equipment	-	-	-	-	0,000	-	0,057	0,000	Very low relation, Cramer almost null
	Q81b_dic_MV	Environment & equipment	-	-	-	-	0,000	-	0,084	0,000	Very low relation, Cramer almost null
	Q81c_dic_MV	Environment & equipment	-	-	-	-	0,000	-	0,080	0,000	Very low relation, Cramer almost null
	Q80a_dic_MV	Environment & equipment	0,000	-	-	-	-	-	0,178	0,000	Low relation, Cramer less than 0,2
Q73_dic_MV	Q80b_dic_MV	Environment & equipment	-	-	-	-	0,000	-	0,057	0,000	Very low relation, Cramer almost null
	Q80c_dic_MV	Environment & equipment	-	-	-	-	0,000	-	0,169	0,000	Low relation, Cramer less than 0,2
	Q80d_dic_MV	Environment & equipment	-	-	-	-	0,000	-	0,180	0,000	Low relation, Cramer less than 0,2
	Q81a_dic_MV	Environment & equipment	-	-	-	-	0,000	-	0,124	0,000	Low relation, Cramer less than 0,2
	Q81b_dic_MV	Environment & equipment	-	-	-	-	0,000	-	0,048	0,000	Very low relation, Cramer almost null
	Q81c_dic_MV	Environment & equipment	-	-	-	-	0,000	-	0,168	0,000	Low relation, Cramer less than 0,2

Tabla 4 (continuación)

Variable tested	Association with	Group	Statistics p value (2-sided)								Comments
			Pearson's χ^2		Likelihood Ratio		Fisher's Exact Test		Cramer's V		
			Sig	Non-sig.	Sig	Non-sig.	Sig	Non-sig.	Value	Sig	
Q80a_dic_MV	Q81a_dic_MV	Environment & equipment	-	-	-	-	0,000	-	0,279	0,000	Moderate relation, Cramer less than 0,3
	Q81b_dic_MV	Environment & equipment	-	-	-	-	0,000	-	0,133	0,000	Low relation, Cramer less than 0,2
	Q81c_dic_MV	Environment & equipment	-	-	-	-	0,000	-	0,320	0,000	Strong relation, Cramer above 0,3
Q80b_dic_MV	Q81a_dic_MV	Environment & equipment	-	-	-	-	0,000	-	0,170	0,000	Moderate relation, Cramer less than 0,3
	Q81b_dic_MV	Environment & equipment	-	-	-	-	0,000	-	0,514	0,000	Strong relation, Cramer above 0,3
	Q81c_dic_MV	Environment & equipment	-	-	-	-	0,000	-	0,146	0,000	Low relation, Cramer less than 0,2
Q80c_dic_MV	Q81a_dic_MV	Environment & equipment	-	-	-	-	0,000	-	0,367	0,000	Strong relation, Cramer above 0,3
	Q81b_dic_MV	Environment & equipment	-	-	-	-	0,000	-	0,147	0,000	Low relation, Cramer less than 0,2
	Q81c_dic_MV	Environment & equipment	-	-	-	-	0,000	-	0,349	0,000	Strong relation, Cramer above 0,3
Q80d_dic_MV	Q81a_dic_MV	Environment & equipment	-	-	-	-	0,000	-	0,211	0,000	Moderate relation, Cramer less than 0,3
	Q81b_dic_MV	Environment & equipment	-	-	-	-	0,000	-	0,161	0,000	Low relation, Cramer less than 0,2
	Q81c_dic_MV	Environment & equipment	-	-	-	-	0,000	-	0,417	0,000	Strong relation, Cramer above 0,3
Q48a_dic_MV	Q53a_dic_MV	Job content	0,000	-	-	-	-	-	0,098	0,000	Very low relation, Cramer almost null
	Q53b_dic_MV	Job content	0,000	-	-	-	-	-	0,028	0,000	Very low relation, Cramer almost null
	Q53c_dic_MV	Job content	0,003	-	-	-	-	-	0,017	0,003	Very low relation, Cramer almost null
	Q53d_dic_MV	Job content	0,000	-	-	-	-	-	0,232	0,000	Moderate relation, Cramer less than 0,3
	Q53e_dic_MV	Job content	0,000	-	-	-	-	-	0,032	0,000	Very low relation, Cramer almost null
	Q53f_dic_MV	Job content	0,000	-	-	-	-	-	0,023	0,000	Very low relation, Cramer almost null
	Q55_dic_MV	Job content	0,000	-	-	-	-	-	0,067	0,000	Very low relation, Cramer almost null
Q48b_dic_MV	Q53a_dic_MV	Job content	0,000	-	-	-	-	-	0,111	0,000	Low relation, Cramer less than 0,2
	Q53b_dic_MV	Job content	0,000	-	-	-	-	-	0,025	0,000	Very low relation, Cramer almost null
	Q53c_dic_MV	Job content		0,992	-	-	-	-	-	-	Not associated, p value exceeds 0,05 threshold
	Q53d_dic_MV	Job content	0,000	-	-	-	-	-	0,249	0,000	Moderate relation, Cramer less than 0,3
	Q53e_dic_MV	Job content		0,784	-	-	-	-	-	-	Not associated, p value exceeds 0,05 threshold
	Q53f_dic_MV	Job content	0,006	-	-	-	-	-	0,016	0,006	Very low relation, Cramer almost null
	Q55_dic_MV	Job content	0,000	-	-	-	-	-	0,102	0,000	Low relation, Cramer less than 0,2
Q53a_dic_MV	Q55_dic_MV	Job content	0,000	-	-	-	-	-	0,088	0,000	Very low relation, Cramer almost null
Q53b_dic_MV	Q55_dic_MV	Job content	0,000	-	-	-	-	-	0,071	0,000	Very low relation, Cramer almost null
Q53c_dic_MV	Q55_dic_MV	Job content	0,000	-	-	-	-	-	0,077	0,000	Very low relation, Cramer almost null
Q53d_dic_MV	Q55_dic_MV	Job content	0,003	-	-	-	-	-	0,017	0,003	Very low relation, Cramer almost null
Q53e_dic_MV	Q55_dic_MV	Job content	0,000	-	-	-	-	-	0,117	0,000	Low relation, Cramer less than 0,2
Q53f_dic_MV	Q55_dic_MV	Job content	0,000	-	-	-	-	-	0,151	0,000	Low relation, Cramer less than 0,2

Tabla 5. Análisis entre variables nominales y ordinales















Variable tested	Association with	Non-parametric inferential Statistics P_{value} (2-sided)						Comments
		Mann-Whitney U Test			Standardized Test statistics			
		Sig.	Non-sig.	H0 Hypothesis	Reject	Accept	Value	
 Q20_dic	 Q22_Rect	0,056	0,056	Yes	Yes	1,910	0,056	The distribution of Q22_Rect is the same across categories of Q20_dic, therefore H0 is accepted
 Q24_cat	 Q24_cat	0,000	0,000	Yes	Yes	4,489	0,000	People whose workplace didn't suffered any reorganization (Q20, value 0), are more likely to work between 22 till 45 hours/week (Q24, cat.2)
 Q26_cat	 Q26_cat	0,000	0,000	Yes	Yes	-10,789	0,000	People whose workplace didn't suffered any reorganization (Q20, value 0), are much more likely to work 5 days/week (Q26, cat.2)
 Q36_cat	 Q36_cat	0,000	0,000	Yes	Yes	12,005	0,000	People whose workplace didn't suffered any reorganization (Q20, value 0), are much more likely to spend no more than 30 minutes/day in displacements to work and back home (Q36, cat.1)
 Q64_TOTAL	 Q64_TOTAL	0,000	0,000	Yes	Yes	-4,857	0,000	There is a relationship between the good adjustment of the aptitudes of the worker to their tasks (Q64, value 2) and the absence of reorganization of its workplace in the last three years (Q20, value 0)
 Q65_TOTAL	 Q65_TOTAL	0,000	0,000	Yes	Yes	31,057	0,000	The absence of any substantial reorganization in the company during the last three years (Q20, value 0) is positively related to the main trend regarding the lack of training attended by the worker in the last twelve months (Q65, value 0)
 Q42_TOTAL	 Q42_TOTAL	0,000	0,000	Yes	Yes	20,036	0,000	There is a strong relationship between the work hours set by the company, with no possibility of change (Q42, value 1) and the absence of any substantial reorganization of the respondent's workplace during the last three years (Q20, value 0)

Tabla 5 (continuación)











Variable tested	Association with	Non-parametric inferential Statistics p_{value} (2-sided)					Comments
		Mann-Whitney U Test		Standardized Test statistics			
		Sig.	Non-sig. Test	H0 Hypothesis	Accept	Value	
 (idem)		0,000		Yes	16,099	0,000	There is na above-average relationship between the amount of 2 to 3 factors of the listed on which the workplace depends (Q50, values 3 and 2) and the absence of any substantial reorganization of the respondent's workplace during the last three years (Q20, value 0)
	Q52_TOTAL	0,000		Yes	24,578	0,000	There is a strong relationship between the the absence of any substantial reorganization of the respondent's workplace during the last three years (Q20, value 0), and the absence of consequences resulting from work interruptions (Q52, value 2)
	Q54_TOTAL	0,000		Yes	9,195	0,000	There is a relationship, supposedly negative, between the ability of the worker in choosing or changing at least the work pace and work methods (Q54 value 6), and the absence of reorganization on its workplace in the last three years (Q20, value 0)
	Q72_TOTAL	0,000		Yes	15,094	0,000	There is a strong relationship between the absence of discriminations suffered (Q72 value 0) and the absence of reorganization of the workplace in the last three years (Q20, value 0)
	Q80_TOTAL	0,000		Yes	21,004	0,000	There is a strong relationship between the absence of offences or threats suffered at work (Q80 value 0) and the absence of reorganization os its workplace in the last three years (Q20, value 0)
	Q81_TOTAL	0,000		Yes	19,861	0,000	There is a relationship between the absence of violence or harassments suffered at work during las 12 months (Q81 value 0) and the absence of reorganization os its workplace in the last three years (Q20, value 0)
	Q23_cat	0,000		Yes	19,529	0,000	People whose workplace didn't suffered any reorganization (Q20, value 0), are much more likely to have no one under supervision (Q23, value 1)
	Q48_TOTAL	0,011		Yes	2,559	0,011	There is a relationship between the absence of breve or repetitive tasks performed or those last more than 10 minutes to perform (Q48 value 0), and the absence of reorganization os its workplace in the last three years (Q20, value 0)
	Q71_TOTAL	0,000		Yes	33,566	0,000	Despite strong, it is not quite clear the relationship between the existence and type of workers' conditions defense structure, which tends to be primordially absent or, at a lesser level, to exist according to all forms listed (Q71 values 0 and 7), and the absence of reorganization os its workplace in the last three years (Q20, value 0)
	Q78_TOTAL	0,000		Yes	18,697	0,000	There is a relationship between the tendency for absence of any health problems due to work (Q78 value 0), and the absence of reorganization os its workplace in the last three years (Q20, value 0)

Tabla 6. Análisis entre variables ordinales







Variable tested	Association with														
	Non-parametric inferential Statistics p value (2-sided)														
	Wilcoxon Signed-Rank Test	H0 Hypothesis	Standardized Test statistics	MEAN	Z Test	Sig	Non-sig.	Reject	Accept	Value	Sig. (2-sided)	Var. 1	Var. 2	Value	Comments
Variable 1															
 Q22_Rect	Q24_cat	Yes	54,183	0,000	1,70	2,04	-54,183								When at the workplace there is a groing trend for decrease of the majority of men, approaching the gender balance (Q22, value 1 to 2), there is a positive relationship with the amount of hours worked/week, which tends to be between 22 till 45 (Q24, value 2)
 Q26_cat		Yes	53,564	0,000	1,70	2,04	-53,564								When at the workplace there is a groing trend for decrease of the majority of men, approaching the gender balance (Q22, value 1 to 2), there is a positive relationship with the amount of days worked/week tends to be 5 (Q26, value 2)
 Q36_cat		Yes	-13,216	0,000	1,70	1,62	-13,216								When at the workplace there is a groing trend for decrease of the majority of men, approaching the gender balance (Q22, value 1 to 2), there is no clarity in the negative relationship with the amount of time/day spent to go to work and back home, which tends to be equal or less than 30 minutes (Q36, value 2 to 1)
 Q64_TOTAL		Yes	65,806	0,000	1,70	2,14	-65,806								When at the workplace there is a groing trend for decrease of the majority of men, approaching the gender balance (Q22, value 1 to 2), there is a positive relationship with the trend for groing the adjustment of the aptitudes of the worker to the taks he must accomplish (Q64, value 2)
 Q65_TOTAL		Yes	-83,652	0,000	1,70	0,96	-83,652								When at the workplace there is a groing trend for decrease of the majority of men, approaching the gender balance (Q22, value 1 to 2), there is a negative relationship with the existence of one single kind of formation during the last 12 months (Q65, value 1)
 Q42_TOTAL		Yes	-17,642	0,000	1,70	1,59	-17,642								When at the workplace there is a groing trend for decrease of the majority of men, approaching the gender balance (Q22, value 1 to 2), there is no clarity on the negative relationship with the working time schedule of the respondent, tending from some degree of choice to become fixed by company, with no changes (Q42, Value 2 to 1)
 Q50_TOTAL		Yes	39,420	0,000	1,70	2,08	-39,420								When at the workplace there is a groing trend for decrease of the majority of men, approaching the gender balance (Q22, value 1 to 2), there is a positive relationship with the workplace, which tends to depend on, at least, two conditioning aspects (Q50, value 2)
 Q52_TOTAL		Yes	78,449	0,000	1,70	2,23	-78,449								When at the workplace there is a groing trend for decrease of the majority of men, approaching the gender balance (Q22, value 1 to 2), there is a positive relationship with task interruptions having no consequences in the workplace (Q52, value 2)

Tabla 6 (continuación)









Variable tested	Association with	Non-parametric inferential Statistics p_{value} (2-sided)																			
		Wilcoxon Signed-Rank Test		H0 Hypothesis		Standardized Test statistics		MEAN		Z Test											
		Sig	Non-sig.	Reject	Accept	Value	Sig. (2-sided)	Var. 1	Var. 2	Value	Z Test										
Variable 1 (idem)	Variable 2																				
 Q54_TOTAL		0,000		Yes		124,841	0,000	1,70	4,68	-124,841											When at the workplace the majority of men tends to decrease, approaching the gender balance (Q22, value 1 to 2), there is a positive relationship with the worker's ability to choose up to approximately two types of changes in their tasks, sequence of tasks and workplace (Q54, value 4 to 5)
 Q72_TOTAL		0,000		Yes		-140,568	0,000	1,70	0,11	-140,568											When at the workplace there is a growing trend for decrease of the majority of men, approaching the gender balance (Q22, value 1 to 2), there is a clear negative relationship with the absence of any kind of discrimination during the last 12 months (Q72, value 0)
 Q80_TOTAL		0,000		Yes		-134,122	0,000	1,70	0,24	-134,122											When at the workplace there is a growing trend for decrease of the majority of men, approaching the gender balance (Q22, value 1 to 2), there is a clear negative relationship with absence of any kind of offenses, harassment, threats of humiliating behaviors during last month (Q80, value 0)
 Q81_TOTAL		0,000		Yes		-124,876	0,000	1,70	0,24	-124,876											When at the workplace there is a growing trend for decrease of the majority of men, approaching the gender balance (Q22, value 1 to 2), there is a clear negative relationship with the absence of any kind of violence, sexual harassment or intimidation during the last 12 months (Q81, value 0)
 Q23_cat		0,000		Yes		-75,212	0,000	1,70	1,19	-75,212											When at the workplace there is a growing trend for decrease of the majority of men, approaching the gender balance (Q22, value 1 to 2), there is a negative relationship with the amount of colleagues under supervision by the respondent, which tends to be close to 0 (Q23, value 1)
 Q48_TOTAL		0,000		Yes		-68,983	0,000	1,70	1,04	-68,983											When at the workplace there is a growing trend for decrease of the majority of men, approaching the gender balance (Q22, value 1 to 2), there is a clear negative relationship with the tasks accomplished by the respondent, which tend to entail brief and successive repetitions lasting about one minute or less (N48 value 1)
 Q71_TOTAL		0,000		Yes		99,625	0,000	1,70	3,71	-99,625											When at the workplace there is a growing trend for decrease of the majority of men, approaching the gender balance (Q22, value 1 to 2), there is a positive relationship with the existing of types of representation of the interests of respondent's company workers, union and delegate to regular meetings (Q71, value 3 to 4)
 Q78_TOTAL		0,000		Yes		43,861	0,000	1,70	2,32	-43,861											When at the workplace the majority of men tends to decrease, approaching the gender balance (Q22, value 1 to 2), there is a positive relationship with a trend to point out at least two health problems in the last 12 months (Q78, value 2)

Tabla 6 (continuación)

Variable tested	Association with	Non-parametric inferential Statistics p_{value} (2-sided)						Z Test	Comments		
		Wilcoxon Signed-Rank Test	HO Hypothesis		Standardized Test statistics		MEAN				
		Sig	Non-sig.	Reject	Accept	Value	Sig. (2-sided)	Var. 1	Var. 2	Value	
Variable 1 Q24_cat	Variable 2 Q26_cat	0,583		Yes	Yes	-0,549	0,583	-	-	-	The median of the differences between variables equals 0, being accepted the HO
	Q36_cat	0,000		Yes		-77,063	0,000	2,04	1,62	-77,063	When the majority of time worked/week is between 22 and 45 hours (Q24, value 2), the time spent to go work and back home tends to be around or a bit above 30 minutes/day (Q36, value between 1 and 2)
	Q64_TOTAL	0,000		Yes		21,681	0,000	2,04	2,14	-21,681	When the majority of time worked/week is between 22 and 45 hours (Q24, value 2), there is a matching relationship with the aptitudes of the worker, which tend to be adjusted to the tasks he must accomplish (Q64, value 2)
	Q65_TOTAL	0,000		Yes		-117,618	0,000	2,04	0,96	-117,618	When the majority of time worked/week is between 22 and 45 hours (Q24, value 2), there is a strong negative relationship with the amount of kinds of formation done during the last 12 months, which tends to be one (Q65, value 1)
	Q42_TOTAL	0,000		Yes		-68,713	0,000	2,04	1,59	-68,713	When the majority of time worked/week is between 22 and 45 hours (Q24, value 2), there is a negative relationship with the way the work schedule is settled, tending to become from several possibilities offered to that one imposed by the company (Q42, value 2 to 1)
	Q50_TOTAL	0,000		Yes		3,966	0,000	2,04	2,08	-3,966	When the majority of time worked/week is between 22 and 45 hours (Q24, value 2), there is some positive relationship with the factors on which the pace of work depends, which will increase slightly (Q50, value 2)
	Q52_TOTAL	0,000		Yes		43,348	0,000	2,04	2,23	-43,348	When the majority of time worked/week is between 22 and 45 hours (Q24, value 2), there is a positive relationship with the interruptions at work, which tend to not have consequences (Q52, value 2)

Tabla 6 (continuación)









Variable tested	Association with	Non-parametric inferential Statistics p_{value} (2-sided)										
		Wilcoxon Signed-Rank Test		H0 Hypothesis		Standardized Test statistics		MEAN		Z Test		
		Sig	Non-sig.	Reject	Accept	Value	Sig. (2-sided)	Var. 1	Var. 2	Value	Comments	
Variable 1  (idem)	Variable 2 Q54_TOTAL	0,000		Yes		120,958	0,000	2,04	4,68	-120,958		When the majority of time worked/week is between 22 and 45 hours (Q24, value 2), there is a positive relationship with the possibility of workers to change the amount of factors that define their work, which tend to be about work pace and the tasks' sequence (Q54, value 4 to 5)
 Q72_TOTAL		0,000		Yes		-154,738	0,000	2,04	0,11	-154,738		When the majority of time worked/week is between 22 and 45 hours (Q24, value 2), there is a clear negative relationship with the amount of worker's discriminations on the last 12 months, which tend to be inexistent (Q72, value 0)
 Q80_TOTAL		0,000		Yes		-150,999	0,000	2,04	0,24	-150,999		When the time worked/week is between 22 and 45 hours (Q24, value 2), there is a clear negative relationship with the amount of worker's offenses suffered along last month, which tend to be unexistent (Q80, value 0)
 Q81_TOTAL		0,000		Yes		-141,717	0,000	2,04	0,24	-141,717		When the majority of time worked/week is between 22 and 45 hours (Q24, value 2), there is a clear negative relationship with the amount of offenses taken as violence, sexual harassment and intimidation, which tend to be nonexistent (Q81, value 0)
 Q23_cat		0,000		Yes		-136,856	0,000	2,04	1,19	-136,856		When there is a majority of people working between 22 to 45 hours/week (Q24, value 2), there is a negative relationship with the amount os workers under supervision, which tend to be cero (Q23, value 1)
 Q48_TOTAL		0,000		Yes		-110,408	0,000	2,04	1,04	-110,408		When there is a majority of people working between 22 to 45 hours/week (Q24, value 2), there is a strong negative relationship with brief and repetitive tasks they may have, these ones tending to be of less than 1 minute (Q48, value 1)
 Q71_TOTAL		0,000		Yes		86,966	0,000	2,04	3,71	-86,966		When the majority of time worked/week is between 22 and 45 hours (Q24, value 2), there is an above-average positive relationship with the existing types of representation of the interests of respondent's company workers, whose tendency goes from having union and a delegate, till the occurrence of regular meetings (Q71, value 3 to 4)
 Q78_TOTAL		0,000		Yes		19,050	0,000	2,04	2,32	-19,050		When the majority of time worked/week is between 22 and 45 hours (Q24, value 2), there is a positive relationship with the amount of health issues the respondent may have suffered during last 12 months, that tending to be two types (Q78, value 2)

Tabla 6 (continuación)

Variable tested	Association with	Non-parametric inferential Statistics p_{value} (2-sided)									
		Wilcoxon Signed-Rank Test		Standardized Test statistics		MEAN		Z Test			
		Sig	Non-sig.	Reject	Accept	Value	Sig. (2-sided)	Var. 1	Var. 2	Value	Comments
Variable 1 Q26_cat	Variable 2 Q36_cat	0,000		Yes		-71,709	0,000	2,04	1,62	-71,709	When the number of days worked in each week are of five (Q26, value 2), there is an above-average negative relationship with the daily time spent to go to work and return home, which tends to take in total between more than 30 minutes and 30 minutes (Q36, value2 to 1)
	Q64_TOTAL	0,000		Yes		21,779	0,000	2,04	2,14	-21,779	When the number of days worked in each week are of five (Q26, value 2), there is a matching positive relationship with the possessed skills adjusted to accomplish the required tasks (Q64, value2)
	Q65_TOTAL	0,000		Yes		-114,564	0,000	2,04	0,96	-114,564	When the number of days worked in each week are of five (Q26, value 2), there is a strong negative relationship with the amount of training opportunities the worker benefits from, which tends to be of one single kind (Q65, value 1)
	Q42_TOTAL	0,000		Yes		-64,687	0,000	2,04	1,59	-64,687	When the number of days worked in each week are of five (Q26, value 2), there is an above-average negative relationship with the way how the employee's work schedule is organized, tending to become less elected by worker's criteria and more stipulated by organization, with no option for changes (Q42, value from 2 to 1)
	Q50_TOTAL	0,000		Yes		3,874	0,000	2,04	2,08	-3,874	When the number of days worked in each week are of five (Q26, value 2), there is no clarity on weak relationship with dependencies from work pace, which tends to become set around two kinds of dependency (Q50, value 2)
	Q52_TOTAL	0,000		Yes		41,045	0,000	2,04	2,08	-41,045	When the number of days worked in each week are of five (Q26, value 2), there is an above-average relationship with consequences of interruptions of work pace, which tends to become set as no consequences (Q52, value 2)
	Q54_TOTAL	0,000		Yes		120,594	0,000	2,04	4,68	-120,594	When the number of days worked in each week are of five (Q26, value 2), there is a strong positive relationship with the worker's ability to elect one or more ways change of the way he works, which tends to become set as electing its work pace and somehow extended to the sequence of tasks (Q54, value from 4 to 5)

Tabla 6 (continuación)









Variable tested	Association with	Non-parametric inferential Statistics p_{value} (2-sided)									
		Wilcoxon Signed-Rank Test		HO Hypothesis		Standardized Test statistics		MEAN		Z Test	
		Sig	Non-sig.	Reject	Accept	Value	Sig. (2-sided)	Var. 1	Var. 2	Value	Comments
Variable 1  (dem)	Variable 2  Q72_TOTAL	0,000		Yes		-153,331	0,000	2,04	0,11	-153,331	When the number of days worked in each week are of five (Q26, value 2), there is a strong negative relationship with the occurrence of some type(s) of discrimination that the respondent may have suffered in the last 12 months, which tends to become set to none (Q72, value 0)
 Q80_TOTAL		0,000		Yes		-149,162	0,000	2,04	0,24	-149,162	When the number of days worked in each week are of five (Q26, value 2), there is a strong negative relationship with the occurrence of some type(s) of offenses that the respondent may have suffered in the last 12 months, which tends to become set to none (Q80, value 0)
 Q81_TOTAL		0,000		Yes		-139,647	0,000	2,04	0,24	-139,647	When the number of days worked in each week are of five (Q26, value 2), there is a strong negative relationship with the occurrence of some type(s) of offenses, listed as verbal ones, sexual harassment, threats and humiliating behaviors, that the respondent may have suffered in the last month, which tends to become set to none (Q81, value 0)
 Q23_cat		0,000		Yes		-131,480	0,000	2,04	1,19	-131,480	When the number of days worked in each week are of five (Q26, value 2), there is a strong negative relationship with the amount of workers under respondent's supervision, which tends to become set to none (Q23, value 1)
 Q48_TOTAL		0,000		Yes		-109,368	0,000	2,04	1,04	-109,368	When the number of days worked in each week are of five (Q26, value 2), there is a strong negative relationship with the time spent to accomplish each of brief and repetitive tasks, which tend to be accomplished in less than 1 minute (Q48, value 1)
 Q71_TOTAL		0,000		Yes		85,624	0,000	2,04	3,71	-85,624	When the number of days worked in each week are of five (Q26, value 2), there is a strong positive relationship with the existence of representative structures for workers' defense, which tends to be that of union representation and delegate, extended to regular meetings (Q71, value between 3 and 4)
 Q78_TOTAL		0,000		Yes		18,733	0,000	2,04	2,32	-18,733	When the number of days worked in each week are of five (Q26, value 2), there is no clarity on the positive relationship with the existence of health problems arising from the work in the past 12 months, tending to attain the amount of two, from the listed options (Q78, value2)

Tabla 6 (continuación)

Variable tested	Association with	Non-parametric inferential Statistics <i>p</i> value (2-sided)					Z Test	Comments		
		Wilcoxon Signed-Rank Test	H0 Hypothesis	Standardized Test statistics	MEAN					
		Sig	Non-sig. Reject	Accept	Value	Sig. (2-sided)	Var. 1	Var. 2	Value	
Variable 1 Q36_cat	Variable 2 Q64_TOTAL	0,000	Yes		82,275	0,000	1,62	2,14	-82,275	When the daily time spent to go to work and come home is close or a bit above 31 minutes (Q36, value 1 to 2), there is a positive relationship with the skills of the worker, which tend to be adjusted to the tasks he must accomplish (Q64, value 2)
	Q65_TOTAL	0,000	Yes		-81,686	0,000	1,62	0,96	-81,686	When the daily time spent to go to work and come home is close or a bit above 31 minutes (Q36, value 1 to 2), there is an above-average negative relationship with the types of formation done during the last 12 months, that tends to be of one single kind (Q65, value 1)
	Q42_TOTAL	0,001	Yes		-3,256	0,001	1,62	1,59	-3,256	When the daily time spent to go to work and come home is close or a bit above 31 minutes (Q36, value 1 to 2), there is a weak negative relationship with the way the work schedule is settled, tending to be established between options of having a flexible work schedule, and the one fixed by company (Q42, value 2 to 1)
	Q50_TOTAL	0,000	Yes		51,558	0,000	1,62	2,08	-51,558	When the daily time spent to go to work and come home is close or a bit above 31 minutes (Q36, value 1 to 2), there is a positive relationship with the factors on which the work pace depends, which tend to increase (Q50, value 2)
	Q52_TOTAL	0,000	Yes		98,177	0,000	1,62	2,23	-98,177	When the daily time spent to go to work and come home is close or a bit above 31 minutes (Q36, value 1 to 2), there is a positive relationship with the interruptions at work, which tend to not have consequences (Q52, value 2)
	Q54_TOTAL	0,000	Yes		127,419	0,000	1,62	4,68	-127,419	When the daily time spent to go to work and come home is close or a bit above 31 minutes (Q36, value 1 to 2), there is a strong negative relationship with the possibility of workers to change the amount of factors of their work, whose trend departs from the work pace plus tasks' sequence , in direction to the only option, the work pace (Q54, value 5 to 4)

Tabla 6 (continuación)





Variable tested	Association with	Non-parametric inferential Statistics p_{value} (2-sided)									
		Wilcoxon Signed-Rank Test		H0 Hypothesis		Standardized Test statistics		MEAN		Z Test	
		Sig	Non-sig.	Reject	Accept	Value	Sig. (2-sided)	Var. 1	Var. 2	Value	Comments
Variable 1  (dem)	Variable 2 Q72_TOTAL	0,000		Yes		-147,590	0,000	1,62	0,11	-147,590	When the daily time spent to go to work and come home is close or a bit above 31 minutes (Q36, value 1 to 2), there is a strong negative relationship with the amount of worker's discriminations suffered during the last 12 months, whose trend is of not having suffered any discrimination (Q72, value 0)
 Q80_TOTAL		0,000		Yes		-138,811	0,000	1,62	0,24	-138,811	When the daily time spent to go to work and come home is close or a bit above 31 minutes (Q36, value 1 to 2), there is a strong negative relationship with the amount of worker's offenses during last month, whose trend is of not having suffered any kind of offenses (Q80, value 0)
 Q81_TOTAL		0,000		Yes		-130,079	0,000	1,62	0,24	-130,079	When the daily time spent to go to work and come home is close or a bit above 31 minutes (Q36, value 1 to 2), there is a strong negative relationship with the amount of worker's offenses, listed as verbal ones, sexual harassment, threats and humiliating behaviors, whose trend is of not having suffered any kind of incident (Q81, value 0)
 Q23_cat		0,000		Yes		-75,376	0,000	1,62	1,19	-75,376	When the daily time spent to go to work and come home is close or a bit above 31 minutes (Q36, value 1 to 2), there is a above-average negative relationship with the amount of workers under respondent's supervision, which tend to be zero (Q23, value 1)
 Q48_TOTAL		0,000		Yes		-61,489	0,000	1,62	1,04	-61,489	When the daily time spent to go to work and come home is close or a bit above 31 minutes (Q36, value 1 to 2), there is an above-average negative relationship with the time spent to accomplish each of brief and repetitive tasks, which tend to be accomplished in less than 1 minute (Q48, value 1)
 Q71_TOTAL		0,000		Yes		103,397	0,000	1,62	3,71	-103,397	When the daily time spent to go to work and come home is close or a bit above 31 minutes (Q36, value 1 to 2), there is a strong positive relationship with the amount of structures for workers's conditions defense, which tends to be that of union representation and delegate, extended to regular meetings (Q71, value 3 to 4)
 Q78_TOTAL		0,000		Yes		53,286	0,000	1,62	2,32	-53,286	When the daily time spent to go to work and come home is close or a bit above 31 minutes (Q36, value 1 to 2), there is a positive relationship with the health problems arising from the work in the past 12 months, which tends to be two types (Q78, value 2)

Tabla 6 (continuación)







Variable tested	Association with										Comments			
	Non-parametric inferential Statistics P_{value} (2-sided)													
	Wilcoxon Signed-Rank Test	H0 Hypothesis	Standardized Test statistics	MEAN	Z Test	Sig.	Non-sig.	Reject	Accept	Value		Sig. (2-sided)	Var. 1	Var. 2
Variable 1  Q64_TOTAL	0,000	Yes	-116,189	0,000	2,14	0,96				-116,189	0,000			When the possessed skills are adjusted to accomplish the required tasks (Q64, value2), there is a strong negative relationship with the amount of training opportunities the worker benefits from, which tends to be of one single kind (Q65, value 1)
 Q42_TOTAL	0,000	Yes	-74,525	0,000	2,14	1,59				-74,525	0,000			When the possessed skills are adjusted to accomplish the required tasks (Q64, value2), there is an above-average negative relationship with the way how the employee's work schedule is organized, tending to become less elected by worker's criteria and more stipulated by organization, with no option for changes (Q42, value from 2 to 1)
 Q50_TOTAL	0,000	Yes	-8,146	0,000	2,14	2,08				-8,146	0,000			When the possessed skills are adjusted to accomplish the required tasks (Q64, value2), there is no clarity on the negative weak relationship with dependencies from work pace, which tends to become set around two kinds of dependency (Q50, value 2)
 Q52_TOTAL	0,000	Yes	18,042	0,000	2,14	2,23				18,042	0,000			When the possessed skills are adjusted to accomplish the required tasks (Q64, value2), there is a relationship with the consequences of interrupting the work pace, which tends to become set as no consequences (Q52, value 2)
 Q54_TOTAL	0,000	Yes	118,726	0,000	2,14	4,68				118,726	0,000			When the possessed skills are adjusted to accomplish the required tasks (Q64, value2), there is a strong positive relationship with the worker's ability to elect one or more ways to change of the way he works, whose trend becomes set between the election of the pace of work, and the sequence of tasks and work pace (Q54, value from 4 to 5)
 Q72_TOTAL	0,000	Yes	-151,340	0,000	2,14	0,11				-151,340	0,000			When the possessed skills are adjusted to accomplish the required tasks (Q64, value2), there is a strong negative relationship with the occurrence of some type(s) of discrimination that the respondent may have suffered in the last 12 months, which tends to become set to none (Q72, value 0)
 Q80_TOTAL	0,000	Yes	-147,886	0,000	2,14	0,24				-147,886	0,000			When the possessed skills are adjusted to accomplish the required tasks (Q64, value2), there is a strong negative relationship with the occurrence of some type(s) of offenses the respondent may have suffered in the last month, which tends to become set to none (Q80, value 0)

Tabla 6 (continuación)







Variable tested	Association with	Non-parametric inferential Statistics p value (2-sided)									
		Wilcoxon Signed-Rank Test		H0 Hypothesis		Standardized Test statistics		MEAN		Z Test	
		Sig	Non-sig.	Reject	Accept	Value	Sig. (2-sided)	Var. 1	Var. 2	Value	Value
Variable 1  (idem)	Variable 2  Q81_TOTAL	0,000		Yes		-140,128	0,000	2,14	0,24	-140,128	When the possessed skills are adjusted to accomplish the required tasks (Q64, value2), there is a strong negative relationship with the amount of offenses the worker may have suffered during the last 12 months, listed as verbal ones, sexual harassment, threats and humiliating behaviors, whose trend is of not having suffered any kind of incident (Q81, value 0)
	 Q23_cat	0,000		Yes		-129,487	0,000	2,14	1,19	-129,487	When the possessed skills are adjusted to accomplish the required tasks (Q64, value2), there is a strong negative relationship with the amount of workers under respondent's supervision, which tends to become set to none (Q23, value 1)
	 Q48_TOTAL	0,000		Yes		-111,178	0,000	2,14	1,04	-111,178	When the possessed skills are adjusted to accomplish the required tasks (Q64, value2), there is a strong negative relationship with the time spent to accomplish each of brief and repetitive tasks, which tend to be accomplished in less than 1 minute (Q48, value 1)
	 Q71_TOTAL	0,000		Yes		83,213	0,000	2,14	3,71	-83,213	When the possessed skills are adjusted to accomplish the required tasks (Q64, value2), there is a strong positive relationship with the amount of structures for workers's conditions defense, which tends to be that of union representation and delegate, extended to regular meetings (Q71, value 3 to 4)
	 Q78_TOTAL	0,000		Yes		10,186	0,000	2,14	2,32	-10,186	When the possessed skills are adjusted to accomplish the required tasks (Q64, value2), there is no clarity on the positive relationship with the existence of health problems arising from the work in the past 12 months, tending to attain the amount of two, from the listed options (Q78, value2)

Tabla 6 (continuación)

Variable tested	Association with	Non-parametric inferential Statistics p_{value} (2-sided)										Comments
		Wilcoxon Signed-Rank Test		Standardized Test statistics		MEAN		Z Test				
		Sig	Non-sig.	Reject H0	Accept	Value	Sig. (2-sided)	Var. 1	Var. 2	Value	Z Test	
Variable 1 (idem)	Variable 2 Q23_cat	0,000		Yes		36,127	0,000	0,96	1,19	-36,127		When the worker benefits from one kind of training opportunities (Q65, value 1), there is no clarity on the positive relationship with the amount of workers under respondent's supervision, which tends to become set to none (Q23, value 1)
	Q48_TOTAL	0,000		Yes		10,710	0,000	0,96	1,04	-10,710		When the worker benefits from one kind of training opportunities (Q65, value 1), there is no clarity on the positive relationship with the time spent to accomplish each of brief and repetitive tasks, which tend to be accomplished in less than 1 minute (Q48, value 1)
	Q71_TOTAL	0,000		Yes		124,258	0,000	0,96	3,71	-124,258		When the worker benefits from one kind of training opportunities (Q65, value 1), there is a strong positive relationship with the existence of representative structures for workers' defense, which tends to be that of union representation and delegate, extended to regular meetings (Q71, value between 3 and 4)
	Q78_TOTAL	0,000		Yes		91,435	0,000	0,96	2,32	-91,435		When the worker benefits from one kind of training opportunities (Q65, value 1), there is a strong positive relationship with the existence of health problems arising from the work in the past 12 months, tending to attain the amount of two, from the listed options (Q78, value2)

Tabla 6 (continuación)

Variable tested	Association with	Non-parametric inferential Statistics p_{value} (2-sided)							Comments		
		Wilcoxon Signed-Rank Test		Standardized Test statistics		MEAN		Z Test			
		Sig	Non-sig.	Reject H0	Accept H0	Value	Sig. (2-sided)	Var. 1		Var. 2	Value
Variable 1 Q42_TOTAL	Variable 2 Q50_TOTAL	0,000		Yes		49,587	0,000	1,59	2,08	-49,587	When the way how the employee's work schedule tends to become more flexible (Q42 value 1 to 2), it emerges a positive relationship with dependencies from work pace, which tends to become set around two kinds of dependency (Q50, value 2)
	Q52_TOTAL	0,000		Yes		88,124	0,000	1,59	2,23	-88,124	When the way how the employee's work schedule tends to become more flexible (Q42 value 1 to 2), it emerges a strong positive relationship with consequences of interruptions of work pace, which tends to become set as no consequences (Q52, value 2)
	Q54_TOTAL	0,000		Yes		130,516	0,000	1,59	4,68	-130,516	When the way how the employee's work schedule tends to become more flexible (Q42 value 1 to 2), it emerges a strong positive relationship with the worker's ability to elect one or more ways change of the way he works, which tends to become set as electing its work pace and somehow extended to the sequence of tasks (Q54, value from 4 to 5)
	Q72_TOTAL	0,000		Yes		-148,658	0,000	1,59	0,11	-148,658	When the way how the employee's work schedule tends to become more flexible (Q42 value 1 to 2), it emerges a strong negative relationship with the occurrence of some type(s) of discrimination that the respondent may have suffered in the last 12 months, which tends to become set to none (Q72, value 0)
	Q80_TOTAL	0,000		Yes		-136,651	0,000	1,59	0,24	-136,651	When the way how the employee's work schedule tends to become more flexible (Q42 value 1 to 2), it emerges a strong negative relationship with the occurrence of some type(s) of offenses that the respondent may have suffered in the last month, which tends to become set to none (Q80, value 0)

Tabla 6 (continuación)





Variable tested	Association with	Non-parametric inferential Statistics p_{value} (2-sided)						Comments			
		Wilcoxon Signed-Rank Test	H0 Hypothesis	Standardized Test statistics	MEAN	Z Test					
		Sig.	Non-sig.	Reject	Accept	Value	Sig. (2-sided)	Var. 1	Var. 2	Value	
Variable 1  (idem)	Variable 2 Q81_TOTAL	0,000		Yes		-131,876	0,000	1,59	0,24	-131,876	When the way how the employee's work schedule tends to become more flexible (Q42 value 1 to 2), it emerges a strong negative relationship with the amount of offenses the worker may have suffered during the last 12 months, listed as verbal ones, sexual harassment, threats and humiliating behaviors, whose trend is of not having suffered any kind of incident (Q81, value 0)
 Q23_cat		0,000		Yes		-65,598	0,000	1,59	1,19	-65,598	When the way how the employee's work schedule tends to become more flexible (Q42 value 1 to 2), it emerges a negative relationship with the amount of workers under respondent's supervision, which tends to become set to none (Q23, value 1)
 Q48_TOTAL		0,000		Yes		-48,226	0,000	1,59	1,04	-48,226	When the way how the employee's work schedule tends to become more flexible (Q42 value 1 to 2), it emerges a negative relationship with the time spent to accomplish each of brief and repetitive tasks, which tend to be accomplished in less than 1 minute (Q48, value 1)
 Q71_TOTAL		0,000		Yes		104,998	0,000	1,59	3,71	-104,998	When the way how the employee's work schedule tends to become more flexible (Q42 value 1 to 2), it emerges a strong positive relationship with the existence of representative structures for workers' defense, which tends to be that of union representation and delegate, extended to regular meetings (Q71, value between 3 and 4)
 Q78_TOTAL		0,000		Yes		53,378	0,000	1,59	2,32	-53,378	When the way how the employee's work schedule tends to become more flexible (Q42 value 1 to 2), it emerges an above-average positive relationship with the existence of health problems arising from the work in the past 12 months, tending to attain the amount of two, from the listed options (Q78, value 2)

Tabla 6 (continuación)









Variable tested	Association with	Non-parametric inferential Statistics P value (2-sided)													
		Wilcoxon Signed-Rank Test		Standardized Test statistics		MEAN		Z Test							
		Sig	Non-sig.	Reject	Accept	Value	Sig. (2-sided)	Var. 1	Var. 2	Value	Comments				
Variable 1	Variable 2														
 Q50_TOTAL	 Q52_TOTAL	0,000		Yes		19,590	0,000	2,08	2,23	-19,590				When the dependencies from work pace tend to become set around two kinds of dependency (Q50, value 2), it emerges a weak positive relationship with the consequences of interruption of the work pace, which tends to become set as no consequences (Q52, value 2)	
 Q54_TOTAL	 Q54_TOTAL	0,000		Yes		111,252	0,000	2,08	4,68	-111,252				When the dependencies from work pace tend to become set around two kinds of dependency (Q50, value 2), it emerges a strong positive relationship with the worker's ability to elect one or more ways change of the way he works, which tends to become set as electing its work pace and somehow extended to the sequence of tasks (Q54, value from 4 to 5)	
 Q72_TOTAL	 Q72_TOTAL	0,000		Yes		-139,762	0,000	2,08	0,11	-139,762				When the dependencies from work pace tend to become set around two kinds of dependency (Q50, value 2), it emerges a strong negative relationship with the occurrence of some type(s) of discrimination that the respondent may have suffered in the last 12 months, which tends to become set to none (Q72, value 0)	
 Q80_TOTAL	 Q80_TOTAL	0,000		Yes		-135,643	0,000	2,08	0,24	-135,643				When the dependencies from work pace tend to become set around two kinds of dependence (Q50, value 2), it emerges a strong negative relationship with the occurrence of some type(s) of offenses that the respondent may have suffered in the last 12 months, which tends to become set to none (Q80, value 0)	

Tabla 6 (continuación)

Variable tested	Association with	Non-parametric inferential Statistics p_{value} (2-sided)													
		Wilcoxon Signed-Rank Test					Standardized Test statistics								
		H0 Hypothesis	Reject	Accept	Value	Sig. (2-sided)	Var. 1	Var. 2	MEAN	Z Test	Value				
Variable 1 Q81_TOTAL	Q81_TOTAL	Yes	Yes	No	-129,618	0,000	2,08	0,24	-129,618						When the dependencies from work pace tend to become set around two kinds of dependency (Q50, value 2), it emerges a strong negative relationship with the amount of offenses the worker may have suffered during the last 12 months, listed as verbal ones, sexual harassment, threats and humiliating behaviors, whose trend is of not having suffered any kind of incident (Q81, value 0)
Q23_cat	Q23_cat	Yes	Yes	No	-95,792	0,000	2,08	1,19	-95,792						When the dependencies from work pace tend to become set around two kinds of dependency (Q50, value 2), it emerges a strong negative relationship with the amount of workers under respondent's supervision, which tends to become set to none (Q23, value 1)
Q48_TOTAL	Q48_TOTAL	Yes	Yes	No	-93,680	0,000	2,08	1,04	-93,680						When the dependencies from work pace tend to become set around two kinds of dependency (Q50, value 2), it emerges a strong negative relationship with the time spent to accomplish each of brief and repetitive tasks, which tend to be accomplished in less than 1 minute (Q48, value 1)
Q71_TOTAL	Q71_TOTAL	Yes	Yes	No	82,722	0,000	2,08	3,71	82,722						When the dependencies from work pace tend to become set around two kinds of dependency (Q50, value 2), it emerges a strong positive relationship with the existence of representative structures for workers' defense, which tends to be that of union representation and delegate, extended to regular meetings (Q71, value between 3 and 4)
Q78_TOTAL	Q78_TOTAL	Yes	Yes	No	16,788	0,000	2,08	2,32	16,788						When the dependencies from work pace tend to become set around two kinds of dependency (Q50, value 2), it emerges a weak positive relationship with the existence of health problems arising from the work in the past 12 months, tending to attain the amount of two, from the listed options (Q78, value2)

Tabla 6 (continuación)

Variable tested	Association with		Non-parametric inferential Statistics p_{value} (2-sided)				Z Test	Comments		
	Wilcoxon Signed-Rank Test	H0 Hypothesis	Standardized Test statistics		MEAN					
			Sig.	Sig. (2-sided)						
	Sig.	Non-sig.	Reject	Accept	Value	Sig. (2-sided)	Var. 1	Var. 2	Value	
Variable 1 Q52_TOTAL	0,000		Yes		118,069	0,000	2,23	4,68	-118,069	When consequences of interruptions of work pace tends to become set as no consequences (Q52, value 2), there is a strong positive relationship with the worker's ability to elect one or more ways to change the way he works, which tends to become set as electing its work pace and somehow extended to the sequence of tasks (Q54, value from 4 to 5)
Q72_TOTAL	0,000		Yes		-153,754	0,000	2,23	0,11	-153,754	When consequences of interruptions of work pace tends to become set as no consequences (Q52, value 2), there is a strong negative relationship with the occurrence of some type(s) of discrimination that the respondent may have suffered in the last 12 months, which tends to become set to none (Q72, value 0)
Q80_TOTAL	0,000		Yes		-152,172	0,000	2,23	0,24	-152,172	When consequences of interruptions of work pace tends to become set as no consequences (Q52, value 2), there is a strong negative relationship with the occurrence of some type(s) of offenses that the respondent may have suffered in the last month, which tends to become set to none (Q80, value 0)
Q81_TOTAL	0,000		Yes		-146,394	0,000	2,23	0,24	-146,394	When consequences of interruptions of work pace tends to become set as no consequences (Q52, value 2), there is a strong negative relationship with the occurrence of some type(s) of offenses, listed as verbal ones, sexual harassment, threats and humiliating behaviors, that the respondent may have suffered in the last 12 months, which tends to become set to none (Q81, value 0)
Q23_cat	0,000		Yes		-139,843	0,000	2,23	1,19	-139,843	When consequences of interruptions of work pace tends to become set as no consequences (Q52, value 2), there is a strong negative relationship with the amount of workers under respondent's supervision, which tends to become set to none (Q23, value 1)
Q48_TOTAL	0,000		Yes		-118,857	0,000	2,23	1,04	-118,857	When consequences of interruptions of work pace tends to become set as no consequences (Q52, value 2), there is a strong negative relationship with the time spent to accomplish each of brief and repetitive tasks, which tend to be accomplished in less than 1 minute (Q48, value 1)
Q71_TOTAL	0,000		Yes		81,734	0,000	2,23	3,71	-81,734	When consequences of interruptions of work pace tends to become set as no consequences (Q52, value 2), there is a strong positive relationship with the existence of representative structures for workers' defense, which tends to be that of union representation and delegate, extended to regular meetings (Q71, value between 3 and 4)
Q78_TOTAL	0,000		Yes		3,981	0,000	2,23	2,32	-3,981	When consequences of interruptions of work pace tends to become set as no consequences (Q52, value 2), there is no clarity on the very weak positive relationship with the existence of health problems arising from the work in the past 12 months, tending to attain the amount of two, from the listed options (Q78, value2)

Tabla 6 (continuación)

Variable tested	Association with	Non-parametric inferential Statistics p_{value} (2-sided)					Z Test	Comments			
		Wilcoxon Signed-Rank Test	H0 Hypothesis	Standardized Test statistics	MEAN						
		Sig	Non-sig.	Reject	Accept	Value			Sig. (2-sided)	Var. 1	Var. 2
Variable 1 Q54_TOTAL	Variable 2 Q72_TOTAL	0,000		Yes		-138,938	0,000	4,68	0,11	-138,938	With the worker's ability in changing the factors about the way he works, by electing its work pace and this one added to the sequence of tasks (Q54, value from 4 to 5), it emerges a strong negative relationship with the occurrence of some type(s) of discrimination that the respondent may have suffered in the last 12 months, which tends to become set to none (Q72, value 0)
	Q80_TOTAL	0,000		Yes		-138,336	0,000	4,68	0,24	-138,336	With the worker's ability in changing the factors about the way he works, by electing its work pace and this one added to the sequence of tasks (Q54, value from 4 to 5), it emerges a strong negative relationship with the occurrence of some type(s) of offenses that the respondent may have suffered in the last month, which tends to become set to none (Q80, value 0)
	Q81_TOTAL	0,000		Yes		-137,124	0,000	4,68	0,24	-137,124	With the worker's ability in changing the factors about the way he works, by electing its work pace and this one added to the sequence of tasks (Q54, value from 4 to 5), it emerges a strong negative relationship with the occurrence of some type(s) of offenses, listed as verbal ones, sexual harassment, threats and humiliating behaviors, that the respondent may have suffered in the last 12 months, which tends to become set to none (Q81, value 0)
	Q23_cat	0,000		Yes		-134,679	0,000	4,68	1,19	-134,679	With the worker's ability in changing the factors about the way he works, by electing its work pace and this one added to the sequence of tasks (Q54, value from 4 to 5), it emerges a strong negative relationship with the amount of workers under respondent's supervision, which tends to become set to none (Q23, value 1)
	Q48_TOTAL	0,000		Yes		-131,182	0,000	4,68	1,04	-131,182	With the worker's ability in changing the factors about the way he works, by electing its work pace and this one added to the sequence of tasks (Q54, value from 4 to 5), it emerges a strong negative relationship with the time spent to accomplish each of brief and repetitive tasks, which tend to be accomplished in less than 1 minute (Q48, value 1)
	Q71_TOTAL	0,000		Yes		-43,762	0,000	4,68	3,71	-43,762	With the worker's ability in changing the factors about the way he works, by electing its work pace and this one added to the sequence of tasks (Q54, value from 4 to 5), it emerges a negative relationship with the existence of representative structures for workers' defense, which tends to be regular meetings, extended to that of union representation and delegate (Q71, value between 4 and 3)
	Q78_TOTAL	0,000		Yes		-98,737	0,000	4,68	2,32	-98,737	With the worker's ability in changing the factors about the way he works, by electing its work pace and this one added to the sequence of tasks (Q54, value from 4 to 5), it emerges a strong negative relationship with the existence of health problems arising from the work in the past 12 months, tending to attain the amount of two, from the listed options (Q78, value2)

Tabla 6 (continuación)







Variable tested	Association with	Non-parametric inferential Statistics p_{value} (Z-sided)					Comments			
		Wilcoxon Signed-Rank Test	H0 Hypothesis	Standardized Test statistics	MEAN	Z Test				
		Sig	Non-sig. Reject	Accept	Value	Sig. (2-sided)	Var. 1	Var. 2	Value	
Variable 1										
	Q72_TOTAL	0,000	Yes	Yes	33,361	0,000	0,11	0,24	-33,361	When the occurrence of some type(s) of discrimination that respondent may have suffered in the last 12 months tends to become set as none (Q72, value 0), there is a positive relationship with the non-occurrence of any type(s) of offenses for the respondent in the same period (Q80, value 0)
Variable 2										
	Q81_TOTAL	0,000	Yes	Yes	20,904	0,000	0,11	0,24	-20,904	When the occurrence of some type(s) of discrimination that the respondent may have suffered in the last 12 months tends to become set to none (Q72, value 0), there is a positive relationship with the occurrence of some type(s) of offenses, listed as verbal ones, sexual harassment, threats and humiliating behaviors, that the respondent may have suffered in the last month, which tends to become set to none (Q81, value 0)
	Q23_cat	0,000	Yes	Yes	151,128	0,000	0,11	1,19	-151,128	When the occurrence of some type(s) of discrimination that the respondent may have suffered in the last 12 months tends to become set to none (Q72, value 0), there is a strong positive relationship with the amount of workers under respondent's supervision, which tends to become set to none (Q23, value 1)
	Q48_TOTAL	0,000	Yes	Yes	96,700	0,000	0,11	1,04	-96,700	When the occurrence of some type(s) of discrimination that the respondent may have suffered in the last 12 months tends to become set to none (Q72, value 0), there is a strong positive relationship with the time spent to accomplish each of brief and repetitive tasks, which tend to be accomplished in less than 1 minute (Q48, value 1)
	Q71_TOTAL	0,000	Yes	Yes	130,217	0,000	0,11	3,71	-130,217	When the occurrence of some type(s) of discrimination that the respondent may have suffered in the last 12 months tends to become set to none (Q72, value 0), there is a strong positive relationship with the existence of representative structures for workers' defense, which tends to be that of union representation and delegate, extended to regular meetings (Q71, value between 3 and 4)
	Q78_TOTAL	0,000	Yes	Yes	128,483	0,000	0,11	2,32	-128,493	When the occurrence of some type(s) of discrimination that the respondent may have suffered in the last 12 months tends to become set to none (Q72, value 0), there is a strong positive relationship with the existence of health problems arising from the work in the past 12 months, tending to attain the amount of two, from the listed options (Q78, value2)

Tabla 6 (continuación)





Variable tested	Association with	Non-parametric inferential Statistics $P_{variable}$ (2-sided)										
		Wilcoxon Signed-Rank Test		Standardized Test statistics		MEAN		Z Test		Comments		
		Sig	Non-sig.	Reject	Accept	Value	Sig. (2-sided)	Var. 1	Var. 2	Value	Value	
Variable 1  Q80_TOTAL	Variable 2 Q81_TOTAL	0,000		Yes		-4,029	0,000	0,24	0,24	-4,029		When there exist no occurrence of any type(s) of offenses the respondent may have suffered during the last month (Q80, value 0), there is a very weak negative relationship with the non-occurrence of offenses during in last 12 months (of verbal offenses, sexual harassment, threats and humiliating behaviors) (Q81, value 0)
 Q23_cat		0,000		Yes		132,998	0,000	0,24	1,19	-132,998		When there exist no occurrence of any type(s) of offenses the respondent may have suffered during the last month (Q80, value 0), there is a strong positive relationship with the amount of workers under respondent's supervision, which tends to become set to none (Q23, value 1)
 Q48_TOTAL		0,000		Yes		85,800	0,000	0,24	1,04	-85,800		When there exist no occurrence of any type(s) of offenses the respondent may have suffered during the last month (Q80, value 0), there is a strong positive relationship with the time spent to accomplish each of brief and repetitive tasks, which tend to be accomplished in less than 1 minute (Q48, value 1)
 Q71_TOTAL		0,000		Yes		129,447	0,000	0,24	3,71	-129,447		When there exist no occurrence of any type(s) of offenses the respondent may have suffered during the last month (Q80, value 0), there is a strong positive relationship with the existence of representative structures for workers' defense, which tends to be that of union representation and delegate, extended to regular meetings (Q71, value between 3 and 4)
 Q78_TOTAL		0,000		Yes		126,480	0,000	0,24	2,32	-126,480		When there exist no occurrence of any type(s) of offenses the respondent may have suffered during the last month (Q80, value 0), there is a strong positive relationship with the existence of health problems arising from the work in the past 12 months, tending to attain the amount of two, from the listed options (Q78, value2)

Tabla 6 (continuación)

Variable tested	Association with	Non-parametric inferential Statistics p_{value} (2-sided)				Z Test	Comments			
		Wilcoxon Signed-Rank Test	H0 Hypothesis	Standardized Test statistics	MEAN					
		Sig	Non-sig. Reject	Accept	Value	Sig. (2-sided)	Var. 1	Var. 2	Value	
Variable 1 Q81_TOTAL	Variable 2 Q23_cat	0,000	Yes		129,423	0,000	0,24	1,19	-129,423	When there exist no occurrence of any of the listed offenses that the respondent may have suffered in the last 12 months (verbal ones, sexual harassment, threats and humiliating behaviors) (Q81, value 0), there is a strong positive relationship with the amount of workers under respondent's supervision, which tends to become set to none (Q23, value 1)
Q48_TOTAL		0,000	Yes		76,370	0,000	0,24	1,04	-76,370	When there exist no occurrence of any of the listed offenses that the respondent may have suffered in the last 12 months (verbal ones, sexual harassment, threats and humiliating behaviors) (Q81, value 0), there is a strong positive relationship with the time spent to accomplish each of brief and repetitive tasks, which tend to be accomplished in less than 1 minute (Q48, value 1)
Q71_TOTAL		0,000	Yes		126,975	0,000	0,24	3,71	-126,975	When there exist no occurrence of any of the listed offenses that the respondent may have suffered in the last 12 months (verbal ones, sexual harassment, threats and humiliating behaviors) (Q81, value 0), there is a strong positive relationship with the existence of representative structures for workers' defense, which tends to be that of union representation and delegate, extended to regular meetings (Q71, value between 3 and 4)
Q78_TOTAL		0,000	Yes		123,595	0,000	0,24	2,32	-123,595	When there exist no occurrence of any of the listed offenses that the respondent may have suffered in the last 12 months (verbal ones, sexual harassment, threats and humiliating behaviors) (Q81, value 0), there is a strong positive relationship the existence of health problems arising from the work in the past 12 months, tending to attain the amount of two, from the listed options (Q78, value2)

Tabla 6 (continuación)







Variable tested	Association with	Non-parametric inferential Statistics p_{value} (2-sided)					Z Test	Comments		
		Wilcoxon Signed-Rank Test	H0 Hypothesis	Standardized Test statistics	MEAN					
		Sig	Non-sig. Reject	Accept	Value	Sig. (2-sided)	Var. 1	Var. 2	Value	
Variable 1	Variable 2									
 Q23_cat	 Q48_TOTAL	0,000	Yes		-13,311	0,000	1,19	1,04	-13,311	When the amount of workers under respondent's supervision tends to become set to none (Q23, value 1), there is a weak negative relationship with the time spent to accomplish each of brief and repetitive tasks, which tend to be accomplished in less than 1 minute (Q48, value 1)
 Q71_TOTAL	 Q71_TOTAL	0,000	Yes		117,356	0,000	1,19	3,71	-117,356	When the amount of workers under respondent's supervision tends to become set to none (Q23, value 1), there is a strong positive relationship with the existence of representative structures for workers' defense, which tends to be that of union representation and delegate, extended to regular meetings (Q71, value between 3 and 4)
 Q78_TOTAL	 Q78_TOTAL	0,000	Yes		84,250	0,000	1,19	2,32	-84,250	When the amount of workers under respondent's supervision tends to become set to none (Q23, value 1), there is an above average positive relationship with the existence of health problems arising from the work in the past 12 months, tending to attain the amount of two, from the listed options (Q78, value2)
 Q48_TOTAL	 Q71_TOTAL	0,000	Yes		114,352	0,000	1,04	3,71	-114,352	When the time spent to accomplish each of brief and repetitive tasks tends to be accomplished in less than 1 minute (Q48, value 1), there is a strong positive relationship with the existence of representative structures for workers' defense, which tends to be that of union representation and delegate, extended to regular meetings (Q71, value between 3 and 4)
 Q78_TOTAL	 Q78_TOTAL	0,000	Yes		86,110	0,000	1,04	2,32	-86,110	When the time spent to accomplish each of brief and repetitive tasks tends to be accomplished in less than 1 minute (Q48, value 1), there is an above average positive relationship with the existence of health problems arising from the work in the past 12 months, tending to attain the amount of two, from the listed options (Q78, value2)
 Q71_TOTAL	 Q78_TOTAL	0,000	Yes		-65,170	0,000	3,71	2,32	-65,170	When the existence of representative structures for workers' defense tends to be that of union representation and delegate, extended to regular meetings (Q71, value between 3 and 4), there is an above-average negative relationship with the existence of health problems arising from the work in the past 12 months, tending to attain the amount of two, from the listed options (Q78, value2)

Tabla 7. Asociaciones intra-grupo entre variables cualitativas y de escala**INTRA-GROUP ASSOCIATIONS BETWEEN QUALITATIVE AND SCALE VARIABLES**

GROUP	Variables		ETA	Comments	Explained Variance
	Dependent	Independent	value		
Results & Effects	Q45a_inv	Q78a_dic_MV	0,058	Small relation	0,34%
		Q78b_dic_MV	0,091	Small relation	0,83%
		Q78c_dic_MV	0,111	Small relation	1,23%
		Q78d_dic_MV	0,138	MODERATE RELATION	1,90%
		Q78e_dic_MV	0,092	Small relation	0,85%
		Q78f_dic_MV	0,171	MODERATE RELATION	2,92%
		Q78g_dic_MV	0,052	Small relation	0,27%
		Q78h_dic_MV	0,244	MODERATE RELATION	5,95%
		Q78i_dic_MV	0,222	MODERATE RELATION	4,93%
Results & Effects	Q45b_inv	Q78a_dic_MV	0,050	Small relation	0,25%
		Q78b_dic_MV	0,087	Small relation	0,76%
		Q78c_dic_MV	0,220	MODERATE RELATION	4,84%
		Q78d_dic_MV	0,240	MODERATE RELATION	5,76%
		Q78e_dic_MV	0,224	MODERATE RELATION	5,02%
		Q78f_dic_MV	0,214	MODERATE RELATION	4,58%
		Q78g_dic_MV	0,072	Small relation	0,52%
		Q78h_dic_MV	0,221	MODERATE RELATION	4,88%
		Q78i_dic_MV	0,347	STRONG RELATION	12,04%
Results & Effects	Q45c_inv	Q78a_dic_MV	0,037	Small relation	0,14%
		Q78b_dic_MV	0,083	Small relation	0,69%
		Q78c_dic_MV	0,143	MODERATE RELATION	2,04%
		Q78d_dic_MV	0,160	MODERATE RELATION	2,56%
		Q78e_dic_MV	0,141	MODERATE RELATION	1,99%
		Q78f_dic_MV	0,157	MODERATE RELATION	2,46%
		Q78g_dic_MV	0,065	Small relation	0,42%
		Q78h_dic_MV	0,173	MODERATE RELATION	2,99%
		Q78i_dic_MV	0,241	MODERATE RELATION	5,81%
Results & Effects	Q45d_inv	Q78a_dic_MV	0,024	Small relation	0,06%
		Q78b_dic_MV	0,055	Small relation	0,30%
		Q78c_dic_MV	0,100	Small relation	1,00%
		Q78d_dic_MV	0,101	Small relation	1,02%
		Q78e_dic_MV	0,088	Small relation	0,77%
		Q78f_dic_MV	0,129	Small relation	1,66%
		Q78g_dic_MV	0,043	Small relation	0,18%
		Q78h_dic_MV	0,138	MODERATE RELATION	1,90%
		Q78i_dic_MV	0,157	MODERATE RELATION	2,46%
Results & Effects	Q45e_inv	Q78a_dic_MV	0,010	NO ASSOCIATION	0,01%
		Q78b_dic_MV	0,026	Small relation	0,07%
		Q78c_dic_MV	0,051	Small relation	0,26%
		Q78d_dic_MV	0,064	Small relation	0,41%
		Q78e_dic_MV	0,059	Small relation	0,35%
		Q78f_dic_MV	0,077	Small relation	0,59%
		Q78g_dic_MV	0,030	Small relation	0,09%
		Q78h_dic_MV	0,092	Small relation	0,85%
		Q78i_dic_MV	0,109	Small relation	1,19%

Tabla 7 (continuación)

INTRA-GROUP ASSOCIATIONS BETWEEN QUALITATIVE AND SCALE VARIABLES

GROUP	Variables		ETA	Comments	Explained Variance
	Dependent	Independent	value		
Results & Effects	Q79a_inv	Q78a_dic_MV	0,079	Small relation	0,62%
		Q78b_dic_MV	0,112	Small relation	1,25%
		Q78c_dic_MV	0,208	MODERATE RELATION	4,33%
		Q78d_dic_MV	0,223	MODERATE RELATION	4,97%
		Q78e_dic_MV	0,203	MODERATE RELATION	4,12%
		Q78f_dic_MV	0,230	MODERATE RELATION	5,29%
		Q78g_dic_MV	0,090	Small relation	0,81%
		Q78h_dic_MV	0,257	MODERATE RELATION	6,60%
		Q78i_dic_MV	0,261	STRONG RELATION	6,81%
Results & Effects	Q79b_inv	Q78a_dic_MV	0,118	Small relation	1,39%
		Q78b_dic_MV	0,130	MODERATE RELATION	1,69%
		Q78c_dic_MV	0,221	MODERATE RELATION	4,88%
		Q78d_dic_MV	0,248	MODERATE RELATION	6,15%
		Q78e_dic_MV	0,222	MODERATE RELATION	4,93%
		Q78f_dic_MV	0,214	MODERATE RELATION	4,58%
		Q78g_dic_MV	0,098	Small relation	0,96%
		Q78h_dic_MV	0,241	MODERATE RELATION	5,81%
		Q78i_dic_MV	0,258	MODERATE RELATION	6,66%
Results & Effects	Q79c_inv	Q78a_dic_MV	0,082	Small relation	0,67%
		Q78b_dic_MV	0,147	MODERATE RELATION	2,16%
		Q78c_dic_MV	0,254	MODERATE RELATION	6,45%
		Q78d_dic_MV	0,285	STRONG RELATION	8,12%
		Q78e_dic_MV	0,262	STRONG RELATION	6,86%
		Q78f_dic_MV	0,284	STRONG RELATION	8,07%
		Q78g_dic_MV	0,104	Small relation	1,08%
		Q78h_dic_MV	0,301	STRONG RELATION	9,06%
		Q78i_dic_MV	0,387	STRONG RELATION	14,98%
Results & Effects	Q87a_inv	Q78a_dic_MV	0,048	Small relation	0,23%
		Q78b_dic_MV	0,077	Small relation	0,59%
		Q78c_dic_MV	0,176	MODERATE RELATION	3,10%
		Q78d_dic_MV	0,169	MODERATE RELATION	2,86%
		Q78e_dic_MV	0,170	MODERATE RELATION	2,89%
		Q78f_dic_MV	0,160	MODERATE RELATION	2,56%
		Q78g_dic_MV	0,058	Small relation	0,34%
		Q78h_dic_MV	0,229	MODERATE RELATION	5,24%
		Q78i_dic_MV	0,238	MODERATE RELATION	5,66%
Results & Effects	Q87b_inv	Q78a_dic_MV	0,060	Small relation	0,36%
		Q78b_dic_MV	0,116	Small relation	1,35%
		Q78c_dic_MV	0,203	MODERATE RELATION	4,12%
		Q78d_dic_MV	0,208	MODERATE RELATION	4,33%
		Q78e_dic_MV	0,182	MODERATE RELATION	3,31%
		Q78f_dic_MV	0,200	MODERATE RELATION	4,00%
		Q78g_dic_MV	0,070	Small relation	0,49%
		Q78h_dic_MV	0,285	STRONG RELATION	8,12%
		Q78i_dic_MV	0,281	STRONG RELATION	7,90%
Results & Effects	Q88_inv	Q78a_dic_MV	0,050	Small relation	0,25%
		Q78b_dic_MV	0,078	Small relation	0,61%
		Q78c_dic_MV	0,179	MODERATE RELATION	3,20%
		Q78d_dic_MV	0,174	MODERATE RELATION	3,03%
		Q78e_dic_MV	0,180	MODERATE RELATION	3,24%
		Q78f_dic_MV	0,121	Small relation	1,46%
		Q78g_dic_MV	0,067	Small relation	0,45%
		Q78h_dic_MV	0,182	MODERATE RELATION	3,31%
		Q78i_dic_MV	0,221	MODERATE RELATION	4,88%

Tabla 7 (continuación)

INTRA-GROUP ASSOCIATIONS BETWEEN QUALITATIVE AND SCALE VARIABLES

GROUP	Variables		ETA	Comments	Explained Variance
	Dependent	Independent	value		
Results & Effects	Q61m_inv	Q78a_dic_MV	0,046	Small relation	0,21%
		Q78b_dic_MV	0,081	Small relation	0,66%
		Q78c_dic_MV	0,137	MODERATE RELATION	1,88%
		Q78d_dic_MV	0,155	MODERATE RELATION	2,40%
		Q78e_dic_MV	0,111	Small relation	1,23%
		Q78f_dic_MV	0,158	MODERATE RELATION	2,50%
		Q78g_dic_MV	0,056	Small relation	0,31%
		Q78h_dic_MV	0,252	MODERATE RELATION	6,35%
		Q78i_dic_MV	0,218	MODERATE RELATION	4,75%
Results & Effects	Q90a_inv	Q78a_dic_MV	0,049	Small relation	0,24%
		Q78b_dic_MV	0,081	Small relation	0,66%
		Q78c_dic_MV	0,167	MODERATE RELATION	2,79%
		Q78d_dic_MV	0,168	MODERATE RELATION	2,82%
		Q78e_dic_MV	0,150	MODERATE RELATION	2,25%
		Q78f_dic_MV	0,135	MODERATE RELATION	1,82%
		Q78g_dic_MV	0,051	Small relation	0,26%
		Q78h_dic_MV	0,168	MODERATE RELATION	2,82%
		Q78i_dic_MV	0,194	MODERATE RELATION	3,76%
Results & Effects	Q90b_inv	Q78a_dic_MV	0,013	NO ASSOCIATION	0,02%
		Q78b_dic_MV	0,047	Small relation	0,22%
		Q78c_dic_MV	0,138	MODERATE RELATION	1,90%
		Q78d_dic_MV	0,115	Small relation	1,32%
		Q78e_dic_MV	0,124	Small relation	1,54%
		Q78f_dic_MV	0,076	Small relation	0,58%
		Q78g_dic_MV	0,038	Small relation	0,14%
		Q78h_dic_MV	0,102	Small relation	1,04%
		Q78i_dic_MV	0,131	MODERATE RELATION	1,72%
Results & Effects	Q90c_inv	Q78a_dic_MV	0,000	NO ASSOCIATION	0,00%
		Q78b_dic_MV	0,027	Small relation	0,07%
		Q78c_dic_MV	0,042	Small relation	0,18%
		Q78d_dic_MV	0,033	Small relation	0,11%
		Q78e_dic_MV	0,046	Small relation	0,21%
		Q78f_dic_MV	0,024	Small relation	0,06%
		Q78g_dic_MV	0,025	Small relation	0,06%
		Q78h_dic_MV	0,055	Small relation	0,30%
		Q78i_dic_MV	0,050	Small relation	0,25%
Home-work interface	Q47_Rect	Q27_dic_MV	0,010	NO ASSOCIATION	0,01%
		Q36_cat	0,030	Small relation	0,09%
Home-work interface	Q44_Rect	Q27_dic_MV	0,002	NO ASSOCIATION	0,00%
		Q36_cat	0,078	Small relation	0,61%
Home-work interface	Q18a_inv	Q27_dic_MV	0,032	Small relation	0,10%
		Q36_cat	0,036	Small relation	0,13%
Home-work interface	Q18b_inv	Q27_dic_MV	0,023	Small relation	0,05%
		Q36_cat	0,042	Small relation	0,18%
Home-work interface	Q18c_inv	Q27_dic_MV	0,037	Small relation	0,14%
		Q36_cat	0,033	Small relation	0,11%
Home-work interface	Q18d_inv	Q27_dic_MV	0,035	Small relation	0,12%
		Q36_cat	0,059	Small relation	0,35%

Tabla 7 (continuación)

INTRA-GROUP ASSOCIATIONS BETWEEN QUALITATIVE AND SCALE VARIABLES

GROUP	Variables		ETA	Comments	Explained Variance
	Dependent	Independent	value		
Home-work interface	Q100	Q27_dic_MV	0,027	Small relation	0,07%
		Q36_cat	0,044	Small relation	0,19%
Interpersonal relationships at work	Q63a_inv	Q64_aRect	0,000	NO ASSOCIATION	0,00%
		Q64_bRect	0,009	NO ASSOCIATION	0,01%
		Q64_cRect	0,010	NO ASSOCIATION	0,01%
		Q65a_dic_MV	0,082	Small relation	0,67%
		Q65b_dic_MV	0,012	NO ASSOCIATION	0,01%
		Q65c_dic_MV	0,081	Small relation	0,66%
		Q65d_dic_MV	0,022	Small relation	0,05%
Interpersonal relationships at work	Q63b_inv	Q64_aRect	0,012	NO ASSOCIATION	0,01%
		Q64_bRect	0,000	NO ASSOCIATION	0,00%
		Q64_cRect	0,009	NO ASSOCIATION	0,01%
		Q65a_dic_MV	0,096	Small relation	0,92%
		Q65b_dic_MV	0,006	NO ASSOCIATION	0,00%
		Q65c_dic_MV	0,110	Small relation	1,21%
		Q65d_dic_MV	0,036	Small relation	0,13%
Interpersonal relationships at work	Q63c_inv	Q64_aRect	0,007	NO ASSOCIATION	0,00%
		Q64_bRect	0,023	Small relation	0,05%
		Q64_cRect	0,020	Small relation	0,04%
		Q65a_dic_MV	0,047	Small relation	0,22%
		Q65b_dic_MV	0,014	NO ASSOCIATION	0,02%
		Q65c_dic_MV	0,069	Small relation	0,48%
		Q65d_dic_MV	0,000	NO ASSOCIATION	0,00%
Interpersonal relationships at work	Q63d_inv	Q64_aRect	0,004	NO ASSOCIATION	0,00%
		Q64_bRect	0,007	NO ASSOCIATION	0,00%
		Q64_cRect	0,005	NO ASSOCIATION	0,00%
		Q65a_dic_MV	0,060	Small relation	0,36%
		Q65b_dic_MV	0,005	NO ASSOCIATION	0,00%
		Q65c_dic_MV	0,079	Small relation	0,62%
		Q65d_dic_MV	0,017	NO ASSOCIATION	0,03%
Interpersonal relationships at work	Q63e_inv	Q64_aRect	0,006	NO ASSOCIATION	0,00%
		Q64_bRect	0,004	NO ASSOCIATION	0,00%
		Q64_cRect	0,008	NO ASSOCIATION	0,01%
		Q65a_dic_MV	0,074	Small relation	0,55%
		Q65b_dic_MV	0,006	NO ASSOCIATION	0,00%
		Q65c_dic_MV	0,088	Small relation	0,77%
		Q65d_dic_MV	0,025	Small relation	0,06%
Interpersonal relationships at work	Q63f_inv	Q64_aRect	0,035	Small relation	0,12%
		Q64_bRect	0,005	NO ASSOCIATION	0,00%
		Q64_cRect	0,021	Small relation	0,04%
		Q65a_dic_MV	0,132	MODERATE RELATION	1,74%
		Q65b_dic_MV	0,013	NO ASSOCIATION	0,02%
		Q65c_dic_MV	0,136	MODERATE RELATION	1,85%
		Q65d_dic_MV	0,054	Small relation	0,29%
Organizational culture	Q70a_inv	Q15a	0,057	Small relation	0,32%
		Q71a_dic_MV	0,030	Small relation	0,09%
		Q71b_dic_MV	0,016	NO ASSOCIATION	0,03%
		Q71c_dic_MV	0,180	MODERATE RELATION	3,24%

Tabla 7 (continuación)

INTRA-GROUP ASSOCIATIONS BETWEEN QUALITATIVE AND SCALE VARIABLES

GROUP	Variables		ETA	Comments	Explained Variance
	Dependent	Independent	value		
Organizational culture	Q70b_inv	Q15a	0,044	Small relation	0,19%
		Q71a_dic_MV	0,015	NO ASSOCIATION	0,02%
		Q71b_dic_MV	0,023	Small relation	0,05%
		Q71c_dic_MV	0,148	MODERATE RELATION	2,19%
Organizational culture	Q70c_inv	Q15a	0,071	Small relation	0,50%
		Q71a_dic_MV	0,062	Small relation	0,38%
		Q71b_dic_MV	0,014	NO ASSOCIATION	0,02%
		Q71c_dic_MV	0,142	MODERATE RELATION	2,02%
Organizational culture	Q70d_inv	Q15a	0,079	Small relation	0,62%
		Q71a_dic_MV	0,059	Small relation	0,35%
		Q71b_dic_MV	0,010	NO ASSOCIATION	0,01%
		Q71c_dic_MV	0,127	Small relation	1,61%
Organizational culture	Q70e_inv	Q15a	0,012	NO ASSOCIATION	0,01%
		Q71a_dic_MV	0,055	Small relation	0,30%
		Q71b_dic_MV	0,080	Small relation	0,64%
		Q71c_dic_MV	0,147	MODERATE RELATION	2,16%
Organizational culture	Q70f_inv	Q15a	0,125	Small relation	1,56%
		Q71a_dic_MV	0,121	Small relation	1,46%
		Q71b_dic_MV	0,068	Small relation	0,46%
		Q71c_dic_MV	0,112	Small relation	1,25%
Organizational culture	Q61l_inv	Q15a	0,023	Small relation	0,05%
		Q71a_dic_MV	0,017	NO ASSOCIATION	0,03%
		Q71b_dic_MV	0,052	Small relation	0,27%
		Q71c_dic_MV	0,159	MODERATE RELATION	2,53%
Organizational culture	Q61n_inv	Q15a	0,008	NO ASSOCIATION	0,01%
		Q71a_dic_MV	0,040	Small relation	0,16%
		Q71b_dic_MV	0,093	Small relation	0,86%
		Q71c_dic_MV	0,192	MODERATE RELATION	3,69%
Organizational culture	Q89d_inv	Q15a	0,045	Small relation	0,20%
		Q71a_dic_MV	0,085	Small relation	0,72%
		Q71b_dic_MV	0,102	Small relation	1,04%
		Q71c_dic_MV	0,145	MODERATE RELATION	2,10%
Organizational culture	Q89e_inv	Q15a	0,035	Small relation	0,12%
		Q71a_dic_MV	0,003	NO ASSOCIATION	0,00%
		Q71b_dic_MV	0,055	Small relation	0,30%
		Q71c_dic_MV	0,205	MODERATE RELATION	4,20%

Tabla 7 (continuación)

INTRA-GROUP ASSOCIATIONS BETWEEN QUALITATIVE AND SCALE VARIABLES

GROUP	Variables		ETA	Comments	Explained Variance
	Dependent	Independent	value		
Environment & equipment	Q29a_inv_ReplaceMD_1	Q31_dic_MV	0,349	STRONG RELATION	12,18%
		Q72a_dic_MV	0,024	Small relation	0,06%
		Q72b_dic_MV	0,028	Small relation	0,08%
		Q72c_dic_MV	0,023	Small relation	0,05%
		Q72d_dic_MV	0,003	NO ASSOCIATION	0,00%
		Q72e_dic_MV	0,022	Small relation	0,05%
		Q72f_dic_MV	0,023	Small relation	0,05%
		Q72g_dic_MV	0,007	NO ASSOCIATION	0,00%
		Q73_dic_MV	0,231	MODERATE RELATION	5,34%
		Q80a_dic_MV	0,001	NO ASSOCIATION	0,00%
		Q80b_dic_MV	0,008	NO ASSOCIATION	0,01%
		Q80c_dic_MV	0,002	NO ASSOCIATION	0,00%
		Q80d_dic_MV	0,012	NO ASSOCIATION	0,01%
		Q81a_dic_MV	0,020	Small relation	0,04%
		Q81b_dic_MV	0,007	NO ASSOCIATION	0,00%
Q81c_dic_MV	0,013	NO ASSOCIATION	0,02%		
Environment & equipment	Q29b_inv_ReplaceMD_1	Q31_dic_MV	0,298	STRONG RELATION	8,88%
		Q72a_dic_MV	0,050	Small relation	0,25%
		Q72b_dic_MV	0,048	Small relation	0,23%
		Q72c_dic_MV	0,042	Small relation	0,18%
		Q72d_dic_MV	0,025	Small relation	0,06%
		Q72e_dic_MV	0,038	Small relation	0,14%
		Q72f_dic_MV	0,036	Small relation	0,13%
		Q72g_dic_MV	0,022	Small relation	0,05%
		Q73_dic_MV	0,262	STRONG RELATION	6,86%
		Q80a_dic_MV	0,076	Small relation	0,58%
		Q80b_dic_MV	0,026	Small relation	0,07%
		Q80c_dic_MV	0,055	Small relation	0,30%
		Q80d_dic_MV	0,073	Small relation	0,53%
		Q81a_dic_MV	0,034	Small relation	0,12%
		Q81b_dic_MV	0,015	NO ASSOCIATION	0,02%
Q81c_dic_MV	0,067	Small relation	0,45%		
Environment & equipment	Q29c_inv_ReplaceMD_1	Q31_dic_MV	0,285	STRONG RELATION	8,12%
		Q72a_dic_MV	0,048	Small relation	0,23%
		Q72b_dic_MV	0,040	Small relation	0,16%
		Q72c_dic_MV	0,043	Small relation	0,18%
		Q72d_dic_MV	0,035	Small relation	0,12%
		Q72e_dic_MV	0,043	Small relation	0,18%
		Q72f_dic_MV	0,038	Small relation	0,14%
		Q72g_dic_MV	0,031	Small relation	0,10%
		Q73_dic_MV	0,266	STRONG RELATION	7,08%
		Q80a_dic_MV	0,063	Small relation	0,40%
		Q80b_dic_MV	0,032	Small relation	0,10%
		Q80c_dic_MV	0,059	Small relation	0,35%
		Q80d_dic_MV	0,076	Small relation	0,58%
		Q81a_dic_MV	0,038	Small relation	0,14%
		Q81b_dic_MV	0,027	Small relation	0,07%
Q81c_dic_MV	0,063	Small relation	0,40%		

Tabla 7 (continuación)

INTRA-GROUP ASSOCIATIONS BETWEEN QUALITATIVE AND SCALE VARIABLES

GROUP	Variables		ETA	Comments	Explained Variance
	Dependent	Independent	value		
Environment & equipment	Q29d_inv_ReplaceMD_1	Q31_dic_MV	0,277	STRONG RELATION	7,67%
		Q72a_dic_MV	0,051	Small relation	0,26%
		Q72b_dic_MV	0,044	Small relation	0,19%
		Q72c_dic_MV	0,045	Small relation	0,20%
		Q72d_dic_MV	0,036	Small relation	0,13%
		Q72e_dic_MV	0,038	Small relation	0,14%
		Q72f_dic_MV	0,035	Small relation	0,12%
		Q72g_dic_MV	0,017	NO ASSOCIATION	0,03%
		Q73_dic_MV	0,240	MODERATE RELATION	5,76%
		Q80a_dic_MV	0,068	Small relation	0,46%
		Q80b_dic_MV	0,024	Small relation	0,06%
		Q80c_dic_MV	0,068	Small relation	0,46%
		Q80d_dic_MV	0,065	Small relation	0,42%
		Q81a_dic_MV	0,038	Small relation	0,14%
		Q81b_dic_MV	0,012	NO ASSOCIATION	0,01%
Q81c_dic_MV	0,066	Small relation	0,44%		
Environment & equipment	Q29e_inv_ReplaceMD_1	Q31_dic_MV	0,332	STRONG RELATION	11,02%
		Q72a_dic_MV	0,030	Small relation	0,09%
		Q72b_dic_MV	0,042	Small relation	0,18%
		Q72c_dic_MV	0,043	Small relation	0,18%
		Q72d_dic_MV	0,013	NO ASSOCIATION	0,02%
		Q72e_dic_MV	0,035	Small relation	0,12%
		Q72f_dic_MV	0,027	Small relation	0,07%
		Q72g_dic_MV	0,017	NO ASSOCIATION	0,03%
		Q73_dic_MV	0,276	STRONG RELATION	7,62%
		Q80a_dic_MV	0,025	Small relation	0,06%
		Q80b_dic_MV	0,002	NO ASSOCIATION	0,00%
		Q80c_dic_MV	0,022	Small relation	0,05%
		Q80d_dic_MV	0,036	Small relation	0,13%
		Q81a_dic_MV	0,002	NO ASSOCIATION	0,00%
		Q81b_dic_MV	0,001	NO ASSOCIATION	0,00%
Q81c_dic_MV	0,037	Small relation	0,14%		
Environment & equipment	Q29f_inv_LD	Q31_dic_MV	0,299	STRONG RELATION	8,94%
		Q72a_dic_MV	0,042	Small relation	0,18%
		Q72b_dic_MV	0,052	Small relation	0,27%
		Q72c_dic_MV	0,051	Small relation	0,26%
		Q72d_dic_MV	0,028	Small relation	0,08%
		Q72e_dic_MV	0,046	Small relation	0,21%
		Q72f_dic_MV	0,034	Small relation	0,12%
		Q72g_dic_MV	0,021	Small relation	0,04%
		Q73_dic_MV	0,223	MODERATE RELATION	4,97%
		Q80a_dic_MV	0,025	Small relation	0,06%
		Q80b_dic_MV	0,013	NO ASSOCIATION	0,02%
		Q80c_dic_MV	0,017	NO ASSOCIATION	0,03%
		Q80d_dic_MV	0,039	Small relation	0,15%
		Q81a_dic_MV	0,008	NO ASSOCIATION	0,01%
		Q81b_dic_MV	0,015	NO ASSOCIATION	0,02%
Q81c_dic_MV	0,040	Small relation	0,16%		

Tabla 7 (continuación)

INTRA-GROUP ASSOCIATIONS BETWEEN QUALITATIVE AND SCALE VARIABLES

GROUP	Variables		ETA	Comments	Explained Variance
	Dependent	Independent	value		
Environment & equipment	Q29g_inv_LD	Q31_dic_MV	0,359	STRONG RELATION	12,89%
		Q72a_dic_MV	0,039	Small relation	0,15%
		Q72b_dic_MV	0,046	Small relation	0,21%
		Q72c_dic_MV	0,049	Small relation	0,24%
		Q72d_dic_MV	0,022	Small relation	0,05%
		Q72e_dic_MV	0,037	Small relation	0,14%
		Q72f_dic_MV	0,034	Small relation	0,12%
		Q72g_dic_MV	0,025	Small relation	0,06%
		Q73_dic_MV	0,229	MODERATE RELATION	5,24%
		Q80a_dic_MV	0,044	Small relation	0,19%
		Q80b_dic_MV	0,030	Small relation	0,09%
		Q80c_dic_MV	0,045	Small relation	0,20%
		Q80d_dic_MV	0,059	Small relation	0,35%
		Q81a_dic_MV	0,039	Small relation	0,15%
		Q81b_dic_MV	0,034	Small relation	0,12%
		Q81c_dic_MV	0,055	Small relation	0,30%
Environment & equipment	Q29h_inv_LD	Q31_dic_MV	0,141	MODERATE RELATION	1,99%
		Q72a_dic_MV	0,044	Small relation	0,19%
		Q72b_dic_MV	0,036	Small relation	0,13%
		Q72c_dic_MV	0,038	Small relation	0,14%
		Q72d_dic_MV	0,030	Small relation	0,09%
		Q72e_dic_MV	0,042	Small relation	0,18%
		Q72f_dic_MV	0,033	Small relation	0,11%
		Q72g_dic_MV	0,037	Small relation	0,14%
		Q73_dic_MV	0,138	MODERATE RELATION	1,90%
		Q80a_dic_MV	0,073	Small relation	0,53%
		Q80b_dic_MV	0,063	Small relation	0,40%
		Q80c_dic_MV	0,064	Small relation	0,41%
		Q80d_dic_MV	0,056	Small relation	0,31%
		Q81a_dic_MV	0,057	Small relation	0,32%
		Q81b_dic_MV	0,062	Small relation	0,38%
		Q81c_dic_MV	0,052	Small relation	0,27%
Environment & equipment	Q29i_inv_LD	Q31_dic_MV	0,306	STRONG RELATION	9,36%
		Q72a_dic_MV	0,042	Small relation	0,18%
		Q72b_dic_MV	0,054	Small relation	0,29%
		Q72c_dic_MV	0,054	Small relation	0,29%
		Q72d_dic_MV	0,037	Small relation	0,14%
		Q72e_dic_MV	0,043	Small relation	0,18%
		Q72f_dic_MV	0,031	Small relation	0,10%
		Q72g_dic_MV	0,023	Small relation	0,05%
		Q73_dic_MV	0,217	MODERATE RELATION	4,71%
		Q80a_dic_MV	0,115	Small relation	1,32%
		Q80b_dic_MV	0,079	Small relation	0,62%
		Q80c_dic_MV	0,104	Small relation	1,08%
		Q80d_dic_MV	0,086	Small relation	0,74%
		Q81a_dic_MV	0,158	MODERATE RELATION	2,50%
		Q81b_dic_MV	0,070	Small relation	0,49%
		Q81c_dic_MV	0,086	Small relation	0,74%

Tabla 7 (continuación)

INTRA-GROUP ASSOCIATIONS BETWEEN QUALITATIVE AND SCALE VARIABLES

GROUP	Variables		ETA	Comments	Explained Variance
	Dependent	Independent	value		
Environment & equipment	Q30d_inv_LD	Q31_dic_MV	0,321	STRONG RELATION	10,30%
		Q72a_dic_MV	0,005	NO ASSOCIATION	0,00%
		Q72b_dic_MV	0,023	Small relation	0,05%
		Q72c_dic_MV	0,022	Small relation	0,05%
		Q72d_dic_MV	0,026	Small relation	0,07%
		Q72e_dic_MV	0,008	NO ASSOCIATION	0,01%
		Q72f_dic_MV	0,008	NO ASSOCIATION	0,01%
		Q72g_dic_MV	0,004	NO ASSOCIATION	0,00%
		Q73_dic_MV	0,115	Small relation	1,32%
		Q80a_dic_MV	0,005	NO ASSOCIATION	0,00%
		Q80b_dic_MV	0,017	NO ASSOCIATION	0,03%
		Q80c_dic_MV	0,015	NO ASSOCIATION	0,02%
		Q80d_dic_MV	0,004	NO ASSOCIATION	0,00%
		Q81a_dic_MV	0,036	Small relation	0,13%
		Q81b_dic_MV	0,013	NO ASSOCIATION	0,02%
		Q81c_dic_MV	0,008	NO ASSOCIATION	0,01%
Environment & equipment	Q30f_inv_ReplaceMD_1	Q31_dic_MV	0,139	MODERATE RELATION	1,93%
		Q72a_dic_MV	0,020	Small relation	0,04%
		Q72b_dic_MV	0,016	NO ASSOCIATION	0,03%
		Q72c_dic_MV	0,011	NO ASSOCIATION	0,01%
		Q72d_dic_MV	0,029	Small relation	0,08%
		Q72e_dic_MV	0,013	NO ASSOCIATION	0,02%
		Q72f_dic_MV	0,008	NO ASSOCIATION	0,01%
		Q72g_dic_MV	0,012	NO ASSOCIATION	0,01%
		Q73_dic_MV	0,002	NO ASSOCIATION	0,00%
		Q80a_dic_MV	0,141	MODERATE RELATION	1,99%
		Q80b_dic_MV	0,075	Small relation	0,56%
		Q80c_dic_MV	0,111	Small relation	1,23%
		Q80d_dic_MV	0,080	Small relation	0,64%
		Q81a_dic_MV	0,096	Small relation	0,92%
		Q81b_dic_MV	0,057	Small relation	0,32%
		Q81c_dic_MV	0,062	Small relation	0,38%
Environment & equipment	Q30g_inv_ReplaceMD_1	Q31_dic_MV	0,073	Small relation	0,53%
		Q72a_dic_MV	0,047	Small relation	0,22%
		Q72b_dic_MV	0,041	Small relation	0,17%
		Q72c_dic_MV	0,040	Small relation	0,16%
		Q72d_dic_MV	0,041	Small relation	0,17%
		Q72e_dic_MV	0,027	Small relation	0,07%
		Q72f_dic_MV	0,020	Small relation	0,04%
		Q72g_dic_MV	0,026	Small relation	0,07%
		Q73_dic_MV	0,083	Small relation	0,69%
		Q80a_dic_MV	0,180	MODERATE RELATION	3,24%
		Q80b_dic_MV	0,085	Small relation	0,72%
		Q80c_dic_MV	0,172	MODERATE RELATION	2,96%
		Q80d_dic_MV	0,135	MODERATE RELATION	1,82%
		Q81a_dic_MV	0,129	Small relation	1,66%
		Q81b_dic_MV	0,067	Small relation	0,45%
		Q81c_dic_MV	0,107	Small relation	1,14%

Tabla 7 (continuación)

INTRA-GROUP ASSOCIATIONS BETWEEN QUALITATIVE AND SCALE VARIABLES

GROUP	Variables		ETA	Comments	Explained Variance
	Dependent	Independent	value		
Environment & equipment	Q30h_inv_ReplaceMD_1	Q31_dic_MV	0,023	Small relation	0,05%
		Q72a_dic_MV	0,092	Small relation	0,85%
		Q72b_dic_MV	0,056	Small relation	0,31%
		Q72c_dic_MV	0,058	Small relation	0,34%
		Q72d_dic_MV	0,074	Small relation	0,55%
		Q72e_dic_MV	0,046	Small relation	0,21%
		Q72f_dic_MV	0,047	Small relation	0,22%
		Q72g_dic_MV	0,034	Small relation	0,12%
		Q73_dic_MV	0,215	MODERATE RELATION	4,62%
		Q80a_dic_MV	0,232	MODERATE RELATION	5,38%
		Q80b_dic_MV	0,094	Small relation	0,88%
		Q80c_dic_MV	0,218	MODERATE RELATION	4,75%
		Q80d_dic_MV	0,207	MODERATE RELATION	4,28%
		Q81a_dic_MV	0,138	MODERATE RELATION	1,90%
		Q81b_dic_MV	0,077	Small relation	0,59%
		Q81c_dic_MV	0,175	MODERATE RELATION	3,06%
Environment & equipment	Q30i_inv_ReplaceMD_1	Q31_dic_MV	0,281	STRONG RELATION	7,90%
		Q72a_dic_MV	0,011	NO ASSOCIATION	0,01%
		Q72b_dic_MV	0,012	NO ASSOCIATION	0,01%
		Q72c_dic_MV	0,012	NO ASSOCIATION	0,01%
		Q72d_dic_MV	0,041	Small relation	0,17%
		Q72e_dic_MV	0,000	NO ASSOCIATION	0,00%
		Q72f_dic_MV	0,011	NO ASSOCIATION	0,01%
		Q72g_dic_MV	0,000	NO ASSOCIATION	0,00%
		Q73_dic_MV	0,120	Small relation	1,44%
		Q80a_dic_MV	0,033	Small relation	0,11%
		Q80b_dic_MV	0,007	NO ASSOCIATION	0,00%
		Q80c_dic_MV	0,044	Small relation	0,19%
		Q80d_dic_MV	0,024	Small relation	0,06%
		Q81a_dic_MV	0,003	NO ASSOCIATION	0,00%
		Q81b_dic_MV	0,005	NO ASSOCIATION	0,00%
		Q81c_dic_MV	0,031	Small relation	0,10%
Environment & equipment	Q33_rect_inv	Q31_dic_MV	0,091	Small relation	0,83%
		Q72a_dic_MV	0,049	Small relation	0,24%
		Q72b_dic_MV	0,046	Small relation	0,21%
		Q72c_dic_MV	0,035	Small relation	0,12%
		Q72d_dic_MV	0,035	Small relation	0,12%
		Q72e_dic_MV	0,029	Small relation	0,08%
		Q72f_dic_MV	0,018	NO ASSOCIATION	0,03%
		Q72g_dic_MV	0,008	NO ASSOCIATION	0,01%
		Q73_dic_MV	0,069	Small relation	0,48%
		Q80a_dic_MV	0,056	Small relation	0,31%
		Q80b_dic_MV	0,030	Small relation	0,09%
		Q80c_dic_MV	0,039	Small relation	0,15%
		Q80d_dic_MV	0,085	Small relation	0,72%
		Q81a_dic_MV	0,013	NO ASSOCIATION	0,02%
		Q81b_dic_MV	0,022	Small relation	0,05%
		Q81c_dic_MV	0,079	Small relation	0,62%

Tabla 7 (continuación)

INTRA-GROUP ASSOCIATIONS BETWEEN QUALITATIVE AND SCALE VARIABLES

GROUP	Variables		ETA	Comments	Explained Variance
	Dependent	Independent	value		
Environment & equipment	Q61a_inv	Q31_dic_MV	0,039	Small relation	0,15%
		Q72a_dic_MV	0,054	Small relation	0,29%
		Q72b_dic_MV	0,049	Small relation	0,24%
		Q72c_dic_MV	0,048	Small relation	0,23%
		Q72d_dic_MV	0,044	Small relation	0,19%
		Q72e_dic_MV	0,034	Small relation	0,12%
		Q72f_dic_MV	0,044	Small relation	0,19%
		Q72g_dic_MV	0,016	NO ASSOCIATION	0,03%
		Q73_dic_MV	0,040	Small relation	0,16%
		Q80a_dic_MV	0,069	Small relation	0,48%
		Q80b_dic_MV	0,027	Small relation	0,07%
		Q80c_dic_MV	0,041	Small relation	0,17%
		Q80d_dic_MV	0,093	Small relation	0,86%
		Q81a_dic_MV	0,007	NO ASSOCIATION	0,00%
		Q81b_dic_MV	0,015	NO ASSOCIATION	0,02%
		Q81c_dic_MV	0,094	Small relation	0,88%
Environment & equipment	Q61b_inv	Q31_dic_MV	0,021	Small relation	0,04%
		Q72a_dic_MV	0,073	Small relation	0,53%
		Q72b_dic_MV	0,054	Small relation	0,29%
		Q72c_dic_MV	0,055	Small relation	0,30%
		Q72d_dic_MV	0,059	Small relation	0,35%
		Q72e_dic_MV	0,030	Small relation	0,09%
		Q72f_dic_MV	0,042	Small relation	0,18%
		Q72g_dic_MV	0,021	Small relation	0,04%
		Q73_dic_MV	0,120	Small relation	1,44%
		Q80a_dic_MV	0,115	Small relation	1,32%
		Q80b_dic_MV	0,036	Small relation	0,13%
		Q80c_dic_MV	0,077	Small relation	0,59%
		Q80d_dic_MV	0,147	MODERATE RELATION	2,16%
		Q81a_dic_MV	0,024	Small relation	0,06%
		Q81b_dic_MV	0,034	Small relation	0,12%
		Q81c_dic_MV	0,148	MODERATE RELATION	2,19%
Control	Q43_inv	Q42_dic1	0,668	STRONG RELATION	44,62%
		Q42_dic2	0,067	Small relation	0,45%
		Q42_dic3	0,674	STRONG RELATION	45,43%
		Q42_dic4	0,318	STRONG RELATION	10,11%
		Q54a_dic_MV	0,165	MODERATE RELATION	2,72%
		Q54b_dic_MV	0,140	MODERATE RELATION	1,96%
		Q54c_dic_MV	0,097	Small relation	0,94%
		Q50a_dic_MV	0,002	NO ASSOCIATION	0,00%
		Q50b_dic_MV	0,090	Small relation	0,81%
		Q50c_dic_MV	0,046	Small relation	0,21%
		Q50d_dic_MV	0,053	Small relation	0,28%
		Q50e_dic_MV	0,096	Small relation	0,92%
		Q52_dic1	0,126	Small relation	1,59%
		Q52_dic2	0,131	MODERATE RELATION	1,72%
		Q52_dic3	0,022	Small relation	0,05%
		Q58_dic_MV	0,051	Small relation	0,26%

Tabla 7 (continuación)

INTRA-GROUP ASSOCIATIONS BETWEEN QUALITATIVE AND SCALE VARIABLES

GROUP	Variables		ETA	Comments	Explained Variance
	Dependent	Independent	value		
Control	Q51_inv	Q42_dic1	0,160	MODERATE RELATION	2,56%
		Q42_dic2	0,027	Small relation	0,07%
		Q42_dic3	0,155	MODERATE RELATION	2,40%
		Q42_dic4	0,031	Small relation	0,10%
		Q54a_dic_MV	0,182	MODERATE RELATION	3,31%
		Q54b_dic_MV	0,135	MODERATE RELATION	1,82%
		Q54c_dic_MV	0,072	Small relation	0,52%
		Q50a_dic_MV	0,168	MODERATE RELATION	2,82%
		Q50b_dic_MV	0,183	MODERATE RELATION	3,35%
		Q50c_dic_MV	0,097	Small relation	0,94%
		Q50d_dic_MV	0,014	NO ASSOCIATION	0,02%
		Q50e_dic_MV	0,057	Small relation	0,32%
		Q52_dic1	0,429	STRONG RELATION	18,40%
		Q52_dic2	0,450	STRONG RELATION	20,25%
		Q52_dic3	0,084	Small relation	0,71%
		Q58_dic_MV	0,169	MODERATE RELATION	2,86%
Control	Q61c_inv	Q42_dic1	0,158	MODERATE RELATION	2,50%
		Q42_dic2	0,021	Small relation	0,04%
		Q42_dic3	0,129	Small relation	1,66%
		Q42_dic4	0,084	Small relation	0,71%
		Q54a_dic_MV	0,237	MODERATE RELATION	5,62%
		Q54b_dic_MV	0,233	MODERATE RELATION	5,43%
		Q54c_dic_MV	0,205	MODERATE RELATION	4,20%
		Q50a_dic_MV	0,026	Small relation	0,07%
		Q50b_dic_MV	0,052	Small relation	0,27%
		Q50c_dic_MV	0,003	NO ASSOCIATION	0,00%
		Q50d_dic_MV	0,064	Small relation	0,41%
		Q50e_dic_MV	0,057	Small relation	0,32%
		Q52_dic1	0,035	Small relation	0,12%
		Q52_dic2	0,003	NO ASSOCIATION	0,00%
		Q52_dic3	0,074	Small relation	0,55%
		Q58_dic_MV	0,148	MODERATE RELATION	2,19%
Control	Q61d_inv	Q42_dic1	0,184	MODERATE RELATION	3,39%
		Q42_dic2	0,029	Small relation	0,08%
		Q42_dic3	0,145	MODERATE RELATION	2,10%
		Q42_dic4	0,101	Small relation	1,02%
		Q54a_dic_MV	0,269	STRONG RELATION	7,24%
		Q54b_dic_MV	0,271	STRONG RELATION	7,34%
		Q54c_dic_MV	0,207	MODERATE RELATION	4,28%
		Q50a_dic_MV	0,044	Small relation	0,19%
		Q50b_dic_MV	0,102	Small relation	1,04%
		Q50c_dic_MV	0,045	Small relation	0,20%
		Q50d_dic_MV	0,054	Small relation	0,29%
		Q50e_dic_MV	0,066	Small relation	0,44%
		Q52_dic1	0,042	Small relation	0,18%
		Q52_dic2	0,079	Small relation	0,62%
		Q52_dic3	0,078	Small relation	0,61%
		Q58_dic_MV	0,186	MODERATE RELATION	3,46%

Tabla 7 (continuación)

INTRA-GROUP ASSOCIATIONS BETWEEN QUALITATIVE AND SCALE VARIABLES

GROUP	Variables		ETA	Comments	Explained Variance
	Dependent	Independent	value		
Control	Q61e_inv	Q42_dic1	0,157	MODERATE RELATION	2,46%
		Q42_dic2	0,035	Small relation	0,12%
		Q42_dic3	0,094	Small relation	0,88%
		Q42_dic4	0,126	Small relation	1,59%
		Q54a_dic_MV	0,195	MODERATE RELATION	3,80%
		Q54b_dic_MV	0,189	MODERATE RELATION	3,57%
		Q54c_dic_MV	0,149	MODERATE RELATION	2,22%
		Q50a_dic_MV	0,080	Small relation	0,64%
		Q50b_dic_MV	0,038	Small relation	0,14%
		Q50c_dic_MV	0,060	Small relation	0,36%
		Q50d_dic_MV	0,020	Small relation	0,04%
		Q50e_dic_MV	0,057	Small relation	0,32%
		Q52_dic1	0,005	NO ASSOCIATION	0,00%
		Q52_dic2	0,035	Small relation	0,12%
		Q52_dic3	0,061	Small relation	0,37%
		Q58_dic_MV	0,117	Small relation	1,37%
Control	Q61f_inv	Q42_dic1	0,280	STRONG RELATION	7,84%
		Q42_dic2	0,004	NO ASSOCIATION	0,00%
		Q42_dic3	0,241	MODERATE RELATION	5,81%
		Q42_dic4	0,166	MODERATE RELATION	2,76%
		Q54a_dic_MV	0,320	STRONG RELATION	10,24%
		Q54b_dic_MV	0,242	MODERATE RELATION	5,86%
		Q54c_dic_MV	0,259	MODERATE RELATION	6,71%
		Q50a_dic_MV	0,041	Small relation	0,17%
		Q50b_dic_MV	0,025	Small relation	0,06%
		Q50c_dic_MV	0,038	Small relation	0,14%
		Q50d_dic_MV	0,104	Small relation	1,08%
		Q50e_dic_MV	0,105	Small relation	1,10%
		Q52_dic1	0,044	Small relation	0,19%
		Q52_dic2	0,024	Small relation	0,06%
		Q52_dic3	0,035	Small relation	0,12%
		Q58_dic_MV	0,006	NO ASSOCIATION	0,00%
Workload & workspace	Q40_inv	Q24_cat	0,146	MODERATE RELATION	2,13%
		Q26_cat	0,169	MODERATE RELATION	2,86%
		Q37a_dic	0,221	MODERATE RELATION	4,88%
		Q37b_dic	0,243	MODERATE RELATION	5,90%
		Q37c_dic	0,263	STRONG RELATION	6,92%
		Q37d_dic	0,190	MODERATE RELATION	3,61%
		Q38_dic_inv	0,193	MODERATE RELATION	3,72%
		Q39a_dic	0,184	MODERATE RELATION	3,39%
		Q39b_dic	0,245	MODERATE RELATION	6,00%
		Q39c_dic	0,234	MODERATE RELATION	5,48%
		Q39d_dic	0,177	MODERATE RELATION	3,13%
		Q39e_dic	0,175	MODERATE RELATION	3,06%
		Workload & workspace	Q46_inv	Q24_cat	0,166
Q26_cat	0,070			Small relation	0,49%
Q37a_dic	0,092			Small relation	0,85%
Q37b_dic	0,128			Small relation	1,64%
Q37c_dic	0,085			Small relation	0,72%
Q37d_dic	0,317			STRONG RELATION	10,05%
Q38_dic_inv	0,209			MODERATE RELATION	4,37%
Q39a_dic	0,278			STRONG RELATION	7,73%
Q39b_dic	0,083			Small relation	0,69%
Q39c_dic	0,227			MODERATE RELATION	5,15%
Q39d_dic	0,247			MODERATE RELATION	6,10%
Q39e_dic	0,082			Small relation	0,67%

Tabla 7 (continuación)

INTRA-GROUP ASSOCIATIONS BETWEEN QUALITATIVE AND SCALE VARIABLES

GROUP	Variables		ETA	Comments	Explained Variance
	Dependent	Independent	value		
Job content	Q49a_inv	Q23_cat	0,030	Small relation	0,09%
		Q48a_dic_MV	0,224	MODERATE RELATION	5,02%
		Q48b_dic_MV	0,237	MODERATE RELATION	5,62%
		Q53a_dic_MV	0,178	MODERATE RELATION	3,17%
		Q53b_dic_MV	0,081	Small relation	0,66%
		Q53c_dic_MV	0,053	Small relation	0,28%
		Q53d_dic_MV	0,162	MODERATE RELATION	2,62%
		Q53e_dic_MV	0,109	Small relation	1,19%
		Q53f_dic_MV	0,043	Small relation	0,18%
Job content	Q49b_inv	Q23_cat	0,086	Small relation	0,74%
		Q48a_dic_MV	0,155	MODERATE RELATION	2,40%
		Q48b_dic_MV	0,168	MODERATE RELATION	2,82%
		Q53a_dic_MV	0,207	MODERATE RELATION	4,28%
		Q53b_dic_MV	0,116	Small relation	1,35%
		Q53c_dic_MV	0,101	Small relation	1,02%
		Q53d_dic_MV	0,131	MODERATE RELATION	1,72%
		Q53e_dic_MV	0,191	MODERATE RELATION	3,65%
		Q53f_dic_MV	0,109	Small relation	1,19%
Job content	Q61h_inv	Q23_cat	0,045	Small relation	0,20%
		Q48a_dic_MV	0,031	Small relation	0,10%
		Q48b_dic_MV	0,031	Small relation	0,10%
		Q53a_dic_MV	0,062	Small relation	0,38%
		Q53b_dic_MV	0,097	Small relation	0,94%
		Q53c_dic_MV	0,091	Small relation	0,83%
		Q53d_dic_MV	0,105	Small relation	1,10%
		Q53e_dic_MV	0,059	Small relation	0,35%
		Q53f_dic_MV	0,135	MODERATE RELATION	1,82%
Job content	Q61i_inv	Q23_cat	0,170	MODERATE RELATION	2,89%
		Q48a_dic_MV	0,080	Small relation	0,64%
		Q48b_dic_MV	0,085	Small relation	0,72%
		Q53a_dic_MV	0,051	Small relation	0,26%
		Q53b_dic_MV	0,202	MODERATE RELATION	4,08%
		Q53c_dic_MV	0,247	MODERATE RELATION	6,10%
		Q53d_dic_MV	0,152	MODERATE RELATION	2,31%
		Q53e_dic_MV	0,196	MODERATE RELATION	3,84%
		Q53f_dic_MV	0,290	STRONG RELATION	8,41%
Job content	Q61j_inv	Q23_cat	0,057	Small relation	0,32%
		Q48a_dic_MV	0,055	Small relation	0,30%
		Q48b_dic_MV	0,045	Small relation	0,20%
		Q53a_dic_MV	0,072	Small relation	0,52%
		Q53b_dic_MV	0,105	Small relation	1,10%
		Q53c_dic_MV	0,109	Small relation	1,19%
		Q53d_dic_MV	0,128	Small relation	1,64%
		Q53e_dic_MV	0,101	Small relation	1,02%
		Q53f_dic_MV	0,168	MODERATE RELATION	2,82%
	Q55_dic_MV	0,030	Small relation	0,09%	

Tabla 7 (continuación)

INTRA-GROUP ASSOCIATIONS BETWEEN QUALITATIVE AND SCALE VARIABLES

GROUP	Variables		ETA	Comments	Explained Variance
	Dependent	Independent	value		
Job content	Q61k_inv	Q23_cat	0,028	Small relation	0,08%
		Q48a_dic_MV	0,018	NO ASSOCIATION	0,03%
		Q48b_dic_MV	0,003	NO ASSOCIATION	0,00%
		Q53a_dic_MV	0,048	Small relation	0,23%
		Q53b_dic_MV	0,027	Small relation	0,07%
		Q53c_dic_MV	0,064	Small relation	0,41%
		Q53d_dic_MV	0,027	Small relation	0,07%
		Q53e_dic_MV	0,004	NO ASSOCIATION	0,00%
		Q53f_dic_MV	0,055	Small relation	0,30%
		Q55_dic_MV	0,036	Small relation	0,13%

Tabla 8. Variables consideradas relevantes (variancia explicada $\geq 1\%$), según grupo teórico

Variable Name	Measure			Variable description	Group
	Nominal	Ordinal	Scale		
Total variables used	61	6	75		
Country	x			Country	Segmentation-model control
Q2a		x		Gender	Segmentation-model control
Q2b_cat		x		Age	Segmentation-model control
Q2d_resumen	x			Complete/partial day work	Segmentation-model control
Q11_a	x			Work contract type 1	Segmentation-model control
Q11_b	x			Work contract type 2	Segmentation-model control
Q11_c	x			Work contract type 3	Segmentation-model control
Q14_a	x			Private sector	Segmentation-model control
Q14_b	x			Public sector	Segmentation-model control
Q15a	x			Number of working centers	Segmentation-model control
Q16b		x		Amount of workers	Segmentation-model control
Q42_dic1	x			Working time schedule fixed by company, no changes	Control
Q42_dic3	x			Working time schedule limitedly adapted/flexible	Control
Q42_dic4	x			Working time schedule entirely chosen by each own	Control
Q43_inv		x		Working time schedule changings	Control
Q50a_dic_MV	x			Pace of work depends on other workers	Control
Q50b_dic_MV	x			Pace of work depends on third people demands	Control
Q50d_dic_MV	x			Pace of work depends on speed of machines and product drives	Control
Q50e_dic_MV	x			Pace of work depends on hierarchical control	Control
Q51_inv		x		Interrupting one task to do another	Control
Q52_dic1	x			Task interruptions cut the pace of work	Control
Q52_dic2	x			Task interruptions have no consequences	Control
Q54a_dic_MV	x			Possibility to choose or change - the sequence of own tasks	Control
Q54b_dic_MV	x			Possibility to choose or change - task methods	Control
Q54c_dic_MV	x			Possibility to choose or change - speed or pace of work	Control
Q58_dic_MV	x			Working within a team with common tasks and ability to plan the work	Control
Q61c_inv		x		Consult me before defining work targets	Control
Q61d_inv		x		Involved in improving the work organization or work processes or of the whole company	Control
Q61e_inv		x		Can give opinion about electing my co-workers	Control
Q61f_inv		x		Can make a pause whenever you want to	Control
Q29a_inv_ReplaceMD_1		x		Working conditions - Vibrations	Environment & equipment
Q29b_inv_ReplaceMD_1		x		Working conditions - Noise	Environment & equipment
Q29c_inv_ReplaceMD_1		x		Working conditions - High temperatures	Environment & equipment
Q29d_inv_ReplaceMD_1		x		Working conditions - Low temperatures	Environment & equipment
Q29e_inv_ReplaceMD_1		x		Working conditions - Smoke	Environment & equipment
Q29f_inv_LD		x		Working conditions - Vapors	Environment & equipment
Q29g_inv_LD		x		Working conditions - contact with quimical products	Environment & equipment
Q29h_inv_LD		x		Working conditions - cigarr smoking	Environment & equipment
Q29i_inv_LD		x		Working conditions - potentially infectious materials	Environment & equipment
Q30d_inv_LD		x		Working conditions - permanently seated	Environment & equipment
Q30f_inv_ReplaceMD_1		x		Working conditions - directly dealing with third people	Environment & equipment
Q30g_inv_ReplaceMD_1		x		Working conditions - dealing with boring people	Environment & equipment
Q30h_inv_ReplaceMD_1		x		Working conditions - dealing with anoyant situations	Environment & equipment
Q30i_inv_ReplaceMD_1		x		Working conditions - warking with computers/laptops/smartphones/...	Environment & equipment
Q31_dic_MV	x			Individual protection equipment	Environment & equipment
Q33_rect_inv		x		Working conditions - Safety and Health risks	Environment & equipment
Q61a_inv		x		Working conditions - co-workers help me and give support	Environment & equipment
Q61b_inv		x		Working conditions - Hierarchy help me and give support	Environment & equipment
Q73_dic_MV	x			Health and safety may become in risk due to the kind of tasks	Environment & equipment
Q80a_dic_MV	x			Consequences of the job - last month - subjected to verbal offenses	Environment & equipment
Q80c_dic_MV	x			Consequences of the job - last month - subjected to threats	Environment & equipment
Q80d_dic_MV	x			Consequences of the job - last month - subjected to humiliating behaviors	Environment & equipment
Q81a_dic_MV	x			Consequences of the job - last 12 months - subjected to physical violence	Environment & equipment
Q81c_dic_MV	x			Consequences of the job - last 12 months - subjected to harassment/bullying	Environment & equipment
Q18a_inv_LD		x		Work change last 12 months - hours	Home-work interface
Q18b_inv_LD		x		Work change last 12 months - salary	Home-work interface
Q18c_inv_LD		x		Work change last 12 months - impact on work	Home-work interface
Q18d_inv		x		Work change last 12 months - Duties & tasks	Home-work interface
Q44_rect		x		Adaptation of working time schedule to personnal commitments	Home-work interface
Q47_Rect		x		Working conditions - Getting free time to take care of personnal affairs	Home-work interface
Q100		x		Consequences of the job - wages at home reach the end of the month	Home-work interface

Tabla 8 (continuación)

Variable Name	Measure			Variable description	Group
	Nominal	Ordinal	Scale		
Total variables used	61	6	75		
Q63a_inv			x	Working conditions - my boss respects me as a human being	Interpersonal relationships at work
Q63b_inv			x	Working conditions - my boss congratulates me and recognize a task well done	Interpersonal relationships at work
Q63c_inv			x	Working conditions - my boss knows how to make people work as a team	Interpersonal relationships at work
Q63d_inv			x	Working conditions - my boss help me to get the work done	Interpersonal relationships at work
Q63e_inv			x	Working conditions - my boss gives feedback about my work	Interpersonal relationships at work
Q63f_inv			x	Working conditions - my boss encourages and supports my own development	Interpersonal relationships at work
Q65a_dic_MV	x			Training along last 12 months - made, payed or provided by own employer	Interpersonal relationships at work
Q65c_dic_MV	x			Training along last 12 months (workplace, shared with co-workers and supervisors)	Interpersonal relationships at work
Q23_cat		x		People working under supervision	Job content
Q48a_dic_MV	x			Working conditions - Work has brief and repetitive tasks taking less than 1 minute	Job content
Q48b_dic_MV	x			Working conditions - Work has brief and repetitive tasks taking less than 10 minutes	Job content
Q49a_inv			x	Working conditions - Working very fast	Job content
Q49b_inv			x	Working conditions - Working with very tight deadlines	Job content
Q53a_dic_MV	x			Working conditions - implications on main work - to respect specific quality standards	Job content
Q53b_dic_MV	x			Working conditions - implications on main work - assess the quality of own work	Job content
Q53c_dic_MV	x			Working conditions - implications on main work - solve unforeseen problems yourself	Job content
Q53d_dic_MV	x			Working conditions - implications on main work - to do monotonous tasks	Job content
Q53e_dic_MV	x			Working conditions - implications on main work - to do complex tasks	Job content
Q53f_dic_MV	x			Working conditions - implications on main work - learning new things	Job content
Q55_dic_MV	x			Working conditions - implications of tasks rotation among co-workers	Job content
Q61h_inv			x	Working conditions - feelings of doing a great job	Job content
Q61i_inv			x	Working conditions - put own ideas about work into practice	Job content
Q61j_inv			x	Working conditions - feelings of doing an useful work	Job content
Q61k_inv			x	Working conditions - knowing what is expected from me at work	Job content
Q61l_inv			x	Working conditions - people are fair to me at my workplace	Organizational culture
Q61n_inv			x	Working conditions - may influence in decisions that are important for the job	Organizational culture
Q70a_inv			x	Working conditions - workplace - the good work of employees is recognized	Organizational culture
Q70b_inv			x	Working conditions - workplace - management trusts on employees' work	Organizational culture
Q70c_inv			x	Working conditions - workplace - disagreements are solved in a fair way	Organizational culture
Q70d_inv			x	Working conditions - workplace - tasks are fairly distributed	Organizational culture
Q70e_inv			x	Working conditions - workplace - me and co-workers cooperate properly	Organizational culture
Q70f_inv			x	Working conditions - workplace - usually workers trust in management	Organizational culture
Q71a_dic_MV	x			There exists union, company committee, or similar that represents workers	Organizational culture
Q71b_dic_MV	x			There exists an health and safety delegate on working conditions	Organizational culture
Q71c_dic_MV	x			There happen usual meetings where employees express their points of view	Organizational culture
¹ Q89a_inv			x	Having into account all my efforts in work i believe my wage is fair	Organizational culture
¹ Q89b_inv			x	My job offers good chances of professional development	Organizational culture
¹ Q89c_inv			x	I get recognition for my job	Organizational culture
Q89d_inv			x	I get along well with my co-workers	Organizational culture
Q89e_inv			x	My company motivates me to do my best	Organizational culture
Q45a_inv			x	Last 12 months - worried with work even when out	Results & Effects
Q45b_inv			x	Last 12 months - very tired after work to take home duties	Results & Effects
Q45c_inv			x	Last 12 months - feeling with no time for family	Results & Effects
Q45d_inv			x	Last 12 months - being hard to focus on work because of family duties	Results & Effects
Q45e_inv			x	Last 12 months - feeling that family issues prevented from dedicating time to work	Results & Effects
Q61m_inv			x	Working conditions - get stressed at work	Results & Effects
Q78a_dic_MV	x			Consequences of the job - hearing problems	Results & Effects
Q78b_dic_MV	x			Consequences of the job - skin problems	Results & Effects
Q78c_dic_MV	x			Consequences of the job - back pain problems	Results & Effects
Q78d_dic_MV	x			Consequences of the job - Pain in shoulders, neck or upper extremities	Results & Effects
Q78e_dic_MV	x			Consequences of the job - muscle pain in lower extremities	Results & Effects
Q78f_dic_MV	x			Consequences of the job - head ache and tired eyes	Results & Effects
Q78g_dic_MV	x			Consequences of the job - injuries	Results & Effects
Q78h_dic_MV	x			Consequences of the job - anxiety	Results & Effects
Q78i_dic_MV	x			Consequences of the job - general tiredness	Results & Effects
Q79a_inv			x	Consequences of the job - difficulties to sleep	Results & Effects
Q79b_inv			x	Consequences of the job - sleep disorders	Results & Effects
Q79c_inv			x	Consequences of the job - wake-up with tiredness and fatigue	Results & Effects
Q87a_inv			x	Consequences of the job - last 2 weeks - found myself happy and in good mood	Results & Effects
Q87b_inv			x	Consequences of the job - last 2 weeks - found myself relaxed and quiet	Results & Effects
¹ Q87c_inv			x	Consequences of the job - last 2 weeks - found myself active and energetic	Results & Effects
¹ Q87d_inv			x	Consequences of the job - last 2 weeks - I wake up fresh and rested	Results & Effects
¹ Q87e_inv			x	Consequences of the job - last 2 weeks - everyday life has been full of interesting things	Results & Effects
Q88_inv			x	Consequences of the job - job satisfaction	Results & Effects
Q90a_inv			x	Consequences of the job - I feel myself full of energy	Results & Effects
Q90b_inv			x	Consequences of the job - I feel enthusiasm for my job	Results & Effects
Q90c_inv			x	Consequences of the job - time flies while I'm working	Results & Effects

Tabla 8 (continuación)

Variable Name	Measure			Variable description	Group
	Nominal	Ordinal	Scale		
Total variables used	61	6	75		
Q24_cat		x		Total of working hours per week	Workload & workplace
Q26_cat		x		Total of working days per week	Workload & workplace
Q37a_dic	x			Working conditions - night work	Workload & workplace
Q37b_dic	x			Working conditions - work some times/always on sundays	Workload & workplace
Q37c_dic	x			Working conditions - work some times/always on saturdays	Workload & workplace
Q37d_dic	x			Working conditions - work some times/always more than 10 hours a day	Workload & workplace
Q38_dic_inv	x			More than 11 hours between end of working day and beginning of next one	Workload & workplace
Q39a_dic	x			Working conditions - fixed number of hours every day	Workload & workplace
Q39b_dic	x			Working conditions - fixed number of days every week	Workload & workplace
Q39c_dic	x			Working conditions - fixed number of hours every week	Workload & workplace
Q39d_dic	x			Working conditions - fixed schedule for go in working and go out	Workload & workplace
Q39e_dic	x			Working conditions - work shifts	Workload & workplace
Q40_inv			x	Working conditions - last 12 months - frequency requiring antecipately to go working	Workload & workplace
Q46_inv			x	Working conditions - happening in last 12 months - needed working in free time left	Workload & workplace

¹ Variables that load as a factor, but are not related to ordinal or nominal variables

Tabla 9. Asociaciones entre variables de escala (dependientes) y nominales/ordinales (independientes), según grupo teórico, variable dependiente y variancia explicada

ASSOCIATIONS BETWEEN QUALITATIVE CONTROL/SEGMENTATION VARIABLES AND SCALE VARIABLES

GROUP	ΔΔ		ΔΔ		ETA value	Comments	Δ Explained Variance
	Variables Dependent	Independent	Measure	Type			
Control	Q43_inv	Q42_dic3	Nominal	dic.	0,674	STRONG RELATION	45,43%
Control	Q43_inv	Q42_dic1	Nominal	dic.	0,668	STRONG RELATION	44,62%
Control	Q43_inv	Q42_dic4	Nominal	dic.	0,318	STRONG RELATION	10,11%
Control	Q43_inv	Country	Nominal		0,313	STRONG RELATION	9,80%
Control	Q43_inv	Q54a_dic_MV	Nominal	dic.	0,165	MODERATE RELATION	2,72%
Control	Q43_inv	Q54b_dic_MV	Nominal	dic.	0,140	MODERATE RELATION	1,96%
Control	Q43_inv	Q52_dic2	Nominal	dic.	0,131	MODERATE RELATION	1,72%
Control	Q43_inv	Q52_dic1	Nominal	dic.	0,126	Small relation	1,59%
Control	Q43_inv	Q16b	Ordinal		0,119	Small relation	1,42%
Control	Q43_inv	Q15a	Nominal	dic.	0,104	Small relation	1,08%
Control	Q51_inv	Q52_dic2	Nominal	dic.	0,450	STRONG RELATION	20,25%
Control	Q51_inv	Q52_dic1	Nominal	dic.	0,429	STRONG RELATION	18,40%
Control	Q51_inv	Country	Nominal		0,304	STRONG RELATION	9,24%
Control	Q51_inv	Q50b_dic_MV	Nominal	dic.	0,183	MODERATE RELATION	3,35%
Control	Q51_inv	Q54a_dic_MV	Nominal	dic.	0,182	MODERATE RELATION	3,31%
Control	Q51_inv	Q58_dic_MV	Nominal	dic.	0,169	MODERATE RELATION	2,86%
Control	Q51_inv	Q50a_dic_MV	Nominal	dic.	0,168	MODERATE RELATION	2,82%
Control	Q51_inv	Q42_dic1	Nominal	dic.	0,160	MODERATE RELATION	2,56%
Control	Q51_inv	Q42_dic3	Nominal	dic.	0,155	MODERATE RELATION	2,40%
Control	Q51_inv	Q54b_dic_MV	Nominal	dic.	0,135	MODERATE RELATION	1,82%
Control	Q51_inv	Q16b	Ordinal		0,134	MODERATE RELATION	1,80%
Control	Q51_inv	Q15a	Nominal	dic.	0,106	Small relation	1,12%
Control	Q61c_inv	Q54a_dic_MV	Nominal	dic.	0,237	MODERATE RELATION	5,62%
Control	Q61c_inv	Q54b_dic_MV	Nominal	dic.	0,233	MODERATE RELATION	5,43%
Control	Q61c_inv	Q54c_dic_MV	Nominal	dic.	0,205	MODERATE RELATION	4,20%
Control	Q61c_inv	Country	Nominal		0,198	MODERATE RELATION	3,92%
Control	Q61c_inv	Q42_dic1	Nominal	dic.	0,158	MODERATE RELATION	2,50%
Control	Q61c_inv	Q58_dic_MV	Nominal	dic.	0,148	MODERATE RELATION	2,19%
Control	Q61c_inv	Q42_dic3	Nominal	dic.	0,129	Small relation	1,66%
Control	Q61d_inv	Q54b_dic_MV	Nominal	dic.	0,271	STRONG RELATION	7,34%
Control	Q61d_inv	Q54a_dic_MV	Nominal	dic.	0,269	STRONG RELATION	7,24%
Control	Q61d_inv	Q54c_dic_MV	Nominal	dic.	0,207	MODERATE RELATION	4,28%
Control	Q61d_inv	Country	Nominal		0,202	MODERATE RELATION	4,08%
Control	Q61d_inv	Q58_dic_MV	Nominal	dic.	0,186	MODERATE RELATION	3,46%
Control	Q61d_inv	Q42_dic1	Nominal	dic.	0,184	MODERATE RELATION	3,39%
Control	Q61d_inv	Q42_dic3	Nominal	dic.	0,145	MODERATE RELATION	2,10%
Control	Q61d_inv	Q50b_dic_MV	Nominal	dic.	0,102	Small relation	1,04%
Control	Q61d_inv	Q42_dic4	Nominal	dic.	0,101	Small relation	1,02%
Control	Q61d_inv	Q11_a	Nominal	dic.	0,100	Small relation	1,00%
Control	Q61e_inv	Country	Nominal		0,217	MODERATE RELATION	4,71%
Control	Q61e_inv	Q54a_dic_MV	Nominal	dic.	0,195	MODERATE RELATION	3,80%
Control	Q61e_inv	Q54b_dic_MV	Nominal	dic.	0,189	MODERATE RELATION	3,57%
Control	Q61e_inv	Q42_dic1	Nominal	dic.	0,157	MODERATE RELATION	2,46%
Control	Q61e_inv	Q54c_dic_MV	Nominal	dic.	0,149	MODERATE RELATION	2,22%
Control	Q61e_inv	Q42_dic4	Nominal	dic.	0,126	Small relation	1,59%
Control	Q61e_inv	Q58_dic_MV	Nominal	dic.	0,117	Small relation	1,37%
Control	Q61f_inv	Q54a_dic_MV	Nominal	dic.	0,320	STRONG RELATION	10,24%
Control	Q61f_inv	Q42_dic1	Nominal	dic.	0,280	STRONG RELATION	7,84%
Control	Q61f_inv	Q54c_dic_MV	Nominal	dic.	0,259	MODERATE RELATION	6,71%
Control	Q61f_inv	Q54b_dic_MV	Nominal	dic.	0,242	MODERATE RELATION	5,86%
Control	Q61f_inv	Q42_dic3	Nominal	dic.	0,241	MODERATE RELATION	5,81%
Control	Q61f_inv	Country	Nominal		0,178	MODERATE RELATION	3,17%
Control	Q61f_inv	Q42_dic4	Nominal	dic.	0,166	MODERATE RELATION	2,76%
Control	Q61f_inv	Q50e_dic_MV	Nominal	dic.	0,105	Small relation	1,10%
Control	Q61f_inv	Q50d_dic_MV	Nominal	dic.	0,104	Small relation	1,08%

Tabla 9 (continuación)

ASSOCIATIONS BETWEEN QUALITATIVE CONTROL/SEGMENTATION VARIABLES AND SCALE VARIABLES

GROUP	ΔΔΔ		ΔΔ		ETA value	Comments	Δ Explained Variance
	Dependent	Independent	Measure	Type			
Environment & equipment	Q29a_inv_ReplaceMD_1	Q31_dic_MV	Nominal	dic.	0,349	STRONG RELATION	12,18%
Environment & equipment	Q29a_inv_ReplaceMD_1	Q2a	Ordinal		0,268	STRONG RELATION	7,18%
Environment & equipment	Q29a_inv_ReplaceMD_1	Q73_dic_MV	Nominal	dic.	0,231	MODERATE RELATION	5,34%
Environment & equipment	Q29a_inv_ReplaceMD_1	Q14_a	Nominal	dic.	0,146	MODERATE RELATION	2,13%
Environment & equipment	Q29a_inv_ReplaceMD_1	Q14_b	Nominal	dic.	0,139	MODERATE RELATION	1,93%
Environment & equipment	Q29a_inv_ReplaceMD_1	Country	Nominal		0,125	Small relation	1,56%
Environment & equipment	Q29a_inv_ReplaceMD_1	Q2d Resumen	Nominal		0,108	Small relation	1,17%
Environment & equipment	Q29b_inv_ReplaceMD_1	Q31_dic_MV	Nominal	dic.	0,298	STRONG RELATION	8,88%
Environment & equipment	Q29b_inv_ReplaceMD_1	Q73_dic_MV	Nominal	dic.	0,262	STRONG RELATION	6,86%
Environment & equipment	Q29b_inv_ReplaceMD_1	Q2a	Ordinal		0,188	MODERATE RELATION	3,53%
Environment & equipment	Q29b_inv_ReplaceMD_1	Country	Nominal		0,133	MODERATE RELATION	1,77%
Environment & equipment	Q29c_inv_ReplaceMD_1	Q31_dic_MV	Nominal	dic.	0,285	STRONG RELATION	8,12%
Environment & equipment	Q29c_inv_ReplaceMD_1	Q73_dic_MV	Nominal	dic.	0,266	STRONG RELATION	7,08%
Environment & equipment	Q29c_inv_ReplaceMD_1	Q2a	Ordinal		0,183	MODERATE RELATION	3,35%
Environment & equipment	Q29c_inv_ReplaceMD_1	Country	Nominal		0,177	MODERATE RELATION	3,13%
Environment & equipment	Q29d_inv_ReplaceMD_1	Q31_dic_MV	Nominal	dic.	0,277	STRONG RELATION	7,67%
Environment & equipment	Q29d_inv_ReplaceMD_1	Q73_dic_MV	Nominal	dic.	0,240	MODERATE RELATION	5,76%
Environment & equipment	Q29d_inv_ReplaceMD_1	Q2a	Ordinal		0,213	MODERATE RELATION	4,54%
Environment & equipment	Q29d_inv_ReplaceMD_1	Country	Nominal		0,131	MODERATE RELATION	1,72%
Environment & equipment	Q29e_inv_ReplaceMD_1	Q31_dic_MV	Nominal	dic.	0,332	STRONG RELATION	11,02%
Environment & equipment	Q29e_inv_ReplaceMD_1	Q73_dic_MV	Nominal	dic.	0,276	STRONG RELATION	7,62%
Environment & equipment	Q29e_inv_ReplaceMD_1	Q2a	Ordinal		0,265	STRONG RELATION	7,02%
Environment & equipment	Q29e_inv_ReplaceMD_1	Q14_a	Nominal	dic.	0,100	Small relation	1,00%
Environment & equipment	Q29e_inv_ReplaceMD_1	Country	Nominal		0,100	Small relation	1,00%
Environment & equipment	Q29f_inv_LD	Q31_dic_MV	Nominal	dic.	0,299	STRONG RELATION	8,94%
Environment & equipment	Q29f_inv_LD	Q73_dic_MV	Nominal	dic.	0,223	MODERATE RELATION	4,97%
Environment & equipment	Q29f_inv_LD	Q2a	Ordinal		0,146	MODERATE RELATION	2,13%
Environment & equipment	Q29f_inv_LD	Country	Nominal		0,106	Small relation	1,12%
Environment & equipment	Q29g_inv_LD	Q31_dic_MV	Nominal	dic.	0,359	STRONG RELATION	12,89%
Environment & equipment	Q29g_inv_LD	Q73_dic_MV	Nominal	dic.	0,229	MODERATE RELATION	5,24%
Environment & equipment	Q29h_inv_LD	Country	Nominal		0,159	MODERATE RELATION	2,53%
Environment & equipment	Q29h_inv_LD	Q2a	Ordinal		0,155	MODERATE RELATION	2,40%
Environment & equipment	Q29h_inv_LD	Q31_dic_MV	Nominal	dic.	0,141	MODERATE RELATION	1,99%
Environment & equipment	Q29h_inv_LD	Q73_dic_MV	Nominal	dic.	0,138	MODERATE RELATION	1,90%
Environment & equipment	Q29i_inv_LD	Q31_dic_MV	Nominal	dic.	0,306	STRONG RELATION	9,36%
Environment & equipment	Q29i_inv_LD	Q73_dic_MV	Nominal	dic.	0,217	MODERATE RELATION	4,71%
Environment & equipment	Q29i_inv_LD	Q81a_dic_MV	Nominal	dic.	0,158	MODERATE RELATION	2,50%
Environment & equipment	Q29i_inv_LD	Q14_a	Nominal	dic.	0,130	MODERATE RELATION	1,69%
Environment & equipment	Q29i_inv_LD	Q14_b	Nominal	dic.	0,123	Small relation	1,51%
Environment & equipment	Q29i_inv_LD	Q80a_dic_MV	Nominal	dic.	0,115	Small relation	1,32%
Environment & equipment	Q29i_inv_LD	Q80c_dic_MV	Nominal	dic.	0,104	Small relation	1,08%
Environment & equipment	Q30d_inv_LD	Q31_dic_MV	Nominal	dic.	0,321	STRONG RELATION	10,30%
Environment & equipment	Q30d_inv_LD	Q16b	Ordinal		0,138	MODERATE RELATION	1,90%
Environment & equipment	Q30d_inv_LD	Q73_dic_MV	Nominal	dic.	0,115	Small relation	1,32%
Environment & equipment	Q30d_inv_LD	Country	Nominal		0,110	Small relation	1,21%
Environment & equipment	Q30f_inv_ReplaceMD_1	Q2a	Ordinal		0,180	MODERATE RELATION	3,24%
Environment & equipment	Q30f_inv_ReplaceMD_1	Country	Nominal		0,167	MODERATE RELATION	2,79%
Environment & equipment	Q30f_inv_ReplaceMD_1	Q80a_dic_MV	Nominal	dic.	0,141	MODERATE RELATION	1,99%
Environment & equipment	Q30f_inv_ReplaceMD_1	Q31_dic_MV	Nominal	dic.	0,139	MODERATE RELATION	1,93%
Environment & equipment	Q30f_inv_ReplaceMD_1	Q80c_dic_MV	Nominal	dic.	0,111	Small relation	1,23%
Environment & equipment	Q30f_inv_ReplaceMD_1	Q14_a	Nominal	dic.	0,108	Small relation	1,17%
Environment & equipment	Q30f_inv_ReplaceMD_1	Q14_b	Nominal	dic.	0,104	Small relation	1,08%
Environment & equipment	Q30g_inv_ReplaceMD_1	Country	Nominal		0,213	MODERATE RELATION	4,54%
Environment & equipment	Q30g_inv_ReplaceMD_1	Q80a_dic_MV	Nominal	dic.	0,180	MODERATE RELATION	3,24%
Environment & equipment	Q30g_inv_ReplaceMD_1	Q80c_dic_MV	Nominal	dic.	0,172	MODERATE RELATION	2,96%
Environment & equipment	Q30g_inv_ReplaceMD_1	Q80d_dic_MV	Nominal	dic.	0,135	MODERATE RELATION	1,82%
Environment & equipment	Q30g_inv_ReplaceMD_1	Q81a_dic_MV	Nominal	dic.	0,129	Small relation	1,66%
Environment & equipment	Q30g_inv_ReplaceMD_1	Q81c_dic_MV	Nominal	dic.	0,107	Small relation	1,14%
Environment & equipment	Q30g_inv_ReplaceMD_1	Q2a	Ordinal		0,106	Small relation	1,12%
Environment & equipment	Q30g_inv_ReplaceMD_1	Q14_b	Nominal	dic.	0,105	Small relation	1,10%
Environment & equipment	Q30g_inv_ReplaceMD_1	Q14_a	Nominal	dic.	0,100	Small relation	1,00%

Tabla 9 (continuación)

ASSOCIATIONS BETWEEN QUALITATIVE CONTROL/SEGMENTATION VARIABLES AND SCALE VARIABLES

GROUP	ΔΔΔ		ΔΔ		ETA value	Comments	Δ Explained Variance
	Dependent	Independent	Measure	Type			
Environment & equipment	Q30h_inv_ReplaceMD_1	Q80a_dic_MV	Nominal	dic.	0,232	MODERATE RELATION	5,38%
Environment & equipment	Q30h_inv_ReplaceMD_1	Q80c_dic_MV	Nominal	dic.	0,218	MODERATE RELATION	4,75%
Environment & equipment	Q30h_inv_ReplaceMD_1	Q73_dic_MV	Nominal	dic.	0,215	MODERATE RELATION	4,62%
Environment & equipment	Q30h_inv_ReplaceMD_1	Q80d_dic_MV	Nominal	dic.	0,207	MODERATE RELATION	4,28%
Environment & equipment	Q30h_inv_ReplaceMD_1	Q81c_dic_MV	Nominal	dic.	0,175	MODERATE RELATION	3,06%
Environment & equipment	Q30h_inv_ReplaceMD_1	Country	Nominal		0,164	MODERATE RELATION	2,69%
Environment & equipment	Q30h_inv_ReplaceMD_1	Q14_a	Nominal	dic.	0,162	MODERATE RELATION	2,62%
Environment & equipment	Q30h_inv_ReplaceMD_1	Q14_b	Nominal	dic.	0,155	MODERATE RELATION	2,40%
Environment & equipment	Q30h_inv_ReplaceMD_1	Q81a_dic_MV	Nominal	dic.	0,138	MODERATE RELATION	1,90%
Environment & equipment	Q30h_inv_ReplaceMD_1	Q2a	Ordinal		0,101	Small relation	1,02%
Environment & equipment	Q30i_inv_ReplaceMD_1	Q31_dic_MV	Nominal	dic.	0,281	STRONG RELATION	7,90%
Environment & equipment	Q30i_inv_ReplaceMD_1	Country	Nominal		0,230	MODERATE RELATION	5,29%
Environment & equipment	Q30i_inv_ReplaceMD_1	Q16b	Ordinal		0,203	MODERATE RELATION	4,12%
Environment & equipment	Q30i_inv_ReplaceMD_1	Q15a	Nominal	dic.	0,160	MODERATE RELATION	2,56%
Environment & equipment	Q30i_inv_ReplaceMD_1	Q73_dic_MV	Nominal	dic.	0,120	Small relation	1,44%
Environment & equipment	Q33_rect_inv	Country	Nominal		0,212	MODERATE RELATION	4,49%
Environment & equipment	Q61a_inv	Country	Nominal		0,226	MODERATE RELATION	5,11%
Environment & equipment	Q61b_inv	Country	Nominal		0,235	MODERATE RELATION	5,52%
Environment & equipment	Q61b_inv	Q81c_dic_MV	Nominal	dic.	0,148	MODERATE RELATION	2,19%
Environment & equipment	Q61b_inv	Q80d_dic_MV	Nominal	dic.	0,147	MODERATE RELATION	2,16%
Environment & equipment	Q61b_inv	Q73_dic_MV	Nominal	dic.	0,120	Small relation	1,44%
Environment & equipment	Q61b_inv	Q80a_dic_MV	Nominal	dic.	0,115	Small relation	1,32%
Home-work interface	Q100	Country	Nominal		0,427	STRONG RELATION	18,23%
Home-work interface	Q100	Q16b	Ordinal		0,157	MODERATE RELATION	2,46%
Home-work interface	Q100	Q11_a	Nominal	dic.	0,122	Small relation	1,49%
Home-work interface	Q100	Q11_b	Nominal	dic.	0,115	Small relation	1,32%
Home-work interface	Q100	Q15a	Nominal	dic.	0,110	Small relation	1,21%
Home-work interface	Q18a_inv_LD	Q2a	Ordinal		0,110	Small relation	1,21%
Home-work interface	Q18a_inv_LD	Country	Nominal		0,107	Small relation	1,14%
Home-work interface	Q18b_inv_LD	Country	Nominal		0,337	STRONG RELATION	11,36%
Home-work interface	Q18c_inv_LD	Country	Nominal		0,164	MODERATE RELATION	2,69%
Home-work interface	Q18c_inv_LD	Q2b_Cat	Ordinal		0,115	Small relation	1,32%
Home-work interface	Q18d_inv	Country	Nominal		0,175	MODERATE RELATION	3,06%
Home-work interface	Q18d_inv	Q16b	Ordinal		0,113	Small relation	1,28%
Home-work interface	Q44_Rect	Country	Nominal		0,155	MODERATE RELATION	2,40%
Home-work interface	Q44_Rect	Q2d_Resumen	Nominal		0,113	Small relation	1,28%
Home-work interface	Q47_Rect	Country	Nominal		0,283	STRONG RELATION	8,01%
Interpersonal relationships at work	Q63a_inv	Country	Nominal		0,167	MODERATE RELATION	2,79%
Interpersonal relationships at work	Q63b_inv	Country	Nominal		0,180	MODERATE RELATION	3,24%
Interpersonal relationships at work	Q63b_inv	Q65c_dic_MV	Nominal	dic.	0,110	Small relation	1,21%
Interpersonal relationships at work	Q63c_inv	Country	Nominal		0,161	MODERATE RELATION	2,59%
Interpersonal relationships at work	Q63d_inv	Country	Nominal		0,247	MODERATE RELATION	6,10%
Interpersonal relationships at work	Q63e_inv	Country	Nominal		0,142	MODERATE RELATION	2,02%
Interpersonal relationships at work	Q63f_inv	Country	Nominal		0,178	MODERATE RELATION	3,17%
Interpersonal relationships at work	Q63f_inv	Q65c_dic_MV	Nominal	dic.	0,136	MODERATE RELATION	1,85%
Interpersonal relationships at work	Q63f_inv	Q65a_dic_MV	Nominal	dic.	0,132	MODERATE RELATION	1,74%
Job content	Q49a_inv	Country	Nominal		0,238	MODERATE RELATION	5,66%
Job content	Q49a_inv	Q48b_dic_MV	Nominal	dic.	0,237	MODERATE RELATION	5,62%
Job content	Q49a_inv	Q48a_dic_MV	Nominal	dic.	0,224	MODERATE RELATION	5,02%
Job content	Q49a_inv	Q53a_dic_MV	Nominal	dic.	0,178	MODERATE RELATION	3,17%
Job content	Q49a_inv	Q53d_dic_MV	Nominal	dic.	0,162	MODERATE RELATION	2,62%
Job content	Q49a_inv	Q55_dic_MV	Nominal	dic.	0,129	Small relation	1,66%
Job content	Q49a_inv	Q14_a	Nominal	dic.	0,120	Small relation	1,44%
Job content	Q49a_inv	Q2b_Cat	Ordinal		0,112	Small relation	1,25%
Job content	Q49a_inv	Q53e_dic_MV	Nominal	dic.	0,109	Small relation	1,19%
Job content	Q49a_inv	Q14_b	Nominal	dic.	0,109	Small relation	1,19%

Tabla 9 (continuación)

ASSOCIATIONS BETWEEN QUALITATIVE CONTROL/SEGMENTATION VARIABLES AND SCALE VARIABLES

GROUP	ΔΔΔ		ΔΔ		ETA value	Comments	Δ Explained Variance
	Dependent	Independent	Measure	Type			
Job content	Q49b_inv	Q53a_dic_MV	Nominal	dic.	0,207	MODERATE RELATION	4,28%
Job content	Q49b_inv	Q53e_dic_MV	Nominal	dic.	0,191	MODERATE RELATION	3,65%
Job content	Q49b_inv	Country	Nominal		0,184	MODERATE RELATION	3,39%
Job content	Q49b_inv	Q48b_dic_MV	Nominal	dic.	0,168	MODERATE RELATION	2,82%
Job content	Q49b_inv	Q48a_dic_MV	Nominal	dic.	0,155	MODERATE RELATION	2,40%
Job content	Q49b_inv	Q53d_dic_MV	Nominal	dic.	0,131	MODERATE RELATION	1,72%
Job content	Q49b_inv	Q53b_dic_MV	Nominal	dic.	0,116	Small relation	1,35%
Job content	Q49b_inv	Q53f_dic_MV	Nominal	dic.	0,109	Small relation	1,19%
Job content	Q49b_inv	Q14_a	Nominal	dic.	0,103	Small relation	1,06%
Job content	Q49b_inv	Q55_dic_MV	Nominal	dic.	0,101	Small relation	1,02%
Job content	Q49b_inv	Q53c_dic_MV	Nominal	dic.	0,101	Small relation	1,02%
Job content	Q61h_inv	Country	Nominal		0,187	MODERATE RELATION	3,50%
Job content	Q61h_inv	Q53f_dic_MV	Nominal	dic.	0,135	MODERATE RELATION	1,82%
Job content	Q61h_inv	Q53d_dic_MV	Nominal	dic.	0,105	Small relation	1,10%
Job content	Q61i_inv	Q53f_dic_MV	Nominal	dic.	0,290	STRONG RELATION	8,41%
Job content	Q61i_inv	Q53c_dic_MV	Nominal	dic.	0,247	MODERATE RELATION	6,10%
Job content	Q61i_inv	Country	Nominal		0,244	MODERATE RELATION	5,95%
Job content	Q61i_inv	Q53b_dic_MV	Nominal	dic.	0,202	MODERATE RELATION	4,08%
Job content	Q61i_inv	Q53e_dic_MV	Nominal	dic.	0,196	MODERATE RELATION	3,84%
Job content	Q61i_inv	Q23_cat	Ordinal		0,170	MODERATE RELATION	2,89%
Job content	Q61i_inv	Q53d_dic_MV	Nominal	dic.	0,152	MODERATE RELATION	2,31%
Job content	Q61j_inv	Q53f_dic_MV	Nominal	dic.	0,168	MODERATE RELATION	2,82%
Job content	Q61j_inv	Country	Nominal		0,145	MODERATE RELATION	2,10%
Job content	Q61j_inv	Q53d_dic_MV	Nominal	dic.	0,128	Small relation	1,64%
Job content	Q61j_inv	Q14_a	Nominal	dic.	0,115	Small relation	1,32%
Job content	Q61j_inv	Q53c_dic_MV	Nominal	dic.	0,109	Small relation	1,19%
Job content	Q61j_inv	Q53b_dic_MV	Nominal	dic.	0,105	Small relation	1,10%
Job content	Q61j_inv	Q14_b	Nominal	dic.	0,105	Small relation	1,10%
Job content	Q61j_inv	Q53e_dic_MV	Nominal	dic.	0,101	Small relation	1,02%
Job content	Q61k_inv	Country	Nominal		0,179	MODERATE RELATION	3,20%
Organizational culture	Q61l_inv	Country	Nominal		0,163	MODERATE RELATION	2,66%
Organizational culture	Q61l_inv	Q71c_dic_MV	Nominal	dic.	0,159	MODERATE RELATION	2,53%
Organizational culture	Q61n_inv	Country	Nominal		0,204	MODERATE RELATION	4,16%
Organizational culture	Q61n_inv	Q71c_dic_MV	Nominal	dic.	0,192	MODERATE RELATION	3,69%
Organizational culture	Q61n_inv	Q11_a	Nominal	dic.	0,103	Small relation	1,06%
Organizational culture	Q70a_inv	Q71c_dic_MV	Nominal	dic.	0,180	MODERATE RELATION	3,24%
Organizational culture	Q70a_inv	Country	Nominal		0,176	MODERATE RELATION	3,10%
Organizational culture	Q70a_inv	Q16b	Ordinal		0,105	Small relation	1,10%
Organizational culture	Q70b_inv	Country	Nominal		0,180	MODERATE RELATION	3,24%
Organizational culture	Q70b_inv	Q71c_dic_MV	Nominal	dic.	0,148	MODERATE RELATION	2,19%
Organizational culture	Q70c_inv	Country	Nominal		0,172	MODERATE RELATION	2,96%
Organizational culture	Q70c_inv	Q71c_dic_MV	Nominal	dic.	0,142	MODERATE RELATION	2,02%
Organizational culture	Q70c_inv	Q16b	Ordinal		0,127	Small relation	1,61%
Organizational culture	Q70d_inv	Country	Nominal		0,144	MODERATE RELATION	2,07%
Organizational culture	Q70d_inv	Q71c_dic_MV	Nominal	dic.	0,127	Small relation	1,61%
Organizational culture	Q70d_inv	Q16b	Ordinal		0,123	Small relation	1,51%
Organizational culture	Q70e_inv	Country	Nominal		0,223	MODERATE RELATION	4,97%
Organizational culture	Q70e_inv	Q71c_dic_MV	Nominal	dic.	0,147	MODERATE RELATION	2,16%
Organizational culture	Q70f_inv	Country	Nominal		0,201	MODERATE RELATION	4,04%
Organizational culture	Q70f_inv	Q16b	Ordinal		0,197	MODERATE RELATION	3,88%
Organizational culture	Q70f_inv	Q15a	Nominal	dic.	0,125	Small relation	1,56%
Organizational culture	Q70f_inv	Q15a	Nominal	dic.	0,125	Small relation	1,56%
Organizational culture	Q70f_inv	Q71a_dic_MV	Nominal	dic.	0,121	Small relation	1,46%
Organizational culture	Q70f_inv	Q71c_dic_MV	Nominal	dic.	0,112	Small relation	1,25%
Organizational culture	Q89d_inv	Country	Nominal		0,251	MODERATE RELATION	6,30%
Organizational culture	Q89d_inv	Q71c_dic_MV	Nominal	dic.	0,145	MODERATE RELATION	2,10%
Organizational culture	Q89d_inv	Q71b_dic_MV	Nominal	dic.	0,102	Small relation	1,04%
Organizational culture	Q89e_inv	Q71c_dic_MV	Nominal	dic.	0,205	MODERATE RELATION	4,20%
Organizational culture	Q89e_inv	Country	Nominal		0,150	MODERATE RELATION	2,25%

Tabla 9 (continuación)

ASSOCIATIONS BETWEEN QUALITATIVE CONTROL/SEGMENTATION VARIABLES AND SCALE VARIABLES

GROUP	ΔΔΔ		ΔΔ			ETA value	Comments	Δ Explained Variance
	Variables Dependent	Independent	Measure	Type				
Results & Effects	Q45a_inv	Q78h_dic_MV	Nominal	dic.	0,244	MODERATE RELATION	5,95%	
Results & Effects	Q45a_inv	Country	Nominal		0,227	MODERATE RELATION	5,15%	
Results & Effects	Q45a_inv	Q78i_dic_MV	Nominal	dic.	0,222	MODERATE RELATION	4,93%	
Results & Effects	Q45a_inv	Q78f_dic_MV	Nominal	dic.	0,171	MODERATE RELATION	2,92%	
Results & Effects	Q45a_inv	Q78d_dic_MV	Nominal	dic.	0,138	MODERATE RELATION	1,90%	
Results & Effects	Q45a_inv	Q78c_dic_MV	Nominal	dic.	0,111	Small relation	1,23%	
Results & Effects	Q45b_inv	Q78i_dic_MV	Nominal	dic.	0,347	STRONG RELATION	12,04%	
Results & Effects	Q45b_inv	Q78d_dic_MV	Nominal	dic.	0,240	MODERATE RELATION	5,76%	
Results & Effects	Q45b_inv	Q78e_dic_MV	Nominal	dic.	0,224	MODERATE RELATION	5,02%	
Results & Effects	Q45b_inv	Q78h_dic_MV	Nominal	dic.	0,221	MODERATE RELATION	4,88%	
Results & Effects	Q45b_inv	Q78c_dic_MV	Nominal	dic.	0,220	MODERATE RELATION	4,84%	
Results & Effects	Q45b_inv	Q78f_dic_MV	Nominal	dic.	0,214	MODERATE RELATION	4,58%	
Results & Effects	Q45b_inv	Country	Nominal		0,197	MODERATE RELATION	3,88%	
Results & Effects	Q45c_inv	Q78i_dic_MV	Nominal	dic.	0,241	MODERATE RELATION	5,81%	
Results & Effects	Q45c_inv	Q78h_dic_MV	Nominal	dic.	0,173	MODERATE RELATION	2,99%	
Results & Effects	Q45c_inv	Q78d_dic_MV	Nominal	dic.	0,160	MODERATE RELATION	2,56%	
Results & Effects	Q45c_inv	Q78f_dic_MV	Nominal	dic.	0,157	MODERATE RELATION	2,46%	
Results & Effects	Q45c_inv	Country	Nominal		0,145	MODERATE RELATION	2,10%	
Results & Effects	Q45c_inv	Q78c_dic_MV	Nominal	dic.	0,143	MODERATE RELATION	2,04%	
Results & Effects	Q45c_inv	Q78e_dic_MV	Nominal	dic.	0,141	MODERATE RELATION	1,99%	
Results & Effects	Q45c_inv	Q2b_Cat	Ordinal		0,131	MODERATE RELATION	1,72%	
Results & Effects	Q45d_inv	Country	Nominal		0,181	MODERATE RELATION	3,28%	
Results & Effects	Q45d_inv	Q78i_dic_MV	Nominal	dic.	0,157	MODERATE RELATION	2,46%	
Results & Effects	Q45d_inv	Q78h_dic_MV	Nominal	dic.	0,138	MODERATE RELATION	1,90%	
Results & Effects	Q45d_inv	Q78f_dic_MV	Nominal	dic.	0,129	Small relation	1,66%	
Results & Effects	Q45d_inv	Q2b_Cat	Ordinal		0,113	Small relation	1,28%	
Results & Effects	Q45d_inv	Q78d_dic_MV	Nominal	dic.	0,101	Small relation	1,02%	
Results & Effects	Q45d_inv	Q78c_dic_MV	Nominal	dic.	0,100	Small relation	1,00%	
Results & Effects	Q45e_inv	Country	Nominal		0,183	MODERATE RELATION	3,35%	
Results & Effects	Q45e_inv	Q78i_dic_MV	Nominal	dic.	0,109	Small relation	1,19%	
Results & Effects	Q45e_inv	Q2b_Cat	Ordinal		0,105	Small relation	1,10%	
Results & Effects	Q61m_inv	Q78h_dic_MV	Nominal	dic.	0,252	MODERATE RELATION	6,35%	
Results & Effects	Q61m_inv	Q78i_dic_MV	Nominal	dic.	0,218	MODERATE RELATION	4,75%	
Results & Effects	Q61m_inv	Country	Nominal		0,190	MODERATE RELATION	3,61%	
Results & Effects	Q61m_inv	Q78f_dic_MV	Nominal	dic.	0,158	MODERATE RELATION	2,50%	
Results & Effects	Q61m_inv	Q78d_dic_MV	Nominal	dic.	0,155	MODERATE RELATION	2,40%	
Results & Effects	Q61m_inv	Q78c_dic_MV	Nominal	dic.	0,137	MODERATE RELATION	1,88%	
Results & Effects	Q61m_inv	Q78e_dic_MV	Nominal	dic.	0,111	Small relation	1,23%	
Results & Effects	Q61m_inv	Q16b	Ordinal		0,107	Small relation	1,14%	
Results & Effects	Q79a_inv	Q78i_dic_MV	Nominal	dic.	0,261	STRONG RELATION	6,81%	
Results & Effects	Q79a_inv	Q78h_dic_MV	Nominal	dic.	0,257	MODERATE RELATION	6,60%	
Results & Effects	Q79a_inv	Q78f_dic_MV	Nominal	dic.	0,230	MODERATE RELATION	5,29%	
Results & Effects	Q79a_inv	Q78d_dic_MV	Nominal	dic.	0,223	MODERATE RELATION	4,97%	
Results & Effects	Q79a_inv	Q78c_dic_MV	Nominal	dic.	0,208	MODERATE RELATION	4,33%	
Results & Effects	Q79a_inv	Q78e_dic_MV	Nominal	dic.	0,203	MODERATE RELATION	4,12%	
Results & Effects	Q79a_inv	Country	Nominal		0,142	MODERATE RELATION	2,02%	
Results & Effects	Q79a_inv	Q78b_dic_MV	Nominal	dic.	0,112	Small relation	1,25%	
Results & Effects	Q79b_inv	Q78i_dic_MV	Nominal	dic.	0,258	MODERATE RELATION	6,66%	
Results & Effects	Q79b_inv	Q78d_dic_MV	Nominal	dic.	0,248	MODERATE RELATION	6,15%	
Results & Effects	Q79b_inv	Q78h_dic_MV	Nominal	dic.	0,241	MODERATE RELATION	5,81%	
Results & Effects	Q79b_inv	Country	Nominal		0,237	MODERATE RELATION	5,62%	
Results & Effects	Q79b_inv	Q78e_dic_MV	Nominal	dic.	0,222	MODERATE RELATION	4,93%	
Results & Effects	Q79b_inv	Q78c_dic_MV	Nominal	dic.	0,221	MODERATE RELATION	4,88%	
Results & Effects	Q79b_inv	Q78f_dic_MV	Nominal	dic.	0,214	MODERATE RELATION	4,58%	
Results & Effects	Q79b_inv	Q2b_Cat	Ordinal		0,137	MODERATE RELATION	1,88%	
Results & Effects	Q79b_inv	Q78b_dic_MV	Nominal	dic.	0,130	MODERATE RELATION	1,69%	
Results & Effects	Q79b_inv	Q78a_dic_MV	Nominal	dic.	0,118	Small relation	1,39%	
Results & Effects	Q79b_inv	Q16b	Ordinal		0,108	Small relation	1,17%	

Tabla 9 (continuación)

ASSOCIATIONS BETWEEN QUALITATIVE CONTROL/SEGMENTATION VARIABLES AND SCALE VARIABLES

GROUP	ΔΔΔ		ΔΔ		ETA value	Comments	Δ Explained Variance
	Dependent	Independent	Measure	Type			
Results & Effects	Q79c_inv	Q78i_dic_MV	Nominal	dic.	0,387	STRONG RELATION	14,98%
Results & Effects	Q79c_inv	Q78h_dic_MV	Nominal	dic.	0,301	STRONG RELATION	9,06%
Results & Effects	Q79c_inv	Q78d_dic_MV	Nominal	dic.	0,285	STRONG RELATION	8,12%
Results & Effects	Q79c_inv	Q78f_dic_MV	Nominal	dic.	0,284	STRONG RELATION	8,07%
Results & Effects	Q79c_inv	Q78e_dic_MV	Nominal	dic.	0,262	STRONG RELATION	6,86%
Results & Effects	Q79c_inv	Q78c_dic_MV	Nominal	dic.	0,254	MODERATE RELATION	6,45%
Results & Effects	Q79c_inv	Country	Nominal		0,180	MODERATE RELATION	3,24%
Results & Effects	Q79c_inv	Q78b_dic_MV	Nominal	dic.	0,147	MODERATE RELATION	2,16%
Results & Effects	Q79c_inv	Q78g_dic_MV	Nominal	dic.	0,104	Small relation	1,08%
Results & Effects	Q87a_inv	Q78i_dic_MV	Nominal	dic.	0,238	MODERATE RELATION	5,66%
Results & Effects	Q87a_inv	Q78h_dic_MV	Nominal	dic.	0,229	MODERATE RELATION	5,24%
Results & Effects	Q87a_inv	Q78c_dic_MV	Nominal	dic.	0,176	MODERATE RELATION	3,10%
Results & Effects	Q87a_inv	Q78e_dic_MV	Nominal	dic.	0,170	MODERATE RELATION	2,89%
Results & Effects	Q87a_inv	Q78d_dic_MV	Nominal	dic.	0,169	MODERATE RELATION	2,86%
Results & Effects	Q87a_inv	Country	Nominal		0,165	MODERATE RELATION	2,72%
Results & Effects	Q87a_inv	Q78f_dic_MV	Nominal	dic.	0,160	MODERATE RELATION	2,56%
Results & Effects	Q87b_inv	Q78h_dic_MV	Nominal	dic.	0,285	STRONG RELATION	8,12%
Results & Effects	Q87b_inv	Q78i_dic_MV	Nominal	dic.	0,281	STRONG RELATION	7,90%
Results & Effects	Q87b_inv	Q78d_dic_MV	Nominal	dic.	0,208	MODERATE RELATION	4,33%
Results & Effects	Q87b_inv	Q78c_dic_MV	Nominal	dic.	0,203	MODERATE RELATION	4,12%
Results & Effects	Q87b_inv	Q78f_dic_MV	Nominal	dic.	0,200	MODERATE RELATION	4,00%
Results & Effects	Q87b_inv	Q78e_dic_MV	Nominal	dic.	0,182	MODERATE RELATION	3,31%
Results & Effects	Q87b_inv	Country	Nominal		0,137	MODERATE RELATION	1,88%
Results & Effects	Q87b_inv	Q78b_dic_MV	Nominal	dic.	0,116	Small relation	1,35%
Results & Effects	Q88_inv	Q78i_dic_MV	Nominal	dic.	0,221	MODERATE RELATION	4,88%
Results & Effects	Q88_inv	Q78h_dic_MV	Nominal	dic.	0,182	MODERATE RELATION	3,31%
Results & Effects	Q88_inv	Q78e_dic_MV	Nominal	dic.	0,180	MODERATE RELATION	3,24%
Results & Effects	Q88_inv	Q78c_dic_MV	Nominal	dic.	0,179	MODERATE RELATION	3,20%
Results & Effects	Q88_inv	Q78d_dic_MV	Nominal	dic.	0,174	MODERATE RELATION	3,03%
Results & Effects	Q88_inv	Country	Nominal		0,173	MODERATE RELATION	2,99%
Results & Effects	Q88_inv	Q78f_dic_MV	Nominal	dic.	0,121	Small relation	1,46%
Results & Effects	Q90a_inv	Q78i_dic_MV	Nominal	dic.	0,194	MODERATE RELATION	3,76%
Results & Effects	Q90a_inv	Q78h_dic_MV	Nominal	dic.	0,168	MODERATE RELATION	2,82%
Results & Effects	Q90a_inv	Q78d_dic_MV	Nominal	dic.	0,168	MODERATE RELATION	2,82%
Results & Effects	Q90a_inv	Q78c_dic_MV	Nominal	dic.	0,167	MODERATE RELATION	2,79%
Results & Effects	Q90a_inv	Q78e_dic_MV	Nominal	dic.	0,150	MODERATE RELATION	2,25%
Results & Effects	Q90a_inv	Country	Nominal		0,148	MODERATE RELATION	2,19%
Results & Effects	Q90a_inv	Q78f_dic_MV	Nominal	dic.	0,135	MODERATE RELATION	1,82%
Results & Effects	Q90b_inv	Country	Nominal		0,250	MODERATE RELATION	6,25%
Results & Effects	Q90b_inv	Q78c_dic_MV	Nominal	dic.	0,138	MODERATE RELATION	1,90%
Results & Effects	Q90b_inv	Q78i_dic_MV	Nominal	dic.	0,131	MODERATE RELATION	1,72%
Results & Effects	Q90b_inv	Q78e_dic_MV	Nominal	dic.	0,124	Small relation	1,54%
Results & Effects	Q90b_inv	Q78d_dic_MV	Nominal	dic.	0,115	Small relation	1,32%
Results & Effects	Q90b_inv	Q78h_dic_MV	Nominal	dic.	0,102	Small relation	1,04%
Results & Effects	Q90c_inv	Country	Nominal		0,221	MODERATE RELATION	4,88%
Workload & workpace	Q40_inv	Q37c_dic	Nominal	dic.	0,263	STRONG RELATION	6,92%
Workload & workpace	Q40_inv	Q39b_dic	Nominal	dic.	0,245	MODERATE RELATION	6,00%
Workload & workpace	Q40_inv	Q37b_dic	Nominal	dic.	0,243	MODERATE RELATION	5,90%
Workload & workpace	Q40_inv	Q39c_dic	Nominal	dic.	0,234	MODERATE RELATION	5,48%
Workload & workpace	Q40_inv	Q37a_dic	Nominal	dic.	0,221	MODERATE RELATION	4,88%
Workload & workpace	Q40_inv	Q38_dic_inv	Nominal	dic.	0,193	MODERATE RELATION	3,72%
Workload & workpace	Q40_inv	Q37d_dic	Nominal	dic.	0,190	MODERATE RELATION	3,61%
Workload & workpace	Q40_inv	Q39a_dic	Nominal	dic.	0,184	MODERATE RELATION	3,39%
Workload & workpace	Q40_inv	Q39d_dic	Nominal	dic.	0,177	MODERATE RELATION	3,13%
Workload & workpace	Q40_inv	Q39e_dic	Nominal	dic.	0,175	MODERATE RELATION	3,06%
Workload & workpace	Q40_inv	Q26_cat	Ordinal		0,169	MODERATE RELATION	2,86%
Workload & workpace	Q40_inv	Country	Nominal		0,149	MODERATE RELATION	2,22%
Workload & workpace	Q40_inv	Q24_cat	Ordinal		0,146	MODERATE RELATION	2,13%

Tabla 9 (continuación)

ASSOCIATIONS BETWEEN QUALITATIVE CONTROL/SEGMENTATION VARIABLES AND SCALE VARIABLES

GROUP	Variables				ETA value	Comments	Explained Variance
	Dependent	Independent	Measure	Type			
Workload & workpace	Q46_inv	Q37d_dic	Nominal	dic.	0,317	STRONG RELATION	10,05%
Workload & workpace	Q46_inv	Q39a_dic	Nominal	dic.	0,278	STRONG RELATION	7,73%
Workload & workpace	Q46_inv	Q39d_dic	Nominal	dic.	0,247	MODERATE RELATION	6,10%
Workload & workpace	Q46_inv	Q39c_dic	Nominal	dic.	0,227	MODERATE RELATION	5,15%
Workload & workpace	Q46_inv	Q38_dic_inv	Nominal	dic.	0,209	MODERATE RELATION	4,37%
Workload & workpace	Q46_inv	Country	Nominal		0,177	MODERATE RELATION	3,13%
Workload & workpace	Q46_inv	Q24_cat	Ordinal		0,166	MODERATE RELATION	2,76%
Workload & workpace	Q46_inv	Q37b_dic	Nominal	dic.	0,128	Small relation	1,64%
Workload & workpace	Q46_inv	Q14_a	Nominal	dic.	0,101	Small relation	1,02%

Tabla 11. Test de efectos indirectos de mediación

DESCRIPTIVE TABLE FOR MEDIATION STUDY			
DIRECT EFFECT 01_G-Home_Work	01_G-Home_Work → 12_Negative_Outcomes	INDIRECT EFFECT 01_G-Home_Work	01_G-Home_Work → 11_Positive_Outcomes → 12_Negative_Outcomes
C ₁ = C ₁ + a ₀₁ x b		Hypothesis 2	Hmed1 a ₀₁ x b
TOTAL EFFECT (C ₀₁)	C ₁ = C ₁ + a ₀₁ x b		
MEDIATION HYPOTHESIS	Hypothesis 1 n.a.		
C ₁			
DIRECT EFFECT 02_G-Envir_Eq	02_G-Envir_Eq → 12_Negative_Outcomes	INDIRECT EFFECT 02_G-Envir_Eq	02_G-Envir_Eq → 11_Positive_Outcomes → 12_Negative_Outcomes
C ₂ = C ₂ + a ₀₂ x b		Hypothesis 4	Hmed2 a ₀₂ x b
TOTAL EFFECT (C ₀₂)	C ₂ = C ₂ + a ₀₂ x b		
MEDIATION HYPOTHESIS	Hypothesis 3 n.a.		
C ₂			
DIRECT EFFECT 03_RiskAware_07G-Envir_Eq	03_RiskAware_07G-Envir_Eq → 12_Negative_Outcomes	INDIRECT EFFECT 03_RiskAware_07G-Envir_Eq	03_RiskAware_07G-Envir_Eq → 11_Positive_Outcomes → 12_Negative_Outcomes
C ₃ = C ₃ + a ₀₃ x b		Hypothesis 6	Hmed3 a ₀₃ x b
TOTAL EFFECT (C ₀₃)	C ₃ = C ₃ + a ₀₃ x b		
MEDIATION HYPOTHESIS	Hypothesis 5 n.a.		
C ₃			
DIRECT EFFECT 04_Workload_pace_08G-Worload_pace	04_Workload_pace_08G-Worload_pace → 12_Negative_Outcomes	INDIRECT EFFECT 04_Workload_pace_08G-Worload_pace	04_Workload_pace_08G-Worload_pace → 11_Positive_Outcomes → 12_Negative_Outcomes
C ₄ = C ₄ + a ₀₄ x b		Hypothesis 8	Hmed4 a ₀₄ x b
TOTAL EFFECT (C ₀₄)	C ₄ = C ₄ + a ₀₄ x b		
MEDIATION HYPOTHESIS	Hypothesis 7 n.a.		
C ₄			
DIRECT EFFECT 05_Ddlines_WPace_10G-Job_Content	05_Ddlines_WPace_10G-Job_Content → 12_Negative_Outcomes	INDIRECT EFFECT 05_Ddlines_WPace_10G-Job_Content	05_Ddlines_WPace_10G-Job_Content → 11_Positive_Outcomes → 12_Negative_Outcomes
C ₅ = C ₅ + a ₀₅ x b		Hypothesis 10	Hmed5 a ₀₅ x b
TOTAL EFFECT (C ₀₅)	C ₅ = C ₅ + a ₀₅ x b		
MEDIATION HYPOTHESIS	Hypothesis 9 n.a.		
C ₅			
DIRECT EFFECT 06_WMmeaning_11G-Job_Content	06_WMmeaning_11G-Job_Content → 12_Negative_Outcomes	INDIRECT EFFECT 06_WMmeaning_11G-Job_Content	06_WMmeaning_11G-Job_Content → 11_Positive_Outcomes → 12_Negative_Outcomes
C ₆ = C ₆ + a ₀₆ x b		Hypothesis 12	Hmed6 a ₀₆ x b
TOTAL EFFECT (C ₀₆)	C ₆ = C ₆ + a ₀₆ x b		
MEDIATION HYPOTHESIS	Hypothesis 11 n.a.		
C ₆			
DIRECT EFFECT 07_WorkCond_09G-Control	07_WorkCond_09G-Control → 12_Negative_Outcomes	INDIRECT EFFECT 07_WorkCond_09G-Control	07_WorkCond_09G-Control → 11_Positive_Outcomes → 12_Negative_Outcomes
C ₇ = C ₇ + a ₀₇ x b		Hypothesis 14	Hmed7 a ₀₇ x b
TOTAL EFFECT (C ₀₇)	C ₇ = C ₇ + a ₀₇ x b		
MEDIATION HYPOTHESIS	Hypothesis 13 n.a.		
C ₇			
DIRECT EFFECT 08_Org_relations_12G-Org_Culture	08_Org_relations_12G-Org_Culture → 12_Negative_Outcomes	INDIRECT EFFECT 08_Org_relations_12G-Org_Culture	08_Org_relations_12G-Org_Culture → 11_Positive_Outcomes → 12_Negative_Outcomes
C ₈ = C ₈ + a ₀₈ x b		Hypothesis 16	Hmed8 a ₀₈ x b
TOTAL EFFECT (C ₀₈)	C ₈ = C ₈ + a ₀₈ x b		
MEDIATION HYPOTHESIS	Hypothesis 15 n.a.		
C ₈			
DIRECT EFFECT 09_ChiefRelations_13G-WKRelations	09_ChiefRelations_13G-WKRelations → 12_Negative_Outcomes	INDIRECT EFFECT 09_ChiefRelations_13G-WKRelations	09_ChiefRelations_13G-WKRelations → 11_Positive_Outcomes → 12_Negative_Outcomes
C ₉ = C ₉ + a ₀₉ x b		Hypothesis 18	Hmed9 a ₀₉ x b
TOTAL EFFECT (C ₀₉)	C ₉ = C ₉ + a ₀₉ x b		
MEDIATION HYPOTHESIS	Hypothesis 17 n.a.		
C ₉			
DIRECT EFFECT 10_Present_sit_14_G-Career_dvlop	10_Present_sit_14_G-Career_dvlop → 12_Negative_Outcomes	INDIRECT EFFECT 10_Present_sit_14_G-Career_dvlop	10_Present_sit_14_G-Career_dvlop → 11_Positive_Outcomes → 12_Negative_Outcomes
C ₁₀ = C ₁₀ + a ₁₀ x b		Hypothesis 20	Hmed10 a ₁₀ x b
TOTAL EFFECT (C ₁₀)	C ₁₀ = C ₁₀ + a ₁₀ x b		
MEDIATION HYPOTHESIS	Hypothesis 19 n.a.		
C ₁₀			

Tabla 12. Tabla Resumen de datos a considerar para el modelo V01A

CONSTRUCTS	Composite specification		Components		Measurement Variables								
	Simplified	Mode A	Mode B	Level	Simplified		Simplified		Scale				
	Mention				Mention	Weights	Mention	Loads	Min	Max	Direct	Invert	Factor
01_G-Home_Work	01HW	Y	2	01_Changes_12M_G-Home_Work	01CHHW	0,222	Q18ai	0,759	1	5	yes		5+1 - reading value
							Q18ci	0,610	1	5	yes		5+1 - reading value
							Q18di	0,869	1	5	yes		5+1 - reading value
							Q44_rect	0,905	1	4	yes		
							Q47_rect	0,664	1	4	yes		
02_G-Envir_Eq	02EE	Y	2	03_Risk_expo1_G-Envir_Eq	03RKEE	0,460	Q29a_inv_ReplaceMD_1	0,723	1	7	yes		7+1 - reading value
							Q29b_inv_ReplaceMD_1	0,779	1	7	yes		7+1 - reading value
							Q29c_inv_ReplaceMD_1	0,777	1	7	yes		7+1 - reading value
							Q29d_inv_ReplaceMD_1	0,715	1	7	yes		7+1 - reading value
							Q29e_inv_ReplaceMD_1	0,724	1	7	yes		7+1 - reading value
							Q29f_inv_LD	0,797	1	7	yes		7+1 - reading value
							Q29g_inv_LD	0,853	1	7	yes		7+1 - reading value
							Q29i	0,757	1	7	yes		7+1 - reading value
							Q29ii	0,757	1	7	yes		7+1 - reading value
							Q30f_inv_ReplaceMD_1	0,554	1	7	yes		7+1 - reading value
							Q30g_inv_ReplaceMD_1	0,784	1	7	yes		7+1 - reading value
							Q30h_inv_ReplaceMD_1	0,898	1	7	yes		7+1 - reading value
							Q30d_inv_LD	0,793	1	7	yes		7+1 - reading value
							Q30i_inv_ReplaceMD_1	0,954	1	7	yes		7+1 - reading value
03_RiskAware_07G-Envir_Eq	03RiskEE	Y	1	05_Task_efforts1_G-Envir_Eq	05TEEE	0,785	Q33i	0,565	1	4	yes		4+1 - reading value
							Q61a_inv	0,766	1	5	yes		5+1 - reading value
							Q61b_inv	0,847	1	5	yes		5+1 - reading value
							Q46_inv	0,816	1	5	yes		5+1 - reading value
							Q51_inv	0,756	1	4	yes		4+1 - reading value
04_Workload_pace_08G-Workload_pace	04WPWP	Y	1				Q49a_inv	0,906	1	7	yes		7+1 - reading value
							Q49b_inv	0,909	1	7	yes		7+1 - reading value
							Q61h_inv	0,814	1	5	yes		5+1 - reading value
							Q61j_inv	0,773	1	5	yes		5+1 - reading value
							Q61k_inv	0,616	1	5	yes		5+1 - reading value
							Q61l_inv	0,760	1	5	yes		5+1 - reading value
							Q61c_inv	0,738	1	5	yes		5+1 - reading value
07_WorkCond_09G-Control	07WCC	Y	1				Q61d_inv	0,765	1	5	yes		5+1 - reading value
							Q61e_inv	0,603	1	5	yes		5+1 - reading value
							Q61f_inv	0,510	1	5	yes		5+1 - reading value
							Q61i_inv	0,781	1	5	yes		5+1 - reading value
							Q61n_inv	0,808	1	5	yes		5+1 - reading value

Tabla 12. (continuación)

CONSTRUCTS	Composite specification			Components		Measurement Variables					
	Simplified Mention	Mode A	Mode B Level	Simplified Mention	Weights	Simplified Mention	Loads	Min	Max	Scale	
		Y								Direct Invert	Factor
08_Org_relations_12G-Org_Culture	08OROC	Y	1			Q70a_inv	0,757	1	5	yes	5+1 - reading value
						Q70b_inv	0,740	1	5	yes	5+1 - reading value
						Q70c_inv	0,785	1	5	yes	5+1 - reading value
						Q70d_inv	0,740	1	5	yes	5+1 - reading value
						Q70e_inv	0,652	1	5	yes	5+1 - reading value
						Q70f_inv	0,783	1	5	yes	5+1 - reading value
						Q89d_inv	0,537	1	5	yes	5+1 - reading value
						Q89e_inv	0,708	1	5	yes	5+1 - reading value
10_Present_sit_14_G-Career_dvelop	105ITCD	Y	1			Q89a_inv	0,807	1	5	yes	5+1 - reading value
						Q89b_inv	0,713	1	5	yes	5+1 - reading value
						Q89c_inv	0,867	1	5	yes	5+1 - reading value
11_Positive_Outcomes	11PO	Y	2	15_Satisfaction_G-Results_Effects	0,680	Q88_inv	0,745	1	4	yes	4+1 - reading value
						Q90a_inv	0,798	1	5	yes	5+1 - reading value
						Q90b_inv	0,814	1	5	yes	5+1 - reading value
						Q90c_inv	0,614	1	5	yes	5+1 - reading value
				16_Mind_welfare_G-Results_Effects	0,453	Q87a_inv	0,838	1	6	yes	6+1 - reading value
						Q87b_inv	0,844	1	6	yes	6+1 - reading value
						Q87c_inv	0,853	1	6	yes	6+1 - reading value
						Q87d_inv	0,835	1	6	yes	6+1 - reading value
						Q87e_inv	0,741	1	6	yes	6+1 - reading value
12_Negative_Outcomes	12NO	Y	2	17_Sleep_disorders_G-Results_Effects	0,510	Q61m_inv	0,595	1	5	yes	5+1 - reading value
						Q79a_inv	0,778	1	5	yes	5+1 - reading value
						Q79b_inv	0,779	1	5	yes	5+1 - reading value
						Q79c_inv	0,827	1	5	yes	5+1 - reading value
				18_Work_effects1_G-Results_Effects	0,653	Q45a_inv	0,656	1	5	yes	5+1 - reading value
						Q45b_inv	0,714	1	5	yes	5+1 - reading value
						Q45c_inv	0,812	1	5	yes	5+1 - reading value
						Q45d_inv	0,719	1	5	yes	5+1 - reading value
						Q45e_inv	0,679	1	5	yes	5+1 - reading value